

ISOMETRIC VIEWS

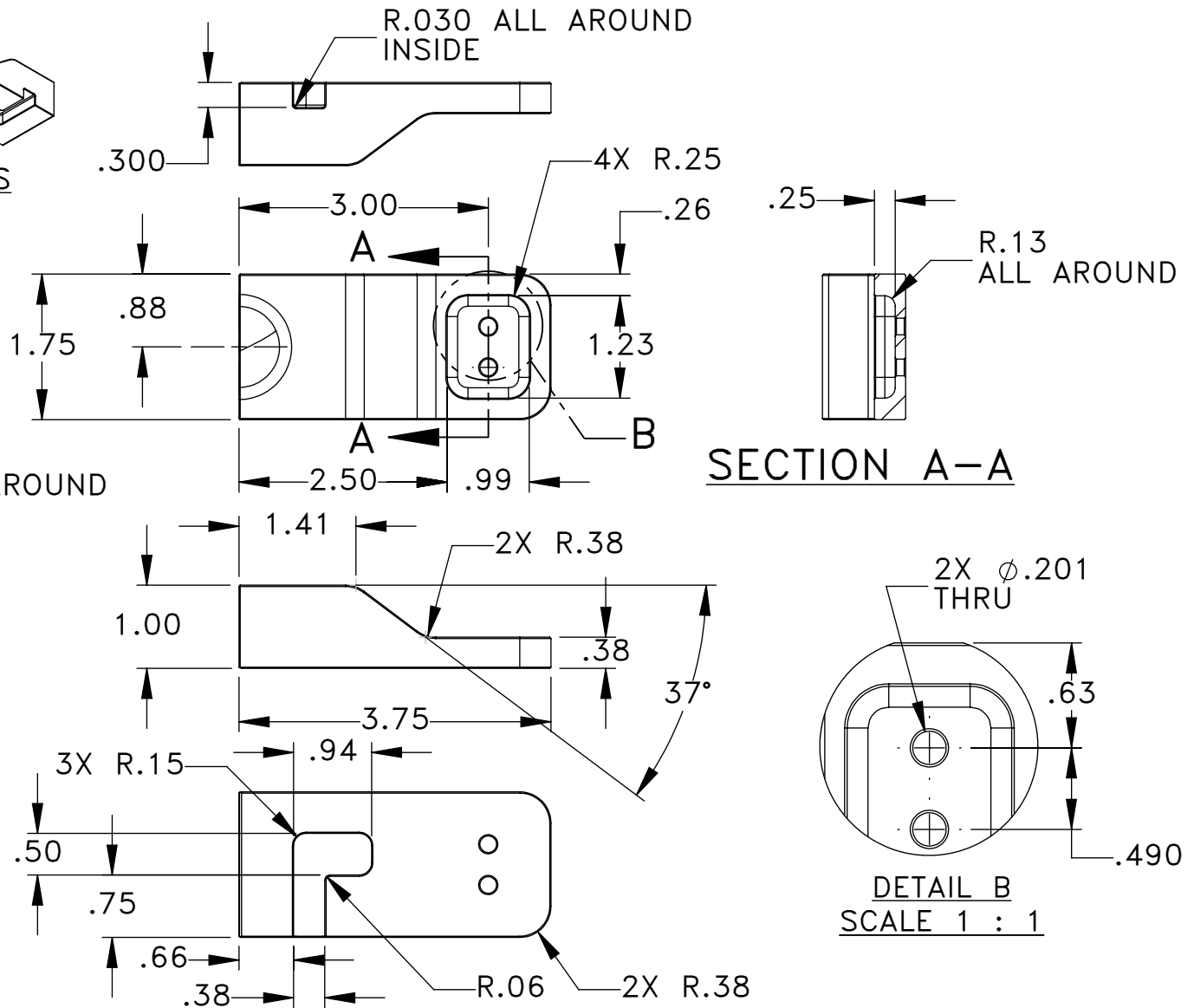

DIMS IN INCHES BREAK EDGES 0.015
 LATHE FINISH 63 μINCH MILL FINISH 125 μINCH
 90° CSINK TAPPED HOLES 0.016R OVER MAJOR Ø
 TOLERANCES- UNLESS OTHERWISE SPECIFIED
 X/X ±0.06 X.X ±0.06 X.XX ±0.02 X.XXX ±0.005
 ANGLES ±1° X.XXX DIAMETERS ⌀ 0.005 TIR
 X.XXXDIA & SURFACES // & | 0.001 INCH/INCH



HAAS AUTOMATION, INC.

ADVANCED LEVEL MILL

MATERIAL	FINISH	SIZE	SCALE	DWG	REV
6061-T6	NONE	A	1:2	AM-1	

A B C D E F G H J