

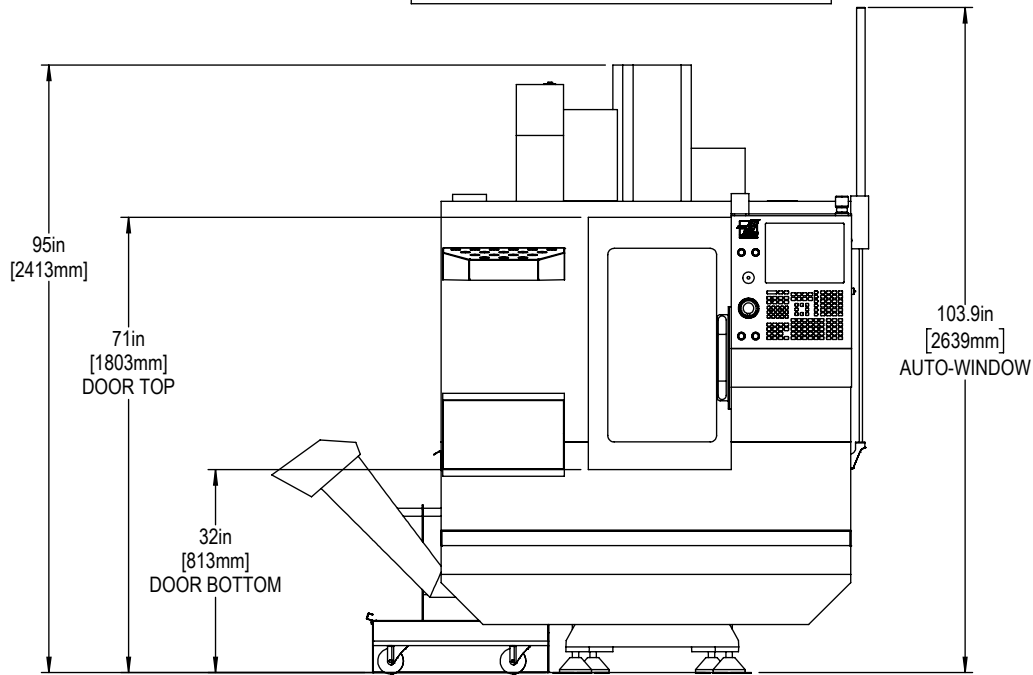

FRONT VIEW - OPERATIONAL HEIGHT



REFER TO THE INSTALLATION INSTRUCTIONS FOR STEP BY STEP GUIDANCE

TOP VIEW - OPERATIONAL DEPTH AND WIDTH

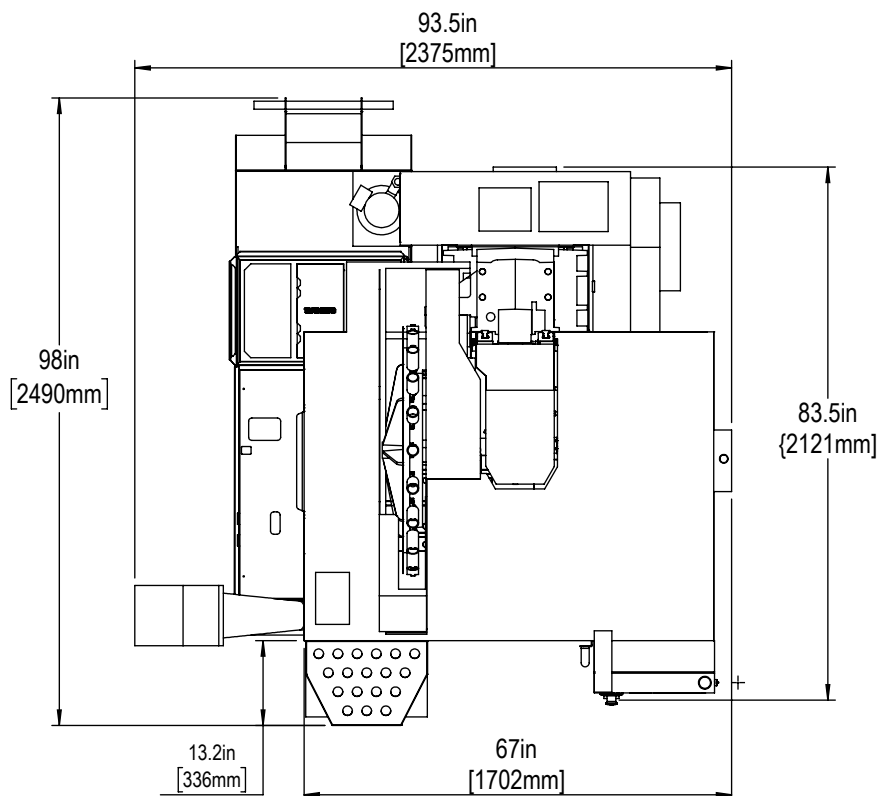



FRONT VIEW

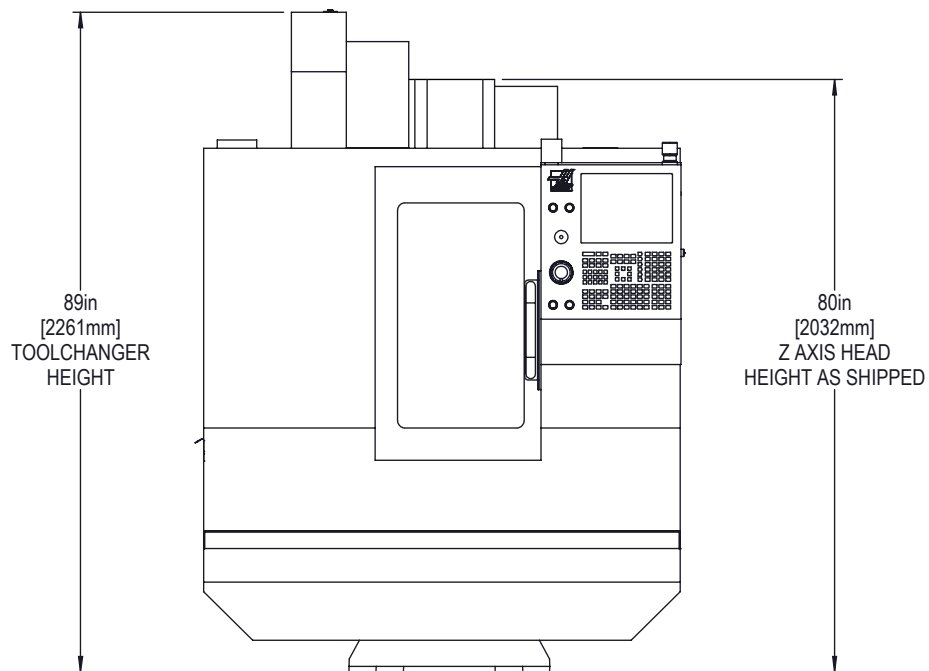

DIMENSIONS ARE FROM THE BOTTOM OF THE BASE

MACHINE SHOWN WITHOUT ANY LEVELING SCREWS, PADS AND SHIPPING MATERIALS

TOP VIEW

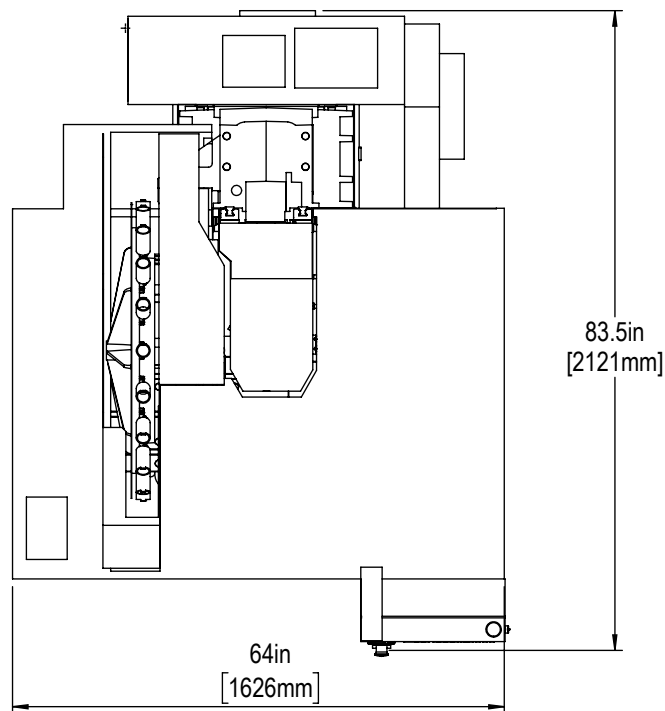
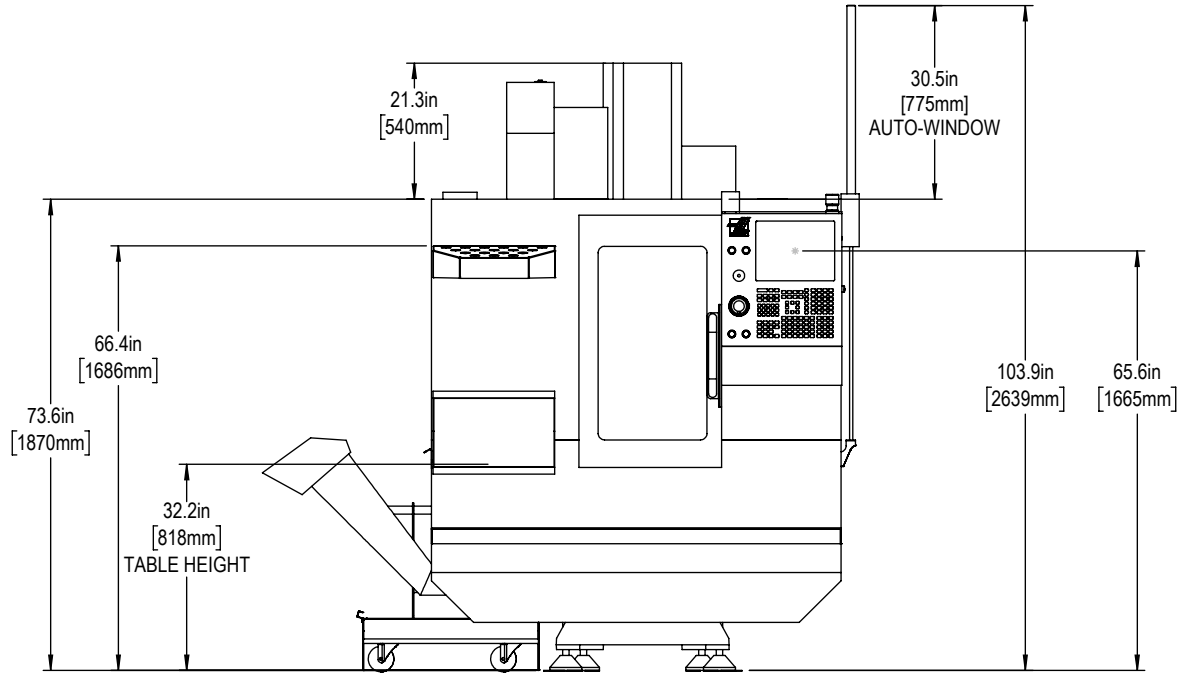

IMAGE SHOWN AS SHIPPED (NO COOLANT TANK) TO SHOW THE SMALLEST DEPTH



HEIGHT BREAKDOWNS



DEPTH AND WIDTH BREAKDOWNS

DRAWINGS NOT TO SCALE

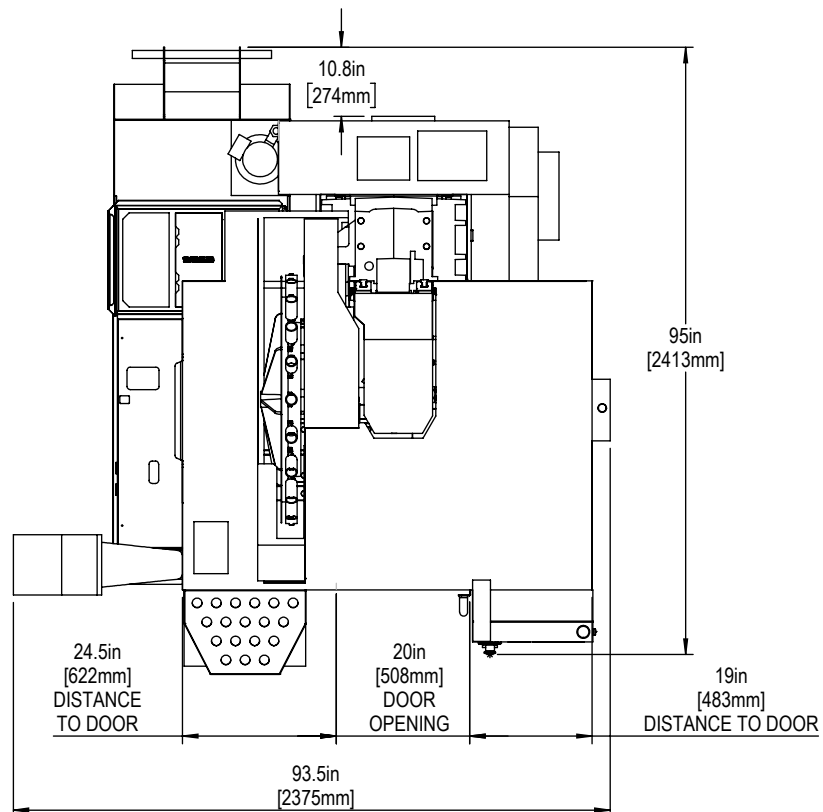



BACK VIEW

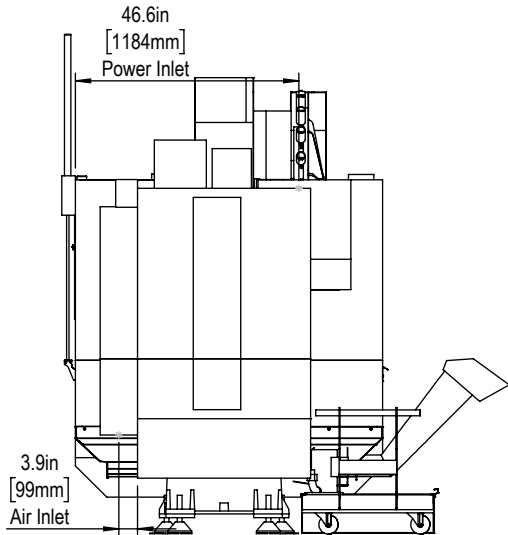

RIGHT SIDE VIEW

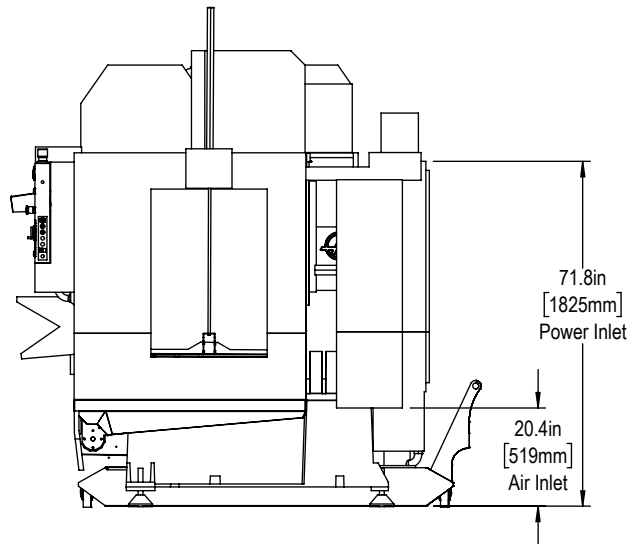

REFER TO MACHINE INSTALLATION INSTRUCTIONS FOR DETAILS

A 36in [914mm] CLEARANCE IS REQUIRED FOR ELECTRICAL CABINET

NOTE: MACHINE MUST BE PLACED ON ONE CONTINUOUS CONCRETE SLAB.
SLAB SHOULD EXTEND 12in [305mm] BEYOND ANCHOR HOLES IN ALL DIRECTIONS

ANCHOR HOLE
DETAILS:
Ø 0.62in [16mm]
▽ 2in [51mm]
▽ 2.25in [57mm]

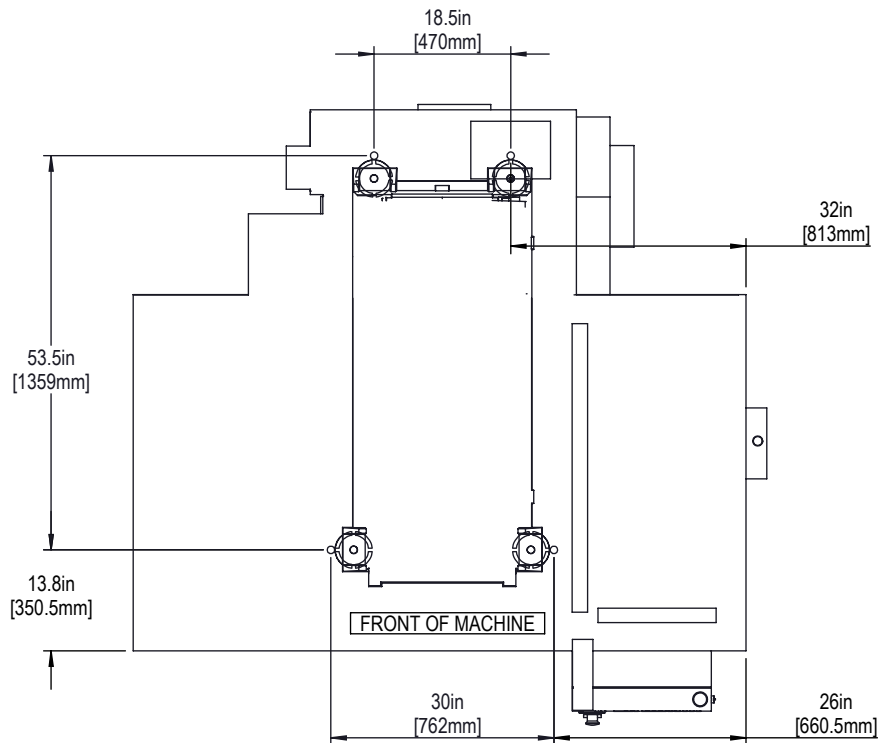

FOR PRECISE DRILLING LOCATIONS PLEASE USE THE TEMPLATE FROM THE MACHINE ANCHORING KIT

X AND Y AXIS TRAVELS

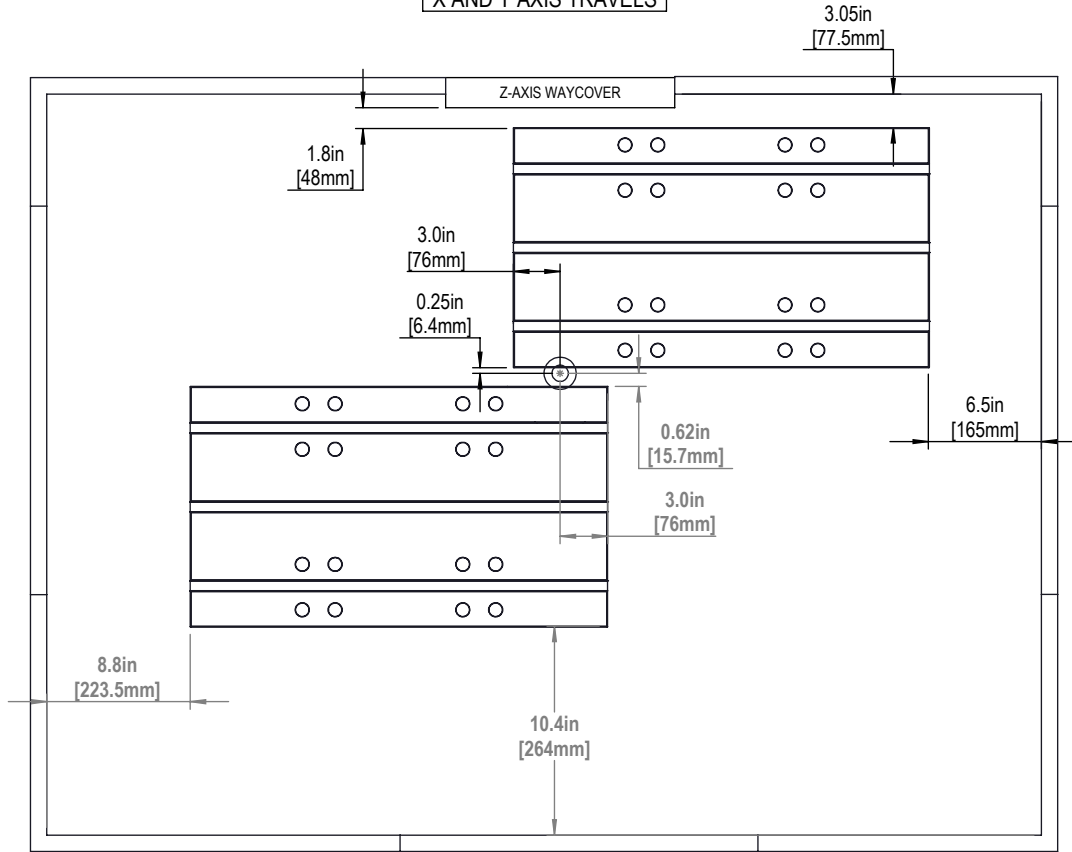

SKETCHES NOT TO SCALE

Z AXIS TRAVELS

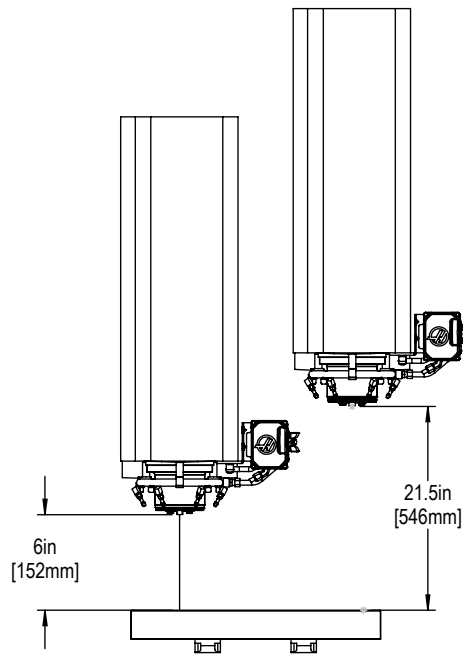

MACHINE TABLE FRONT VIEW

TABLE

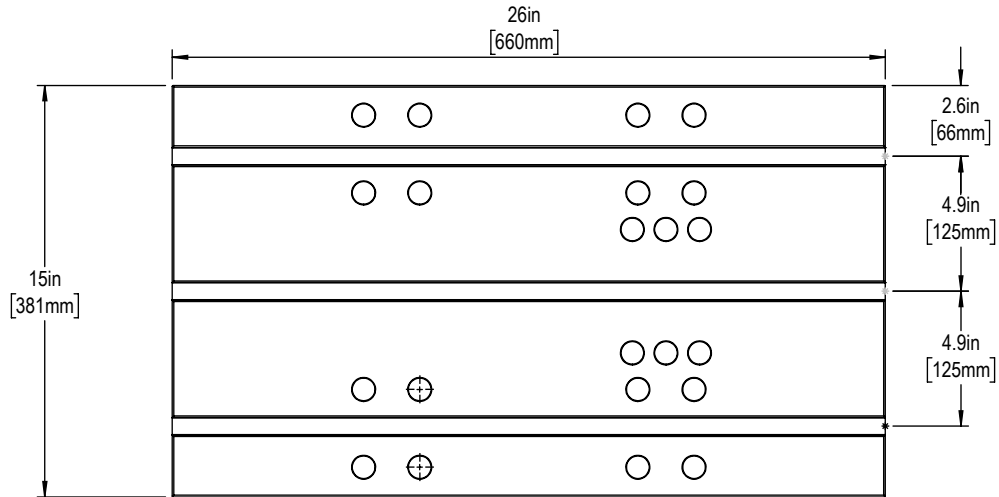

Slot Size	A	B	C	D
16mm	0.628in	1.06in	0.64in	0.42in
16mm	16mm	27mm	16mm	10.5mm

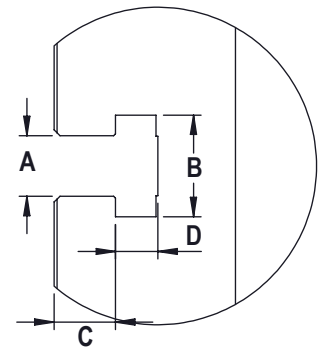

TOOL CHANGER

