

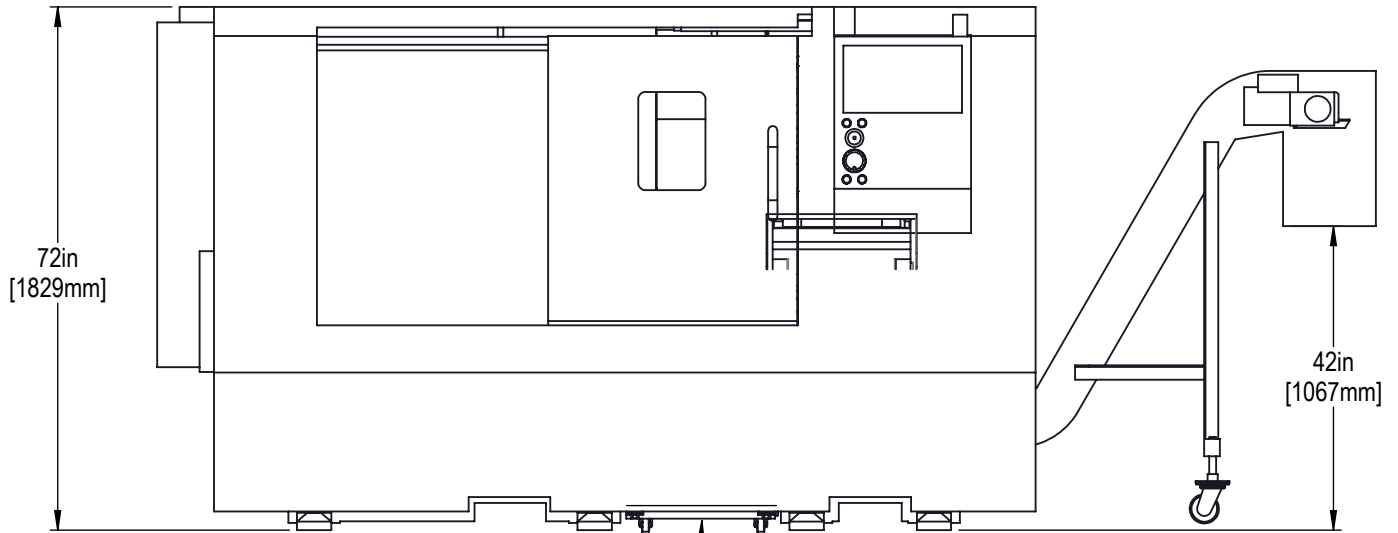

FRONT VIEW - OPERATIONAL HEIGHT DIMENSION



COOLANT TANK MAY ALSO BE REMOVED FROM THE FRONT
- ACCESS PANEL AND PUMP(S) REMOVAL REQUIRED -
(REMOVED PANEL SHOWN ABOVE)

DRAWING NOT TO SCALE

TOP VIEW - OPERATIONAL DEPTH AND WIDTH DIMENSIONS

54in (1372mm) CLEARANCE DISTANCE REQUIRED TO
REMOVE COOLANT TANK FROM THE REAR OF THE MACHINE

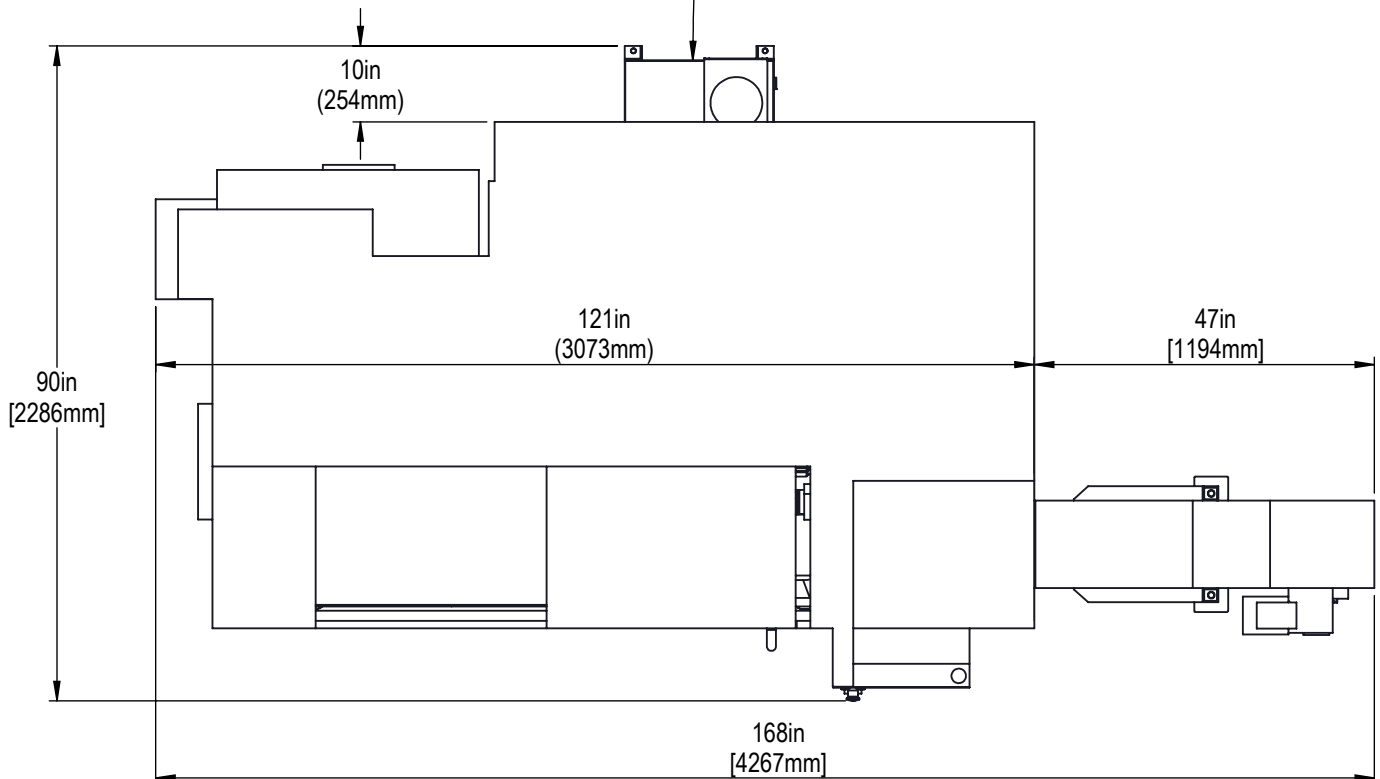

REFER TO THE INSTALLATION INSTRUCTIONS FOR STEP BY STEP GUIDANCE

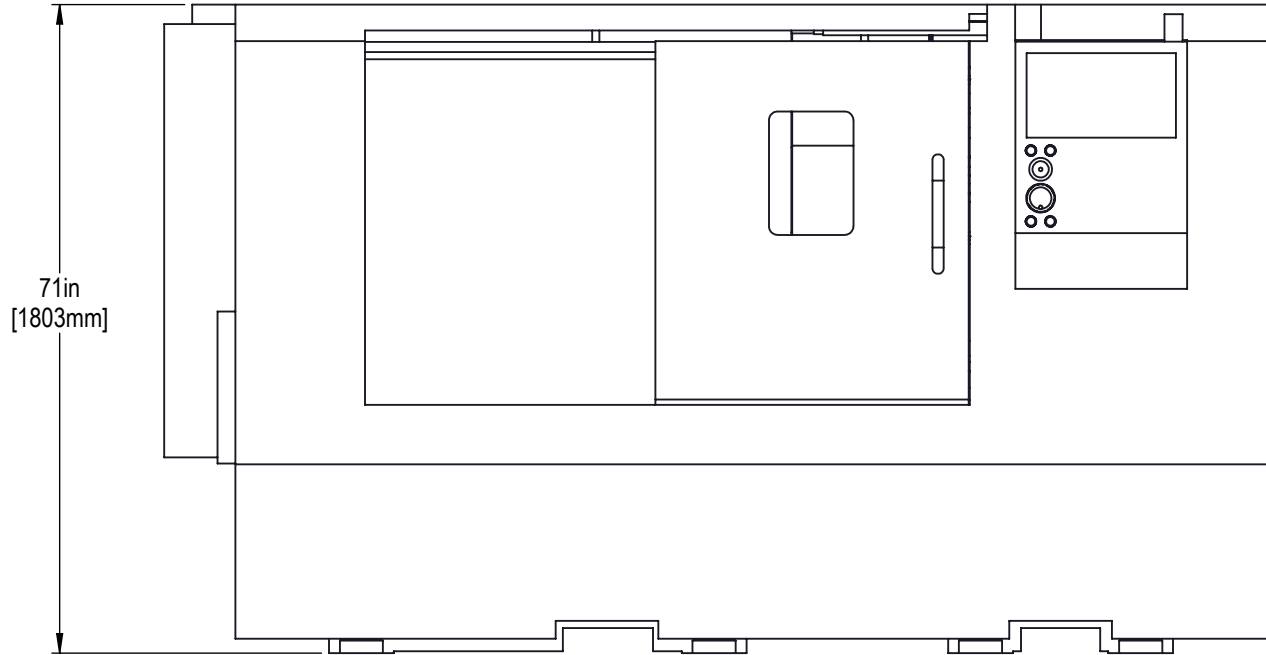

DIMENSIONS SHOWN FROM THE BOTTOM OF THE BASE TO THE HIGHEST POINT

LEVELING SCREWS AND PADS ARE REMOVED TO REDUCE HEIGHT

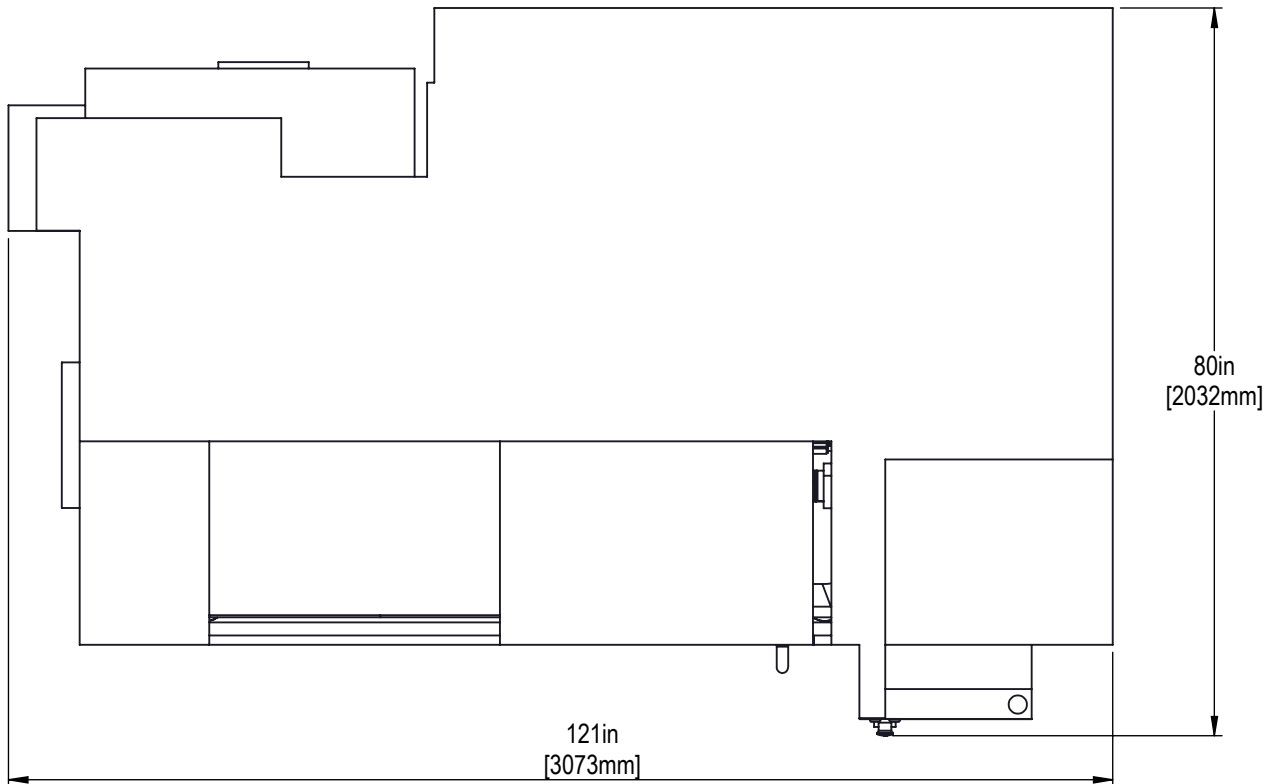

DIMENSIONS SHOWN WITH MACHINE OFF OF THE PALLET

OPTIONAL CONVEYOR SHIPS OFF OF THE MACHINE WHEN SELECTED

FRONT VIEW - HEIGHT DIMENSIONS

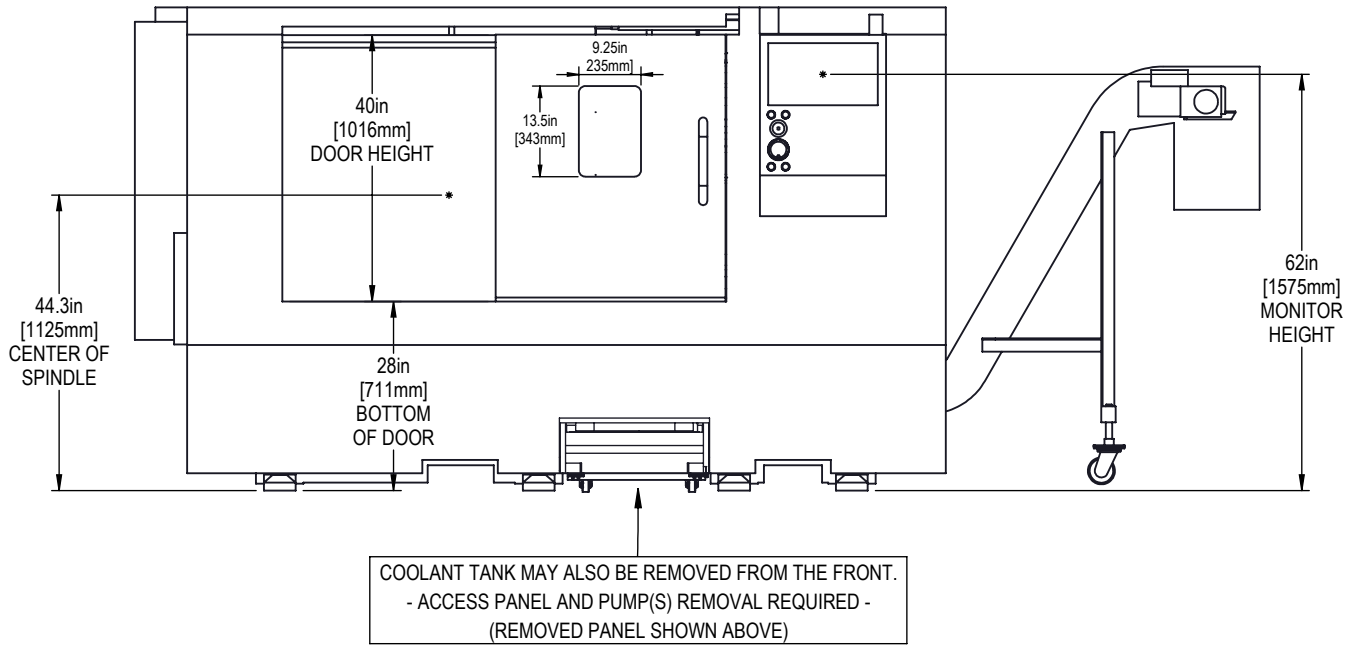

DRAWINGS NOT TO SCALE

TOP VIEW - DEPTH AND WIDTH DIMENSIONS

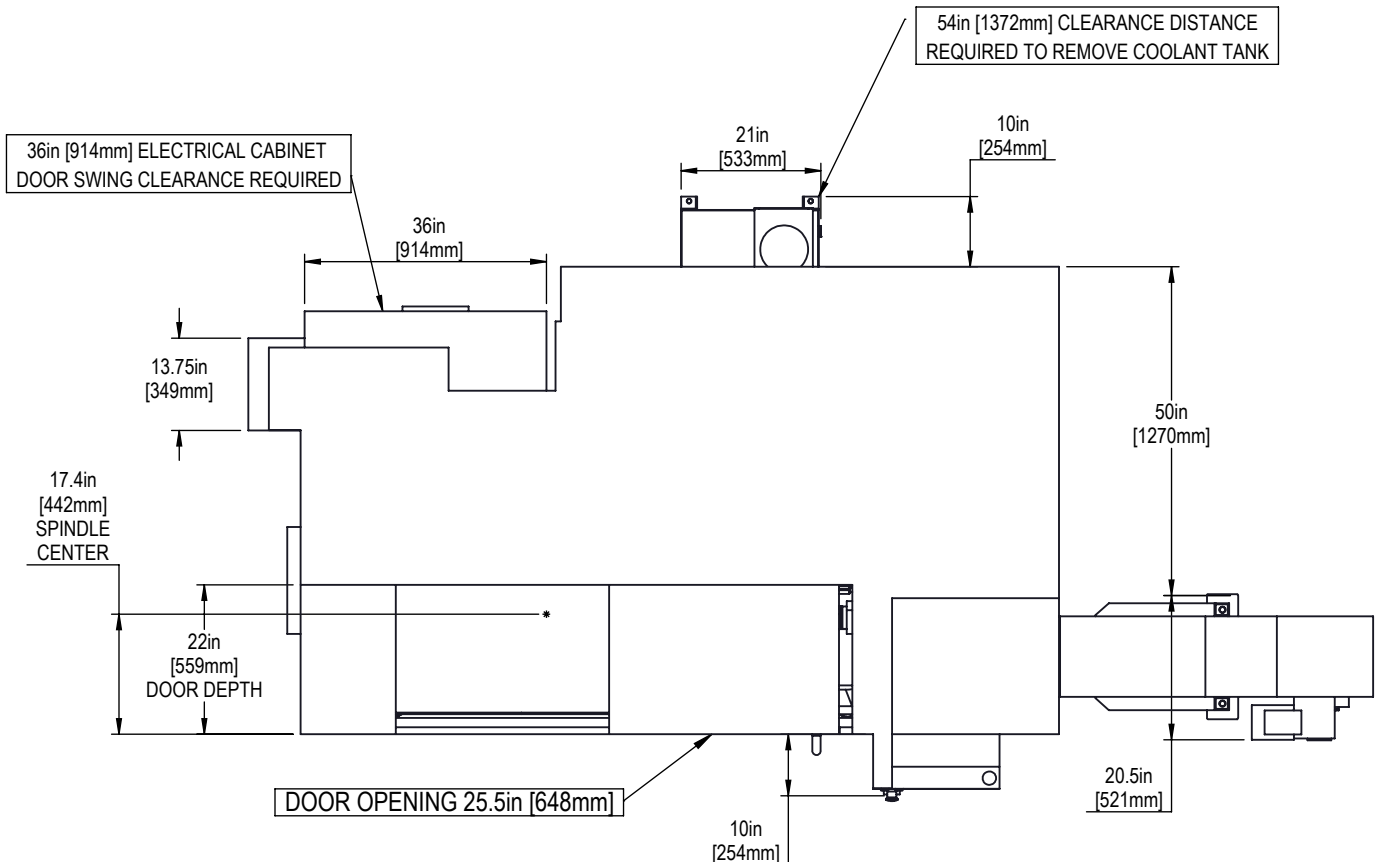



BACK VIEW

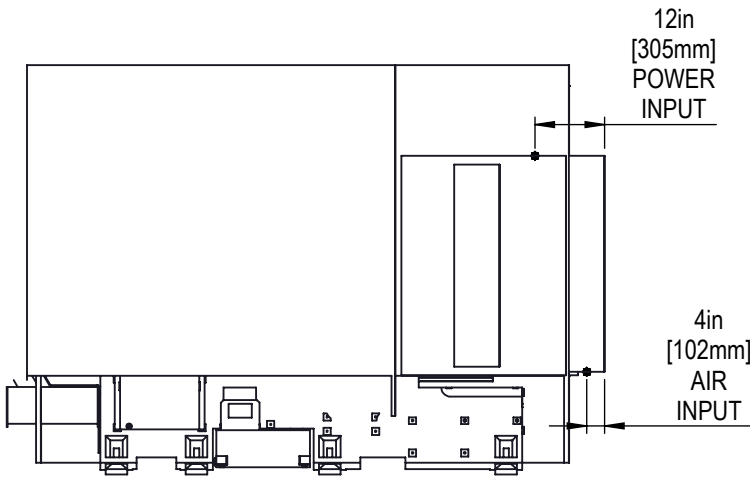

LEFT SIDE VIEW

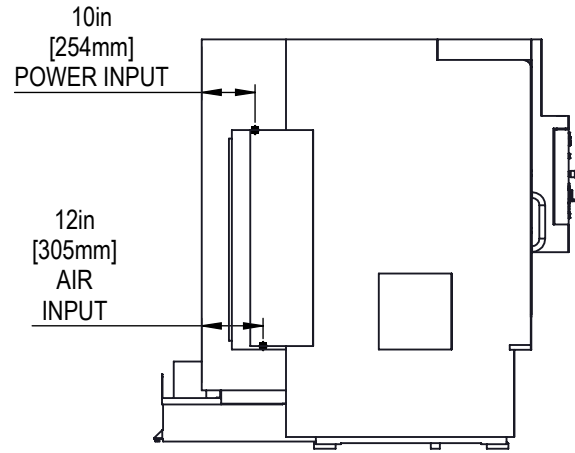

REFER TO MACHINE INSTALLATION INSTRUCTIONS FOR DETAILS

36in [914mm] CLEARANCE REQUIRED FOR ELECTRICAL CABINET DOOR SWING

MACHINE MUST BE PLACED ON A SINGLE CONTINUOUS CONCRETE SLAB. SLAB MUST EXTEND 12in [305mm] BEYOND LEVELING PAD LOCATIONS IN ALL DIRECTIONS

THERE IS NO CURRENT ANCHORING REQUIREMENT FOR THIS MACHINE

TOP VIEW

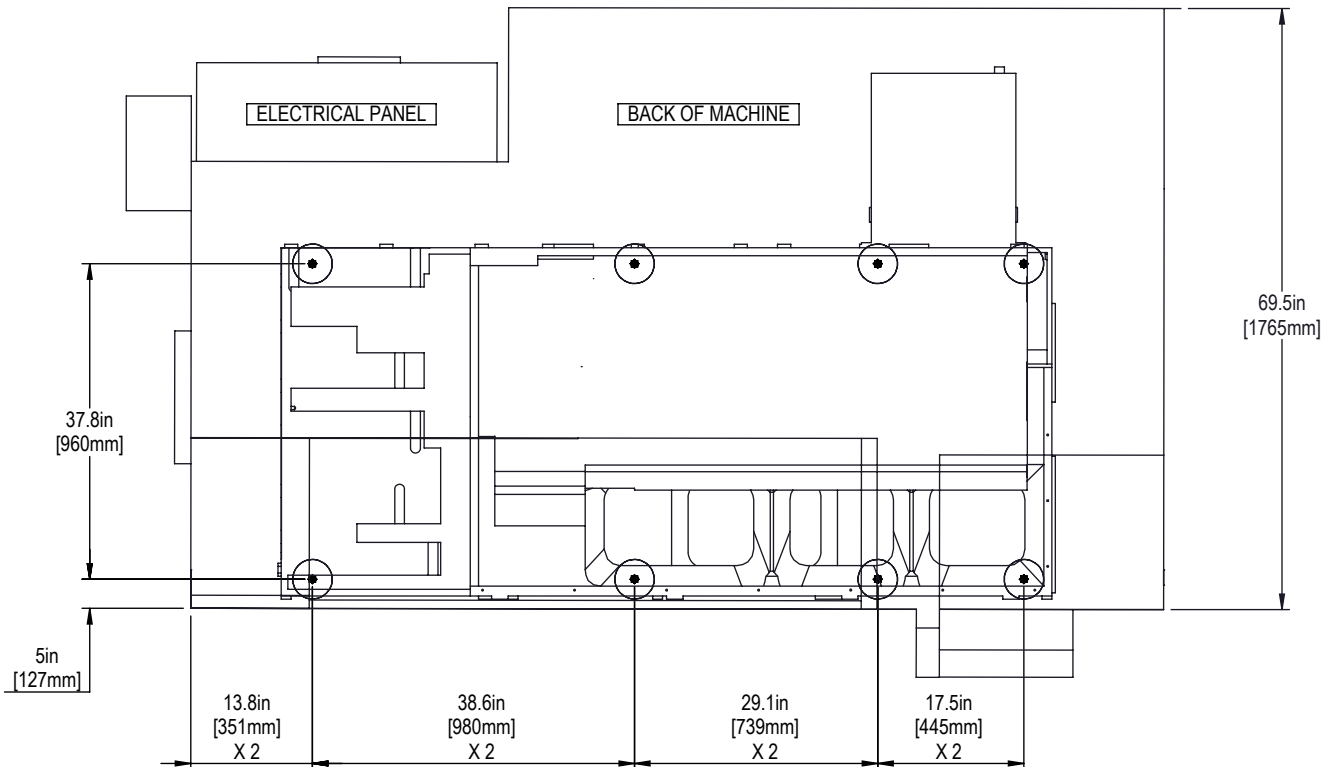

BMT65 OD TURNING

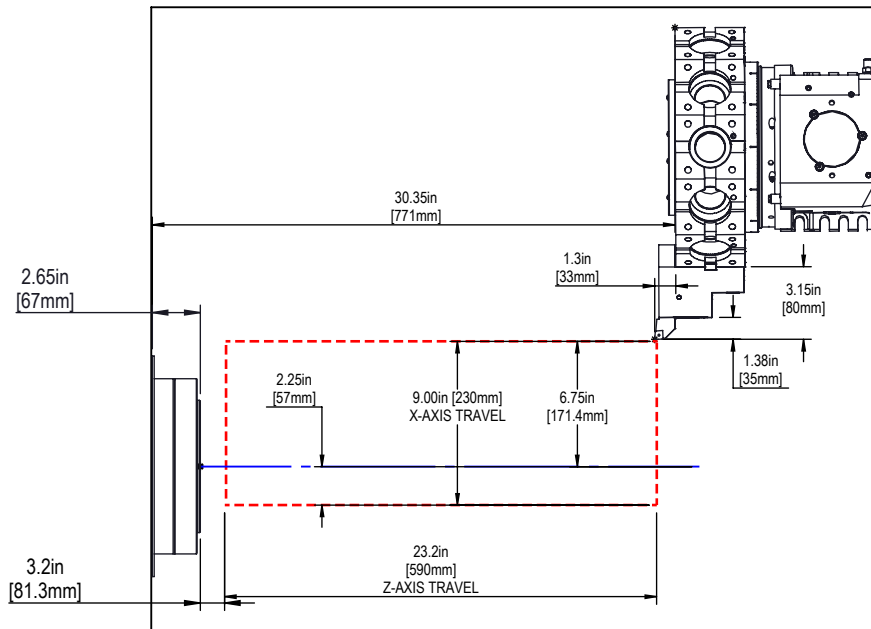

NOTE: DRAWINGS NOT TO SCALE

BMT65 ID TURNING

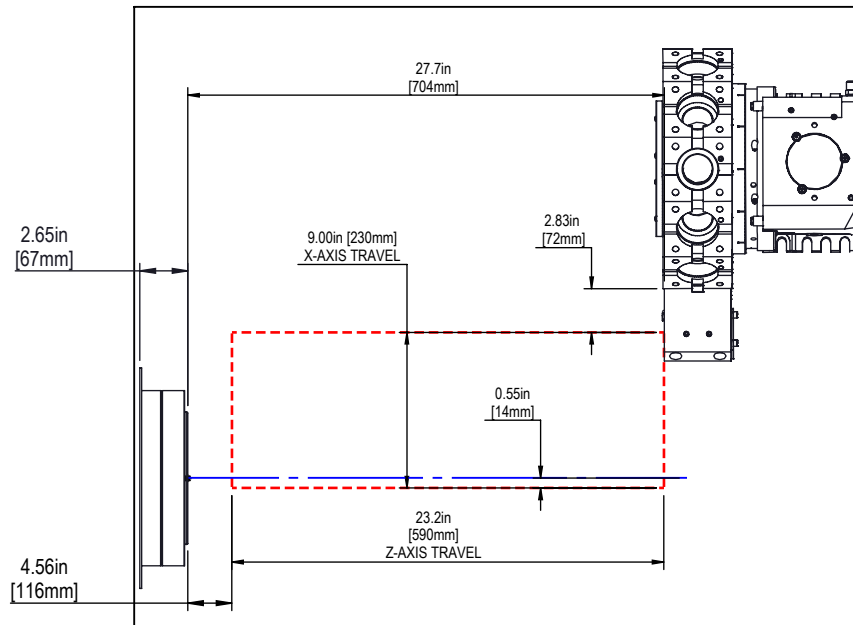

ALL Z-AXIS DIMENSIONS TO SPINDLE FACE

ALL X-AXIS DIMENSIONS ARE TO SPINDLE CENTER

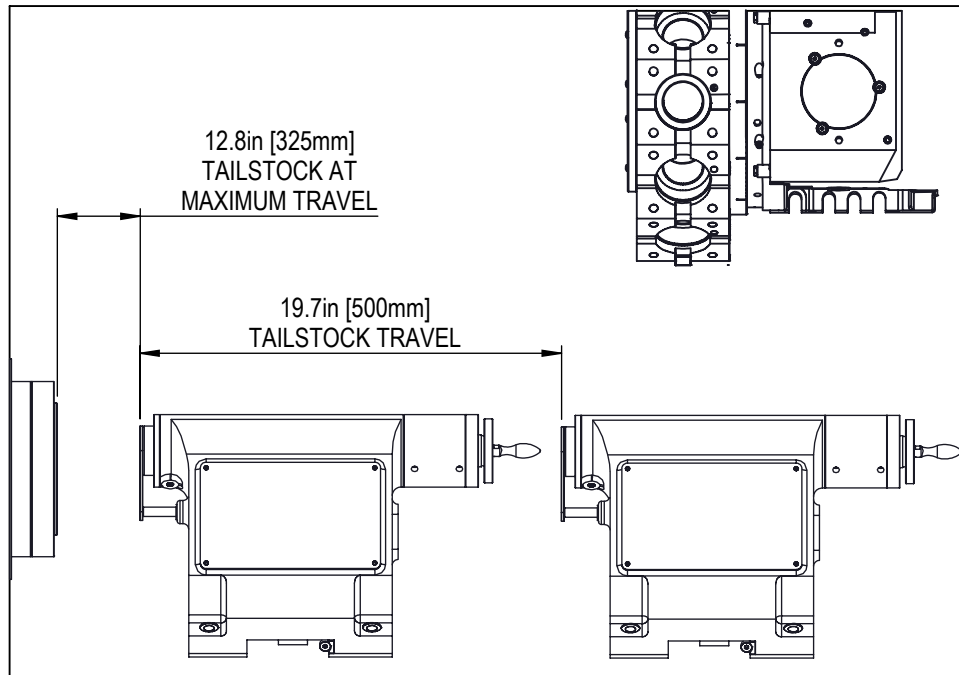

TAILSTOCK BODY IS TOWED AND POSITIONED BY THE Z-AXIS WEDGE

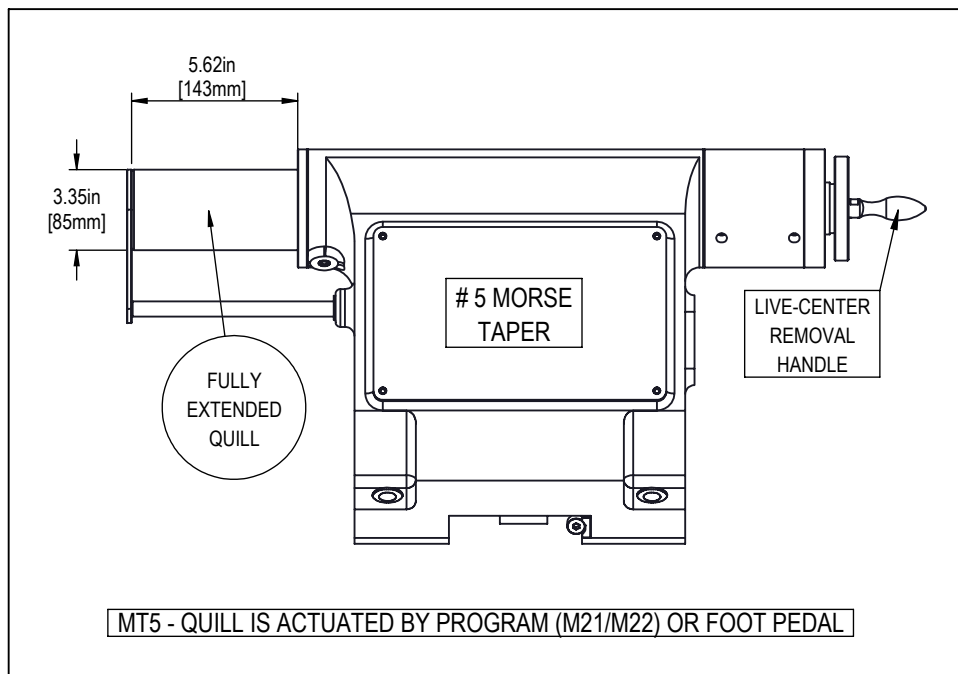

M321 (P) - TAILSTOCK ENGAGE AND POSITION

M322 - TAILSTOCK PARK OR HOME AND DISENGAGE

10in (254mm) STANDARD CHUCK

SIDE VIEW

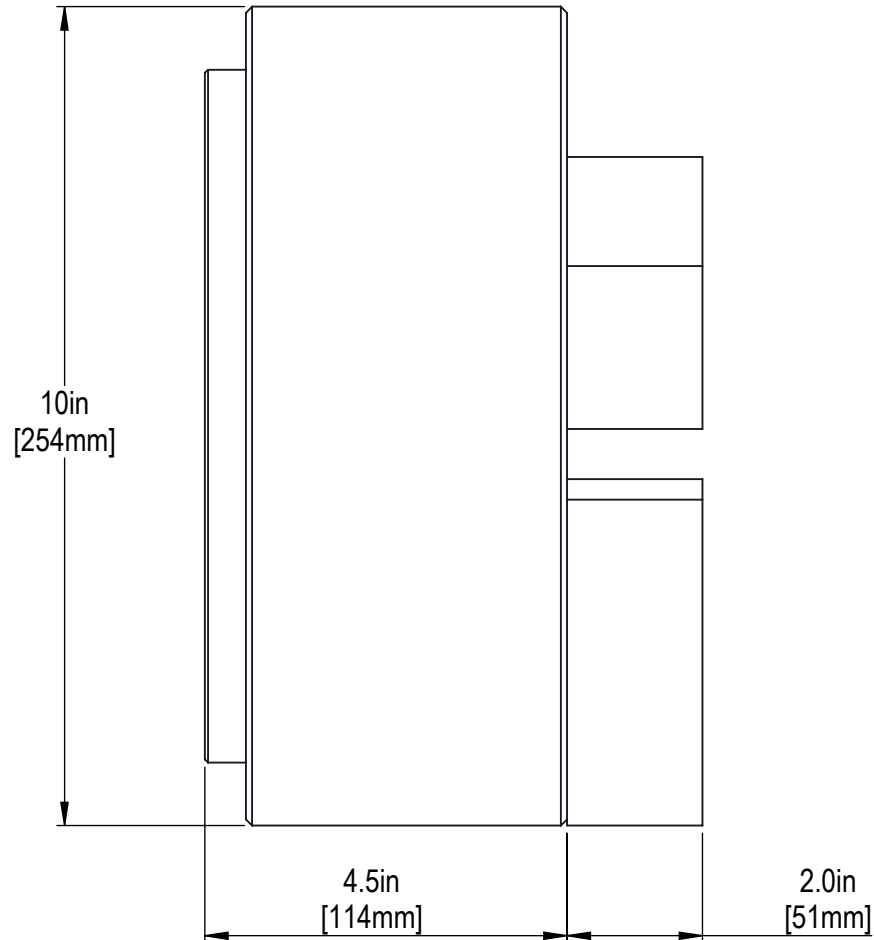

DESCRIPTION	
NOMINAL CHUCK DIAMETER	10in [254mm]
CHUCK BORE DIAMETER	3.00in [76mm]
NUT THREAD	M85 X 2.0
FACE TO DRAWTUBE EXTENDED	2.6in [66mm]
FACE TO DRAWTUBE RETRACTED	1.6in [41mm]
MASTER JAW SERRATIONS	1.5mm X 60°
MASTER JAW SCREW THREADS	0.47in [12mm]
MASTER JAW SCREW SPACING	1.18in [30mm]
MASTER JAW SLOT WIDTH	0.63in [16mm]
SPINDLE NOSE	A2-8
MAXIMUM SPEED	3200-rpm

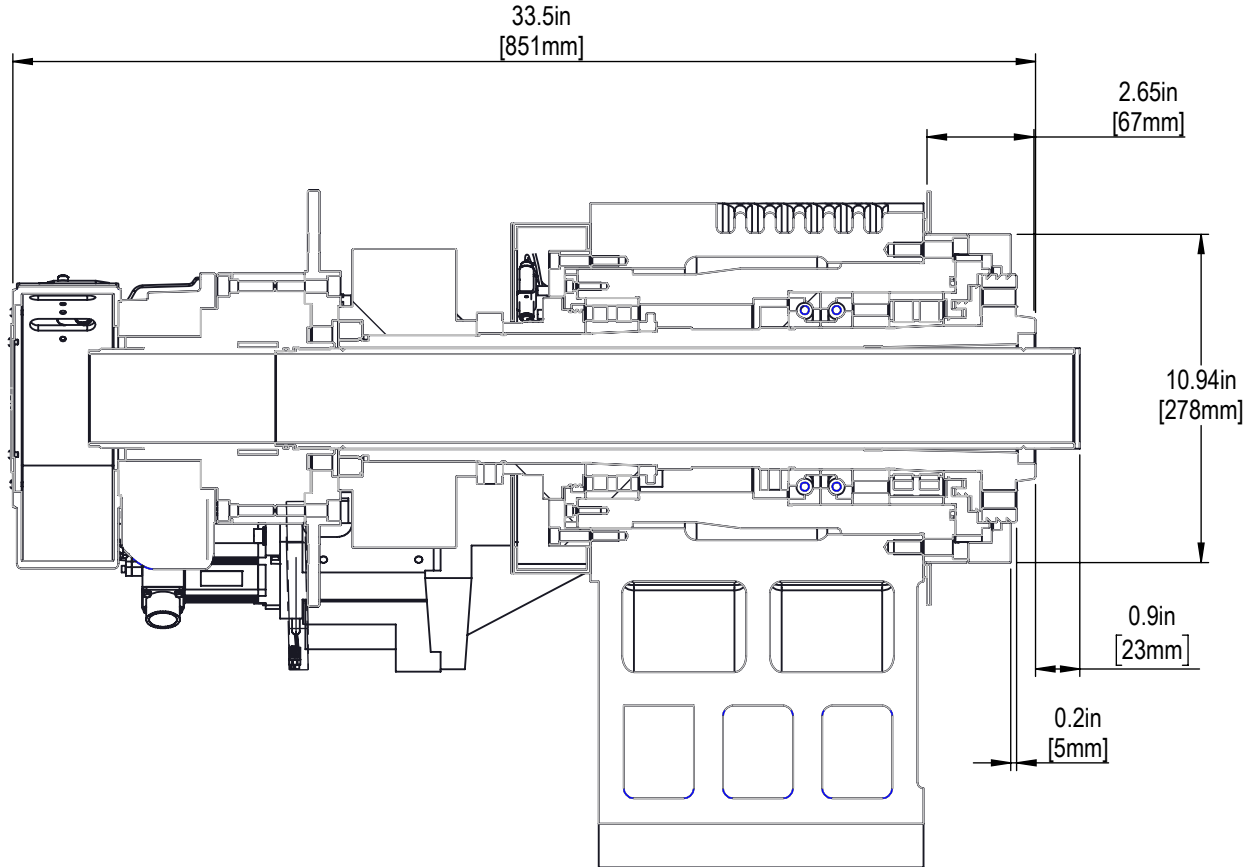

DESCRIPTION	
DRAWTUBE THREAD	M85 x 2.0
DRAWTUBE INTERNAL DIAMETER	2.9in [74 mm]
DRAWTUBE EXTENDED DISTANCE FROM FACE	2.6in [66mm]
DRAWTUBE RETRACTED DISTANCE FROM FACE	1.6in [41mm]
SPINDLE INTERNAL BORE DIAMETER	3.39in [86mm]
SPINDLE INTERNAL COUNTERBORE DIAMETER	4.33in [110mm]
SPINDLE INTERNAL COUNTERBORE DEPTH	0.59in [15mm]

HAAS AUTOMATION STRONGLY RECCOMENDS TAKING DIRECT MEASUREMENTS FROM THE MACHINE FOR THE PURPOSE OF USING 3RD-PARTY WORKHOLDING

Maximum Tool Length from
Turret Side (Periphery) to Waycover
Interference is 8in [203mm]

Maximum Tool Length from
Turret Side (Periphery) to Tailstock
Body is 10in [254mm]

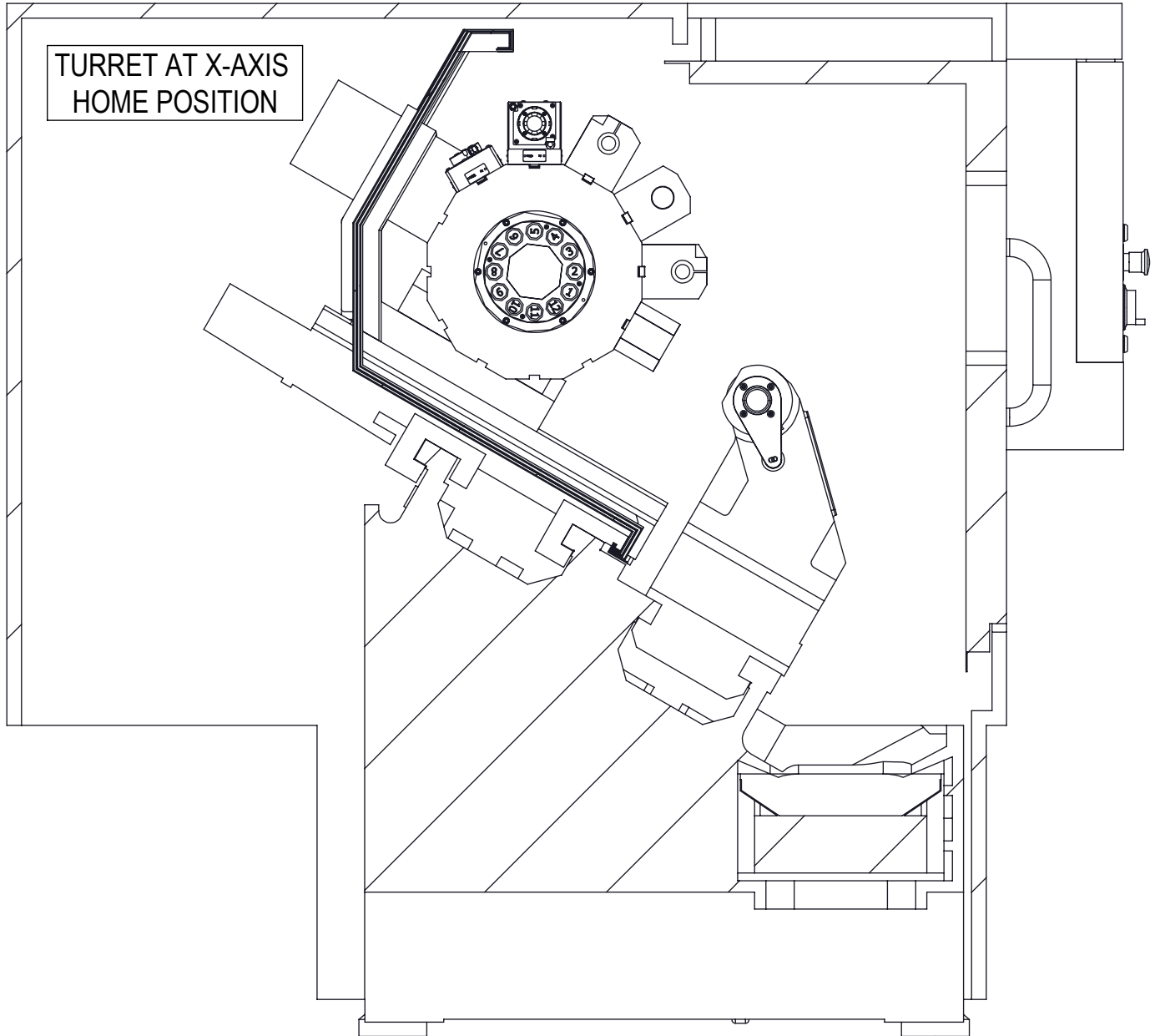

CLEARANCE BEHIND BMT65 TURRET IS 2in [51mm] FROM TURRET FACE