



HAAS AUTOMATION, INC  
**DEALER**  
**MEETING** 25

Haas Automation Europe

# Thank you!



- 2024 has been a tough year for the Global machine tool Industry.....
  - But despite this, we made huge progress toward reinventing Haas.
  - We developed over 20 new products in 2024.
  - We changed our strategy and the way we engineer, develop, and produce new machines.
  - We grew our ecommerce business to more than \$57 million in revenue.
  - We took market share and grew our business in Europe by over 20%.....great job!
  - And with a lot of teamwork, we grew 2024 revenue to exceed 2023's revenue.



# Today's Agenda



- 2024 Final Numbers
- Growth Strategy
  - Machine Tool NEW Product Development Strategy
    - Haas machine upgrades and improvements
    - 2024 New Product Summary
      - Products coming in 2025
      - Automation update
    - Why we want service parts back
- Update of Haas Tooling & the Ecommerce business
- F1 Update
- Henderson Update
- Final word on “Growing in Europe”

# 2024 Final Numbers

# 2024 Revenue



- 2024 was a tough year for the machine tool industry.
  - The global machine tool industry hasn't been growing.
    - We have experienced sales declines in some of our overseas markets.
      - 5 years ago, more than 57% of our revenue came from overseas markets.
        - Today, it's in the low 40% range.
      - **The good news is that in 2024, we grew in Europe, we grew 21%**
        - Haas is growing in North America and Europe!!!!
- Despite all these challenges, we stayed focused on our Strategy to Grow, and in 2024 we managed to grow Revenue from 2023.

# 2024 Final Numbers



- 2024 Numbers:
- We were positive on all our key metrics:
  - Revenue: \$1,075,000 (2023 was \$1,065B **increase of \$10M**)
  - Production: 10,381 (2023 was 10,055 **increase of nearly 300**)
  - Machine Orders: 10,400 (2023 was 9,515 **increase of nearly 885**)
  - Shipped Machines: 10,500 (2023 was 10,098 **increase of nearly 400**)
  - Rotary Tables Built: 2,021 (2023 was 1,757 **increase of nearly 264**)
  - Rotary Tables Sold: 2,055 (2023 was 1,894 **increase of nearly 161**)
  - Ecommerce Revenue: \$56 million (2023 was \$32 million, **increase of \$24M**)

# What to expect in 2025



**In 2025 and going forward, we plan on growing our business, regardless of what happens to the machine tool industry.**

**Our strategy is to expand our product line, grow our ecommerce business, and be aggressive with promotions and take market share.**

**North America and Europe are the growth engines of Haas!**

**Haas is focused on Growth  
and taking Market Share**

# 2025 Growth Strategy



- Here's our **Strategy to Grow** *(continued from 2024)*:
  - Improve the quality, reliability, and performance of all our machines.
  - Take market share from our competitors, with aggressive marketing promotions.
  - Increase the size and range of the Haas machine product line.
    - Haas engineered and designed
    - Naked machines
    - Private label
  - Expand and grow our Ecommerce business.
    - Supply everything that our customers need in their machines shops.

# 2025 Growth Strategy



- In 2025, we will continue this strategy:
  - We're going to be aggressive at taking business and expanding the product line.
    - Aggressive marketing promotions and low competitive prices.
      - Super low CNCA financing and subsidized European Bank financing.
    - **More than 25 New Products** will come to Europe for you to sell to our customers. (*More than 20 new products were released in 2024*)
    - Improve and update the look and performance of Haas machines in 2025
      - New look and colors of machines coming soon
      - 19" widescreen monitor
      - And stainless way covers coming soon
      - New higher performance processor
    - And as always . . . we will be sure we have machines in stock for quick delivery.

# Aggressive Pricing & Marketing



- In 2024, we had low pricing, low-cost financing, and aggressive marketing promotions in every market to help sell Haas machines.
- This will continue in 2025 . . .

WHAT'S NEW    AUTOMATION    FINANCING

View in browser



**HAAS AUTOMATION, INC.**  
**ROBOTIC PALLET LOADER**  
*Scalable, Affordable Pallet Loading Solution*

Enhance your machining with the Haas Robotic Pallet Loading System, designed for efficiency and automation. This package includes a 25 kg robot, advanced loading station, safety light curtain, pallet rack, and three zero point pallets – expandable to 15. Its plug-and-play design connects easily to Haas UMCs and small to medium VMCs. **Boost your production line with Haas precision and efficiency.**

**Starting price: \$99,995**

Learn More

WHAT'S NEW    AUTOMATION    FINANCING

ENDS JUNE 30TH!  
**UP TO 30% OFF**  
We are offering **HUGE DISCOUNTS** on Haas machines + Financing!

**30% 25% 20%**



- Large Vertical Mills
- Universal Machines
- VR Series
- Horizontal Mills
- Large Mold Machines
- Y-Axis Lathes
- All Rotaries
- Dual-Spindle

- Small Vertical Mills
- 2-Axis Lathes
- Small Mold Machines
- Gantry Mills
- Pallet-Changing VMCS

- Compact Mill & Lathe
- Drill / Tap / Mill
- 3-Axis Gantry Routers
- Extra-large VMC

**+ Even more savings and more models!**  
We're investing in you, so you can invest in your company.

START SAVING

WHAT'S NEW    AUTOMATION    FINANCING

DISCOVERING AUTOMATION

**LATHE AUTOMATION**  
Choosing the Right Automation for Your Haas Lathe



- Easy Automation**
- Affordable Automation**
- Versatile Automation**

- Bar Feeder** – Easiest of all possible automation choices to implement
- Automatic Parts Loader** – Emphasis on lowest possible price for Automation
- Robots** – Offer the most flexibility in implementation and part handling

WHAT'S NEW    AUTOMATION    FINANCING

**JOIN US AT EMEX!**



**WHAT**  
EMEX 2024  
Enjoy Live Demonstrations of Haas Tooling and Haas Machines.

**WHAT**  
28th May - 30th May 2024  
Don't Miss Out, Register Below to Attend!

**WHERE**  
Auckland Showrooms  
Booth 4040  
217 Green Lane West, Epsom, Auckland 1051



# CNCA Financing



- We're using our balance sheet to offer the **most attractive financing in the machine tool industry.**
  - Designed to take market share from our competitors.
  - Gene continues to invest in Haas Automation to grow our business.

CHOOSE YOUR FINANCING

<b>NO MODEL RESTRICTIONS</b>	<b>UP TO 6-MONTH SKIP AVAILABLE</b>	<b>NO PRE-PAYMENT PENALTIES EVER!</b>
<b>LOWEST DOWN PAYMENT</b> <b>10% DOWN</b> <small>0% Interest for as Long as 36-Months.</small>	<b>LOWEST INTEREST</b> <b>0% FOR 60 MONTHS</b> <small>Requires Larger Down Payment.</small>	<b>LONGEST TERM</b> <b>84-MONTH TERM</b> <small>With Rates as Low as 1.49%*</small>
<b>Payments as Low as €2.500 PER MONTH</b>	<b>Payments as Low as €1.167 PER MONTH</b>	<b>Payments as Low as €878 PER MONTH</b>

Sample payments are based on a €100,000 CNC machine purchase.

**SAVE €14.390 IN INTEREST!**  
(Based on 1.49% for 60 months, compared to lenders with similar terms at 6.66% interest.)

# New Products Strategy



- In 2023/2024 we changed our strategy for developing new machines.
- This new strategy focuses on supplying every possible machine that our customers may need in their machine shops.
- This strategy develops New Products (Machines) by 3 methods:
  1. Haas designed and manufactured at the factory (*just like we have always done*)
  2. Naked machines: we purchase machines from suppliers with castings, sheet metal, and other components, then add the Haas control and our IP
  3. Private-label machines (*machines built by other builders and branded Haas*)

# New Products Strategy



- Our goal is to offer our customers every machine, cutting tool, and “shop supply” that they might need.
  - All serviced & supported by the HFO network.
    - The HFO distribution network is the best in the machine tool industry, and we’re leveraging it to grow our business.
    - Basically, we’re building a One-Stop Shop for all our customers’ needs and requirements.
- Here’s a list of new products released, and product improvements coming soon:

# Haas Machines Are Being Upgraded in 2025



- **We're making Haas machines better:**
- **New updated look**
  - 19" widescreen monitor coming in 2025
  - New colors and decals
    - Flat black doors and accent sheet metal
  - Carbon fiber pendant, glovebox door, and RJH housing
  - New model decals
  - Higher performance Super Speed machines (rapids & spindle speeds)
  - And stainless steel way covers
  - And a new, higher-performance processor coming summer 2025



# Super Speeds Are Being Upgraded



- 2025 VF-2SS & VF-4SS (Super Speed family)
  - 40.6 m/min (1600 inch/min) rapids
  - 18,000-rpm 40-taper & HSK63A spindle options
  - Stainless steel way covers
  - 19-inch monitor
  - New colors and carbon fiber

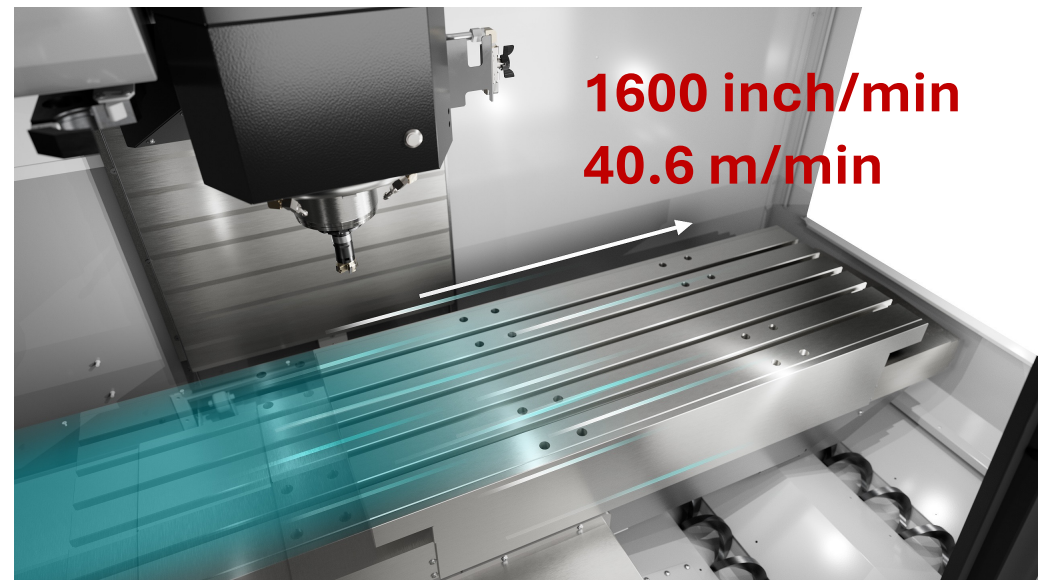
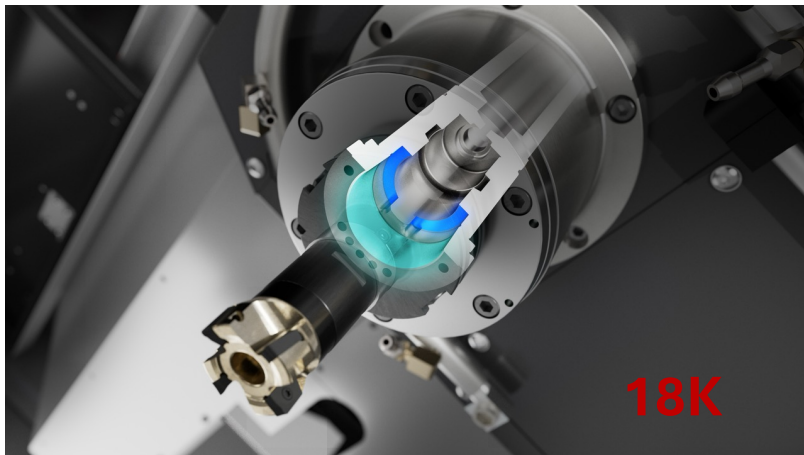

# Stainless Way Covers Are Coming



- All way covers will be updated to stainless steel
- Both mills and lathes
- Standard on:
  - All VF, VM, VR
  - ST-20, ST-30L, ST-40Ys
  - MM
  - CM/CL
- Coming soon:
  - Apr - ECs
  - May – ST-10/30
  - TBD – DT/DM

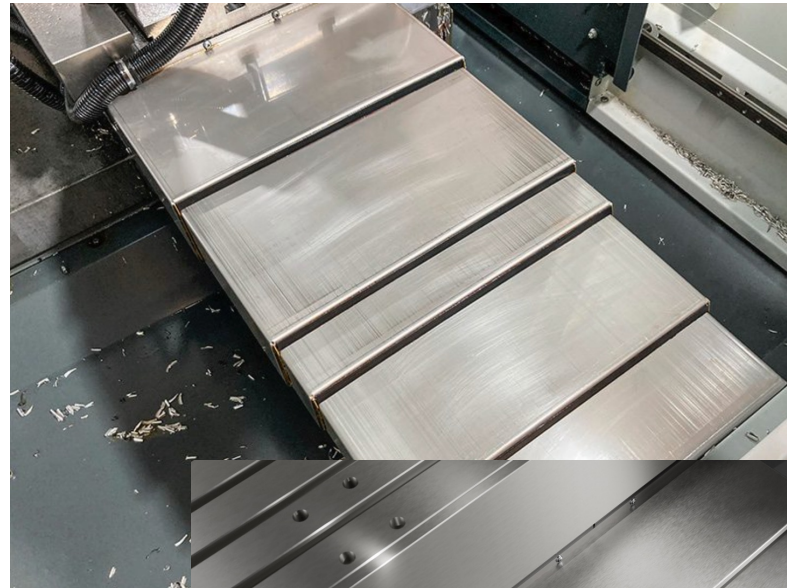

# 2024 New Products



- UMC-400 & UMC-400SS
  - 5-axis entry-level UMC with a small footprint
  - 432mm x 279mm x 300mm travels
  - 230mm platter
  - Released for sale Sept 2024
    - Deliveries happening now
    - 25 sold so far
  - Note:
    - Chip auger only
    - 30+1 SMTC only
    - 23% smaller than UMC-500



# 2024 New Products



- DC-1

- Turret-Style Drill/Tap machine with small footprint
  - 10k to 20k BT30 spindle
- 77 sold since release in Q1-2024
- Great performance and price – Haas Value!
- The first of a complete family of DCs



# DC-1 *Example of Naked Machine*



- What it comes with from supplier:
  - THK, HIWIN, or Rexroth linear guides and ballscrews
  - Spindle
  - Tool changer
  - Oil lubrication system
  - Coolant tank
- What we add at the factory (Haas IP)
  - Haas CNC control
  - Spindle motor & servomotors
  - Spindle chiller
  - Solenoids and manifold for lube
  - TSC system (union and pump)
  - Flood coolant pump (VFD, HCFP)
  - Work lights
  - Auto window
  - Haas convenience package



# 2024 New Products



- DC-2
  - Already expanding the DC-1 family
    - 10k to 20k BT30 spindle
  - Large, heavy machine: 19,000 kg
- 8 sold so far



# 2024 New Products



- TL-1P and TL-2P
  - Production version of the Toolroom Lathes
  - Includes:
    - 3000-rpm A2-5 spindle
    - 4-station automatic tool turret
    - **New** 6.5" chuck with hydraulic closer and HPU
  - 9 sold so far
    - 5 TL-1P
    - 4 TL-2P



# 2024 New Products



- Desktop Lathe
  - Released Q2-2024
  - 100 sold
  - Complements the Desktop Mill
    - Over 1,300 Desktop Mills sold....



# 2024 New Products



- ST-40s with Y-axis
  - BMT75 live tooling and  $\pm 3''$  (76mm) Y-axis travel
  - 35 sold
    - 19 ST-40Y
    - 12 ST-45Y
    - 4 ST-40SY



# 2024 New Products



- ST-40 with a short bed
  - Short Z-axis travel ST-40s for smaller footprint
    - 11% smaller than standard ST-40s
    - 30% smaller than long-bed ST-40s
      - 28" (711mm) Z-axis travel
  - Available with Y-axis
    - ST-40S – 6 sold
    - ST-40SY – 4 sold
    - ST-45S – 1 sold
    - ST-45SY – none yet



# 2024 New Products



- HDC-3-5AX
  - Double-column, 5-axis machine
  - HDC-3-5AX - \$999,995
    - 1st Haas machine at one million dollars!
  - 4 installed at Haas factory
  - 7 sold in USA
- Available for sale March 2025 for HAE



# 2024 New Products



- New VR Head
  - Haas designed VR head
  - Updated design w/ brakes on each side
  - More robust design
  - Best VR head ever!

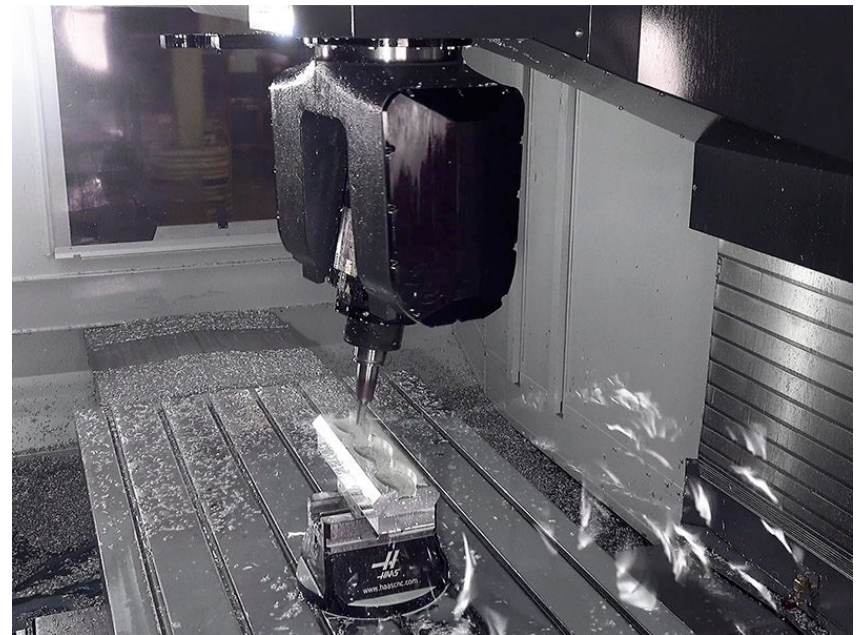

# 2024 New Products



- SR-3015 Haas Router
  - Sheet router for non-metallic materials
    - Haas stepper CNC control
    - 3000 x 1500 x 200 mm travels
    - 4.5 kW, ER32 air-cooled spindle
    - Dust collection system and tool setter standard
  - 8 sold
- SR-3015P Production Version
  - BT30 spindle
  - Rack-style tool changer
  - Vacuum table
  - 15 sold
- We plan on having an entire line of these of machines
- Available for sale March 2025 for HAE



# 2024 New Products



- HAB-3232 Haas Band Saw
  - Private labeled
  - 320mm x 320mm capacity
  - Blade size: 4.1m x 33mm x 1mm
  - 0.8m – 6.6m/min cutting speeds
  - Easy-to-use touchscreen interface
  - European models coming early 2025
  - 49 sold

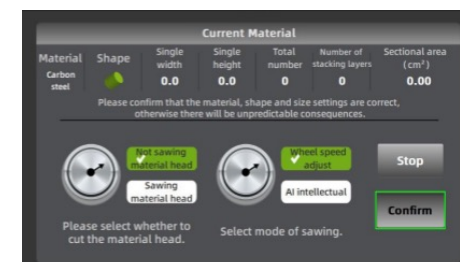
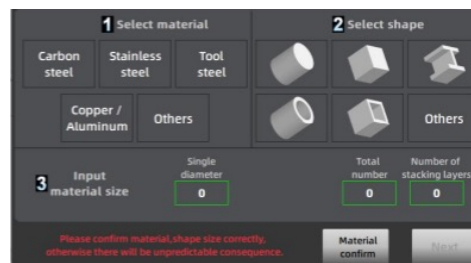

# 2024 New Products



- HSG-2550 Haas Surface Grinder
  - Private labeled
  - 250 x 500mm electromag chuck
    - 3450 rpm
  - 200mm x 20mm wheel size
    - USA only
  - 3 sold
  - HAE availability TBD

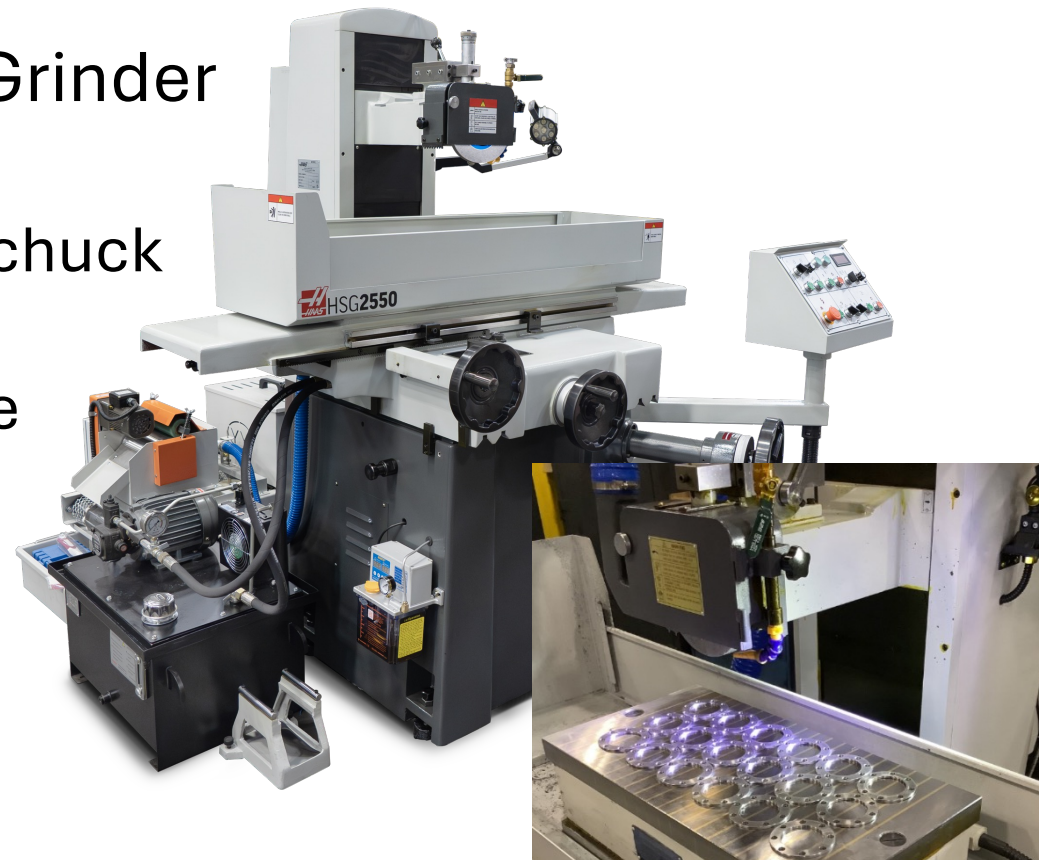

# 2024 New Products



- HMM-430 Haas CMM

- Private labeled

- 400 x 430 x 350mm travels
- Renishaw linear scales 0.001mm (0.00004") all axes
- Renishaw MH20i probe and TP20 SF module
  - Servomotor driven
  - DIN 876 grade granite base
- Industry standard GeoCAD+ software
  - PC and 24" monitor included

- Super low price of €49,995

- 8 sold

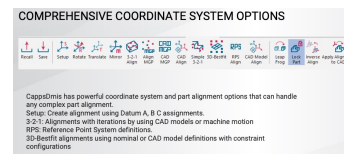
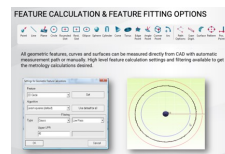

- Available for sale March 2025 for HAE

# 2024 New Products



- HL50E Laser Marker
  - Private labeled
    - Haas Laser Marker
      - Suitable for steel, alloy steel, stainless, brass, aluminum, iron, and some non-metal materials
      - 50W fiber laser, air-cooled
      - 50 x 50mm marking range
    - 55 sold in US
    - €12,995
- Available for sale March 2025 for HAE



# 2024 New Products



- Haas Air Compressor
  - Private labeled
  - Rotary screw compressor
  - 15 hp (11kW)
  - Includes
    - Refrigerated Air Dryer
  - Low price of €9,995.95
    - March 2025 release for sale for HAE
    - 59 variable speed sold
    - 17 fixed speed sold
  - Already expanding to add larger units



# Automation

2024

# Automation Strategy



- Five years ago, we had very few automation options available for our customers
- Today, we have more than just about every other machine tool builder out there!
- Over the last 5 years, we have developed:
  1. Pallet pools
  2. APLs
  3. Private-labeled robots and cobots
  4. Rotary tables and bar feeders
- *Automation is now available on more than 80 Haas machine models!*

# 5 of CNCs w/ Automation

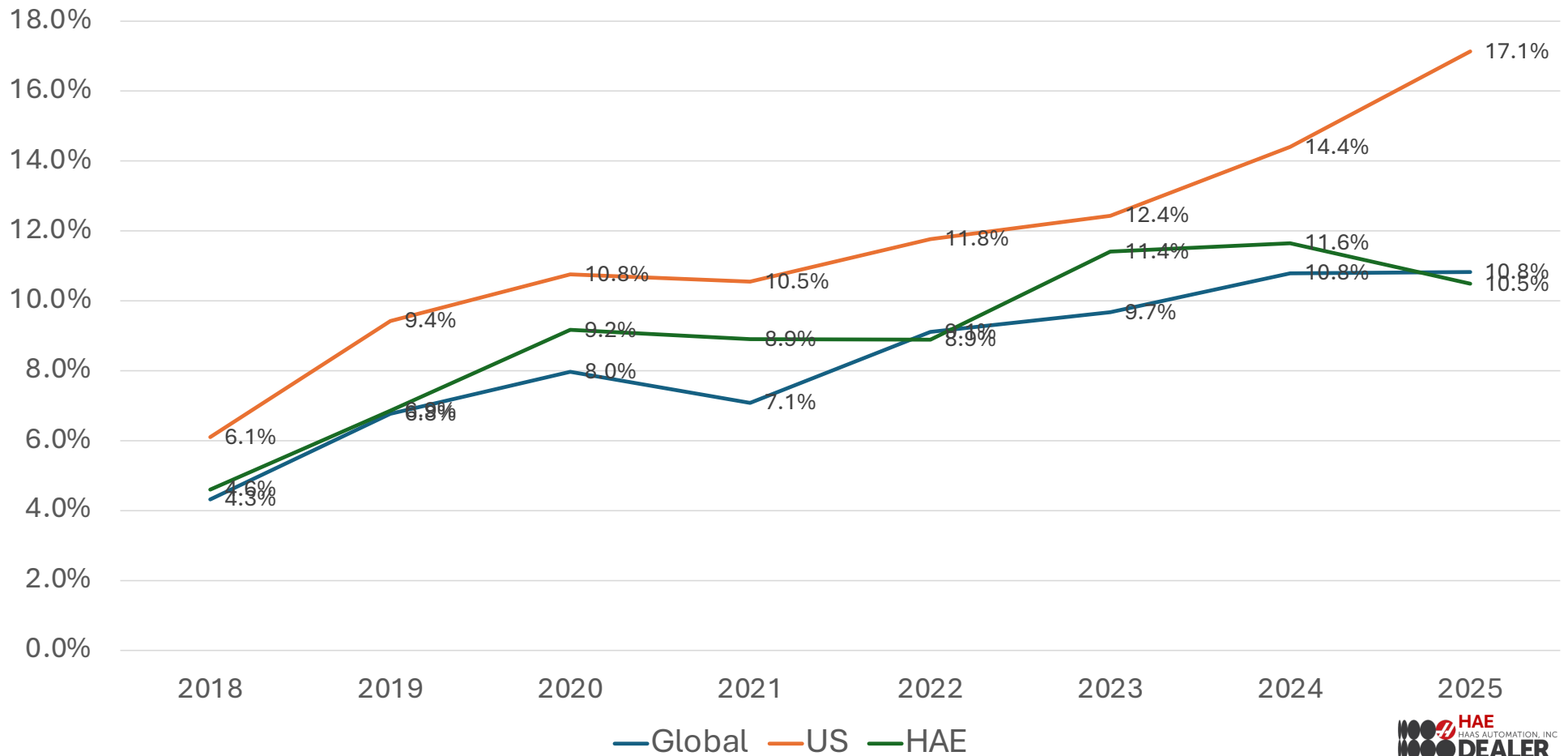

# New Automation: Cobots



- Full line of Haas-branded cobots
- 107 sold
- Program with Haas control or Hans controller



5kg  
€24,895  
1 sold



10kg  
€28,695  
81 sold



15kg  
€41,995  
25 sold



30kg  
€59,995  
Release Q1-25

# New Automation: Robotic Pallet Loader



- Available for:
  - UMC-500/750/1000
  - VF-1/2/3/4/5
- 20 sold
  - 15 UMCs
  - 5 VFs
- Integrated with the Haas control for easy set up and pallet scheduling
- 2<sup>nd</sup> shelf coming Q2-2025



Operator	Value	Units
Number of Columns	3	
Number of Rows	3	
Distance Between Columns	0.000	MM
Distance Between Rows	0.000	MM
Raw Pallet Mass	0.000	kg
Total Pallets	3	

# Extensive Robot Offerings



- Robots are available for more than 80 different Haas machine models



# Robot Options



- No easier integration of cobots/robots and CNC control than Haas
- Multiple material handling, safety, and gripper options

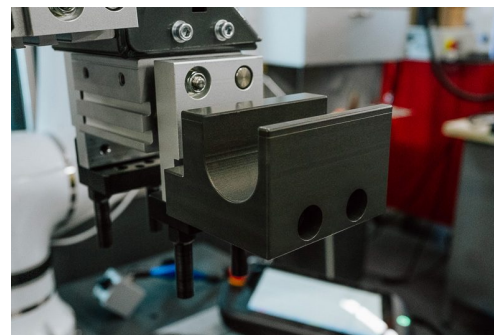
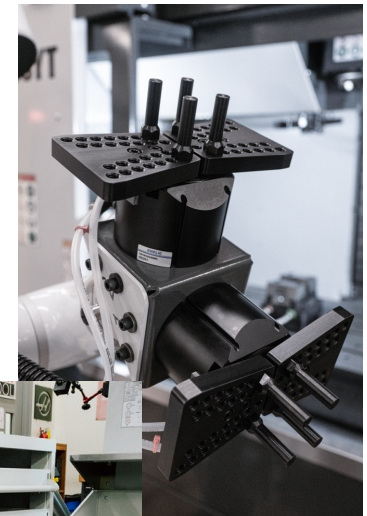
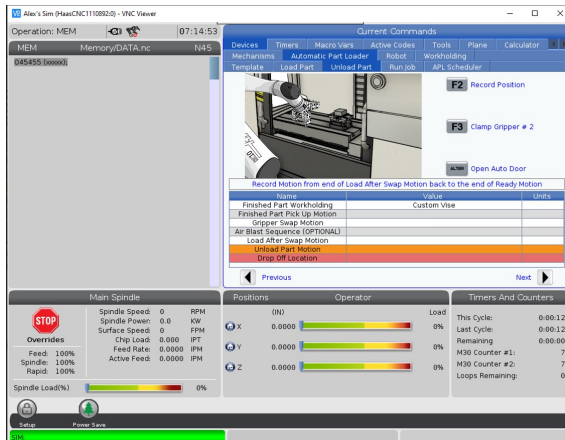

# New Pallet Pool



- VF-4 pallet Pool
  - Expanded to VF-4, based on the success of the VF-2 Pallet Pool
  - 4 sold
- VF-2 Pallet Pool
  - 126 sold since 2022

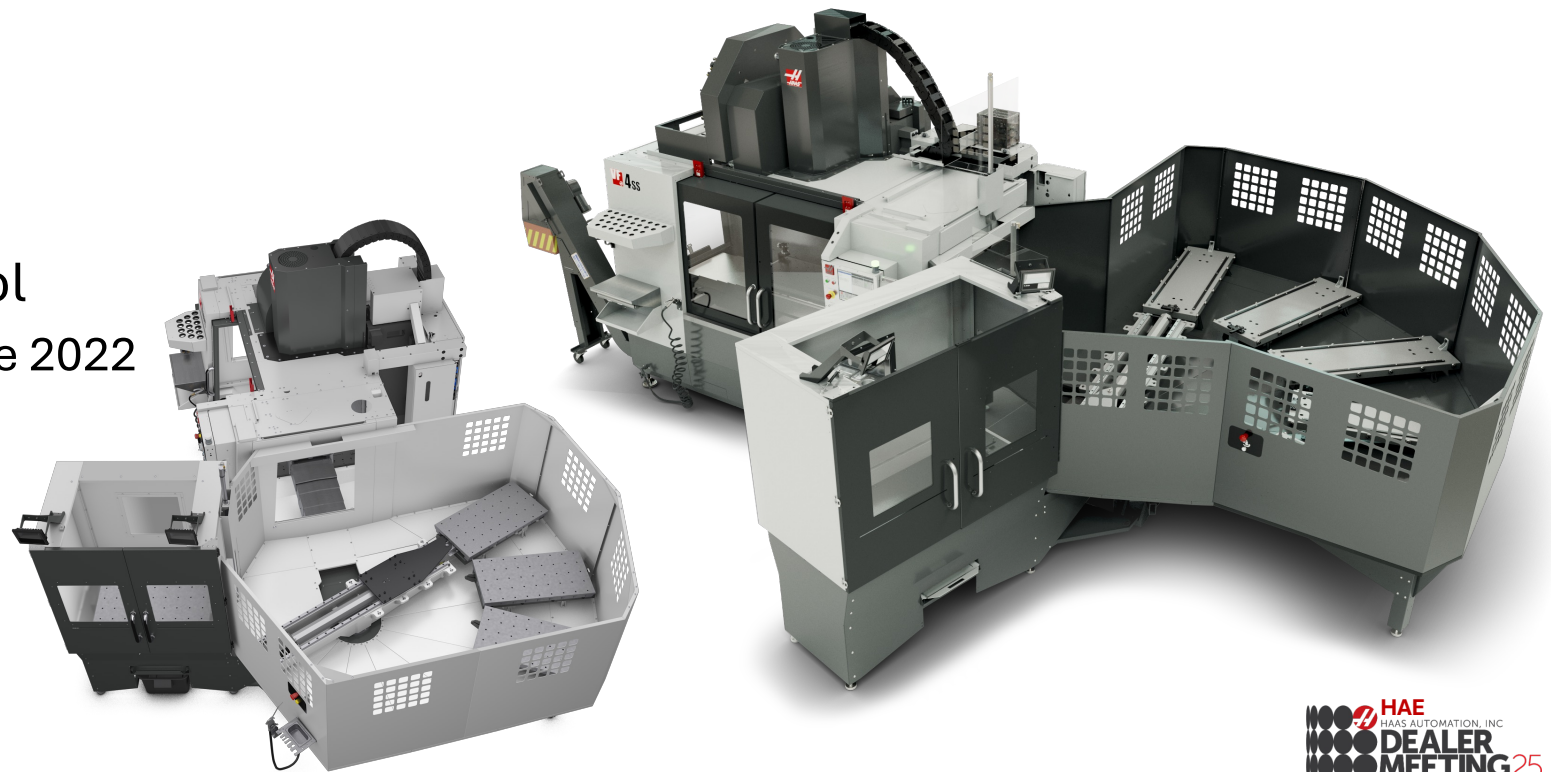

# Pallet Pools for VMC, HMC, and UMC

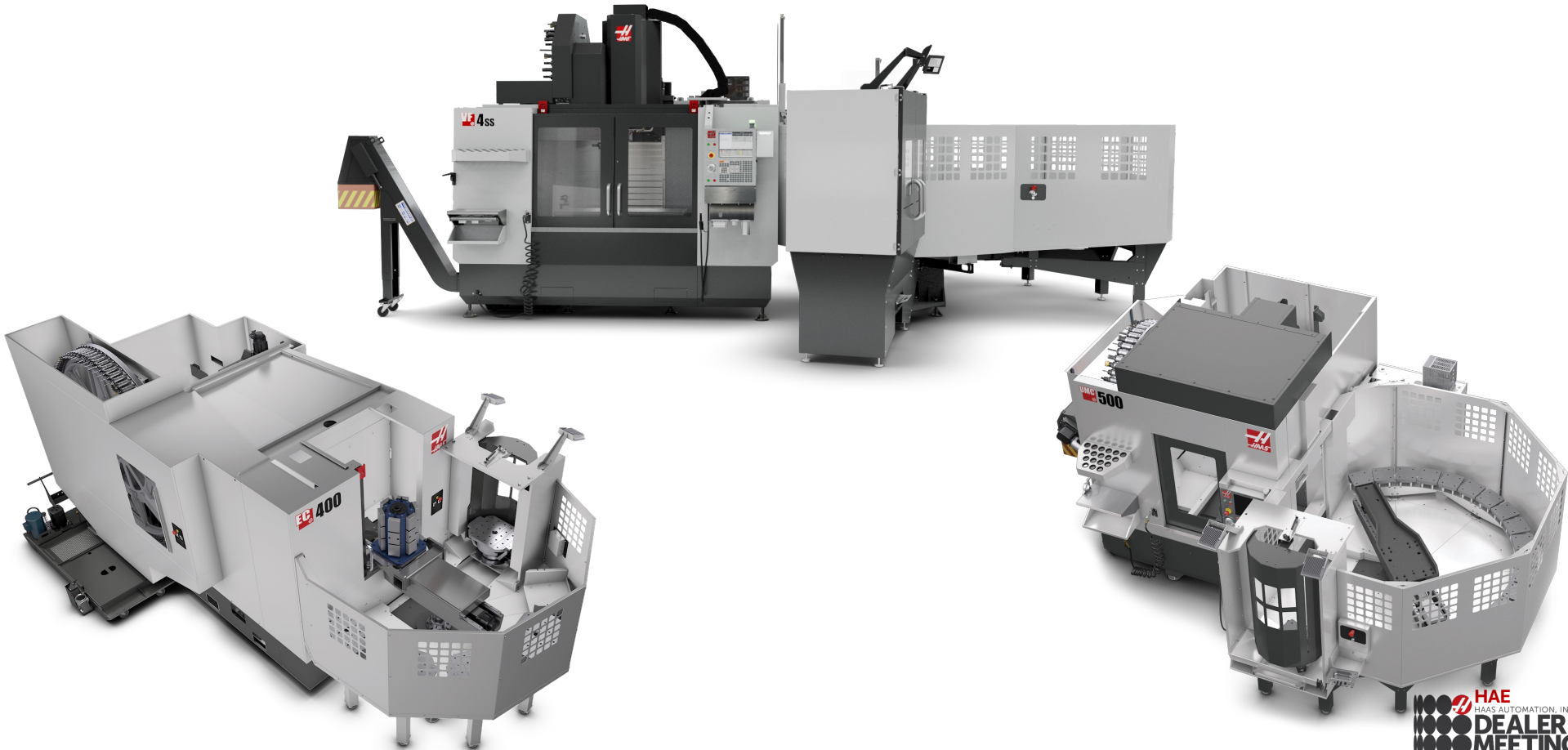

**HAE**  
HAAS AUTOMATION, INC.  
**DEALER**  
**MEETING 25**

# Full Automation Line Up



## MILL AUTOMATION LATHE AUTOMATION

### MILL PALLET POOLS



**VMC**

**3+1 Pallet Pool**  
VF-2YT VM-2  
VF-2SSYT



**5+1 Pallet Pool**  
VF-4  
VF-4SS



**6+1 Pallet Pool**  
VF-2YT VM-2  
VF-2SSYT

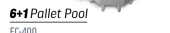

**6+1 Pallet Pool**  
EC-400

### MILL AUTOMATIC PARTS LOADERS



**UMC**

**10+1 Pallet Pool**  
UMC-500 UMC-500SS  
UMC-750 UMC-750SS  
UMC-1000 UMC-1000SS



**20+1 Pallet Pool**  
UMC-500  
UMC-500SS



**COMPACT AUTOMATIC PARTS LOADER**  
Mini Mill DC-1  
DTs DMs  
VF-2 VF-2SS  
VF-2YT VF-2SSYT

### MILL ROBOTS



**COBOT 5kg**  
COMING Q2 2024



**COBOT 10kg**  
MM SM4  
DT/DM Models  
COMING Q2 2024



**COBOT 15kg**  
COMING Q2 2024



**7kg CAPACITY ROBOT SYSTEM**  
DT/DM Models  
VF-1 to VF-2  
UMC-500 UMC-500SS



**25kg CAPACITY ROBOT SYSTEM**  
VF-1 to VF-5  
UMC-500 UMC-500SS  
UMC-750 UMC-750SS  
UMC-1000 UMC-1000SS



**50kg CAPACITY ROBOT SYSTEM**  
VF-6 to VF-11



**ROBOTIC PALLET LOADER**  
All UMCs  
VF-1 to VF-5  
VM-2, VM-3

### HAAAS BAR FEEDER



**HAAAS BAR FEEDER**  
ST-10 to ST-35



**HAAAS BAR FEEDER**  
ST-10 to ST-35

### LATHE AUTOMATIC PARTS LOADERS



**LATHE AUTOMATIC PARTS LOADER**  
ST-10Y ST-20 ST-25 ST-28  
ST-15Y ST-20Y ST-25Y ST-28Y

### LATHE ROBOTS



**COBOT 5kg**  
COMING Q2 2024



**COBOT 10kg**  
ST-10 to ST-28



**COBOT 15kg**  
COMING Q2 2024



**7kg CAPACITY ROBOT SYSTEM**  
ST-10 to ST-28



**25kg CAPACITY ROBOT SYSTEM**  
ST-20 to ST-35  
DS-30Y



**50kg CAPACITY ROBOT SYSTEM**  
ST-30 to ST-35

**And we even have more  
New Machines coming in  
2025**

# Coming in 2025



- LT350
  - Large-through-hole rotary table
  - 350mm platter
  - 200mm through-hole
  - Riser and chuck options

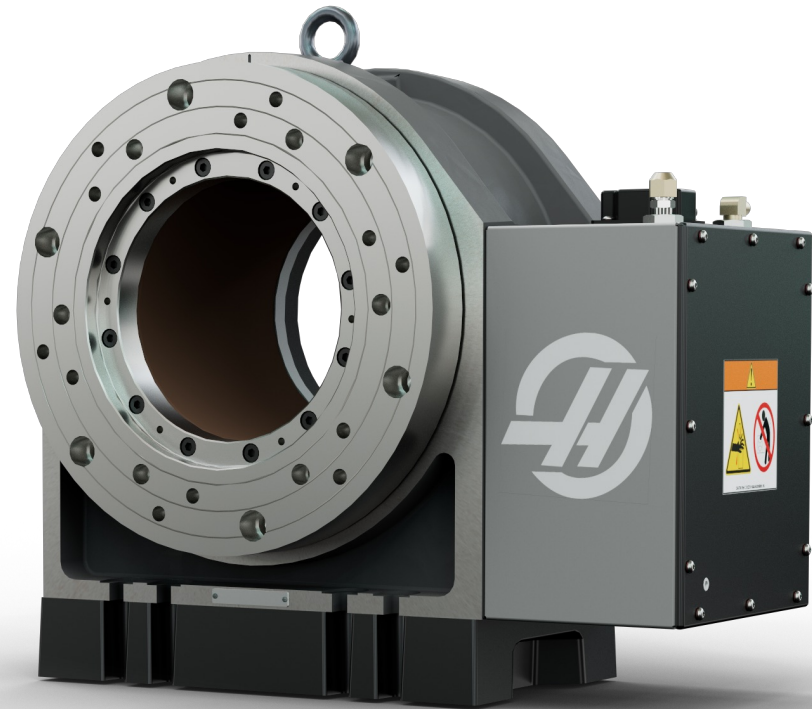

# Coming in 2025



- GM-1
  - 121" x 61" 16" (3073 x 1549 x 406mm) travels
  - Inline drive spindle
    - 8.1k standard, up to 15k optional
  - 30+1 side-mount tool changer
  - All cast iron construction
  - Available Q1-2025



# Coming in 2025



- ST-40LY and ST-45LY
  - BMT75 live tooling and  $\pm 76\text{mm}$  Y-axis travel on the long-bed platform

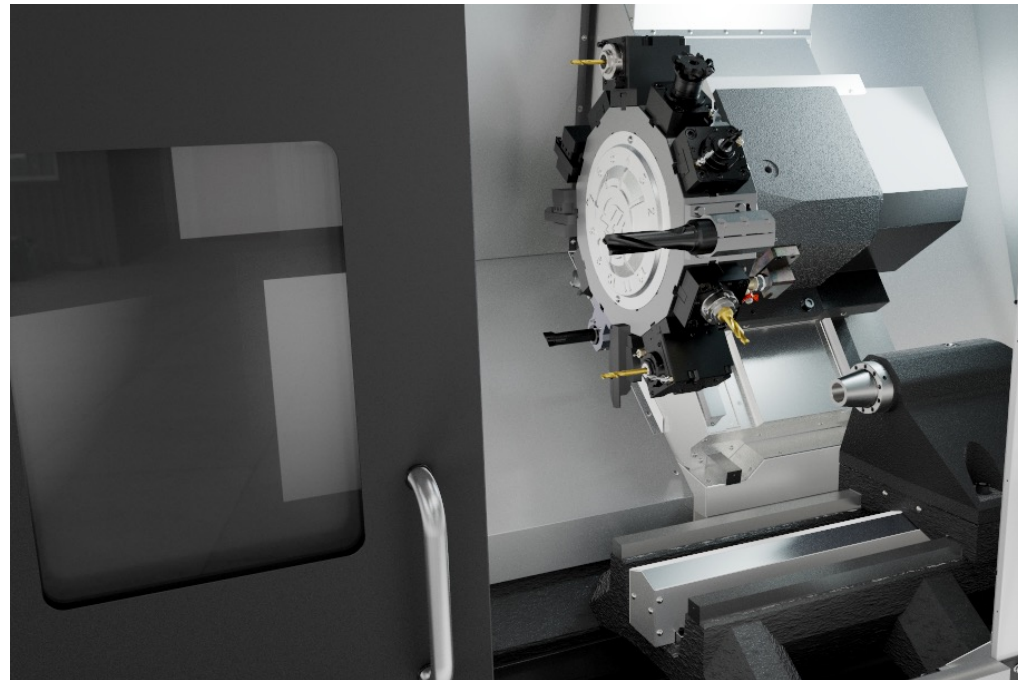

# Coming in 2025



- Haas Knee Mill
  - Private labeled
  - Traditional knee mill
    - 32.7" x 12" x 16" travels (831 x 305 x 406mm)
    - Variable speed R8 spindle, 4500 rpm, 5 hp (3.7kW)
    - Pneumatic power drawbar
    - X-axis power feed w/clutch handles
    - XY DRO
    - Coolant system w/chip tray
    - Auto lube system
- Q2-2025



# Coming in 2025



- DT-3 and DM-3
- Expanded travels in X-axis, but with DT/DM-2 footprint
  - 914mm x 406mm x 394mm travels (DT/DM-2 is 711 mm in X-axis)
  - 29% more travel in same footprint
- Same spindle and tool changer configurations as DT/DMs
- Same options as DT/DMs
  - DT-3 – 1 sold
  - DM-3 – 1 sold
- Available to sell now
- Q1-2025 shipping



# Coming in 2025



- Side-Loading APL for small VFs
- Available to sell now



# Coming in 2025



- New Haas tool pre-setter . . . 2 more models coming
- HTS600 (400 x 600mm)
  - Tabletop
  - Pneumatic:
    - Axis Clamping
  - Interchangeable ISO/SK/BT 40, 50, HSK63a, HSK100
  - €18,995.95
  - For sale end of Feb 2025
- HPTS600 (400 x 600mm)
  - Performance Model
  - Floor Unit
  - Pneumatic:
    - Pneumatic Tool Locking Mechanism Interlock System
    - Pneumatic Axis Clamping
    - Pneumatic Sleeve Rotation Brake Clamping
  - €24,995.95
  - For sale end of Feb 2025
- HTS400 (existing tool presetter)
  - \$12,995.95
  - 216 sold ←



# Coming in 2025



- DC-1/40 and DC-2/40
  - 40-taper versions of the DC-1 and DC-2
  - 12,000 rpm, 40-taper spindle
  - 20-tool, turret-style tool changer
  - Available now
    - 2 DC-1/40 sold
    - 1 DC-2/40 sold
  - Shipping Q1-2025



# Coming in 2025



- DC-3 and DC-4
  - Expanded DC line up, longer X-travel, 12,000 rpm, 40-taper spindle
    - 20-tool, turret style tool changer
    - CT40 spindle
  - DC-3
    - 2000mm x 500mm x 300mm
  - DC-4
    - 2500mm x 500mm x 300mm
  - Available now
  - Shipping Q2-2025



# Boxway Lathe



3<sup>rd</sup> Party Machine



# Boxway Lathe



- Testing A2-8 Y-axis lathe w/ BMT65 tooling
- SB-28Y
- Available for sale March 2025 for HAE
- Q2-2025 shipments

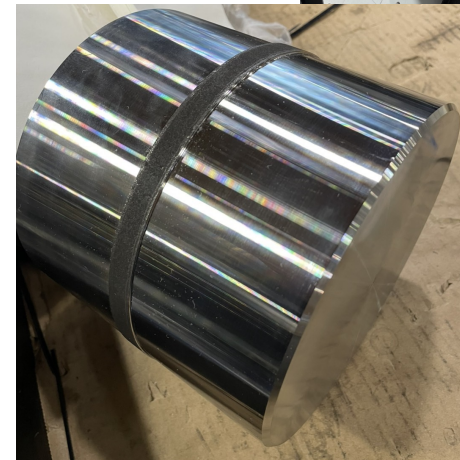
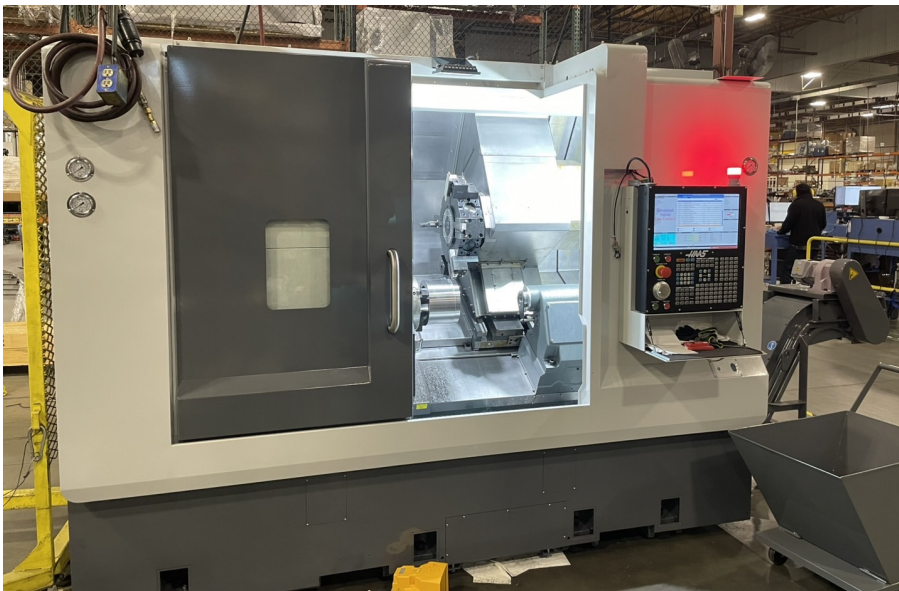

# SR-3015P-4AX , SR-4020 and SR-4020P



- SR-3015P-4AX
  - 4<sup>th</sup> Axis rotary off to side of bed
  - Haas servo control
  - BT30
  - 8-station wine rack tool changer
- SR-4020
  - Larger version of SR-3015
  - 4m x 2m
  - Haas stepper control
- SR-4020P
  - Larger version of SR-3015P
  - 4m x 2m
  - Haas servo control
  - BT30
  - 8-station wine rack tool changer
- Q2 available for sale for HAE

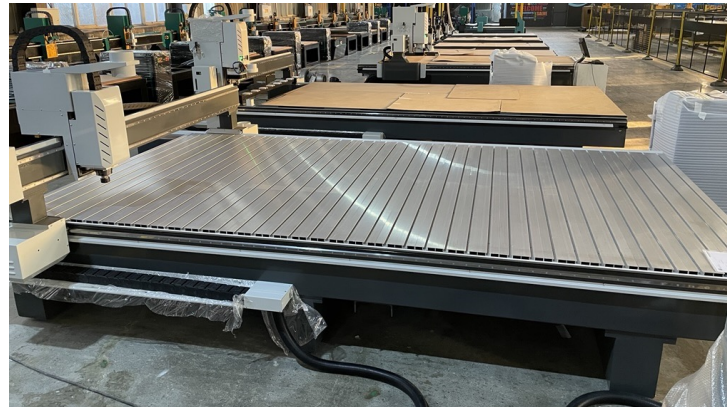

# HFL-3015



- 3kW Fiber laser
- 3m x 1.5m (10' x 5')
- Pallet changer
- Installing first unit at Haas Sheet Metal Feb 2025
- Release for sale March 2025 US/CA/MX
- Deliveries Q3-2025
- \$139,995 est



3<sup>rd</sup> Party Machine

# Band Saws



- HVS-1
  - Vertical band saw
  - ~\$15k
  - Q2 release for sale
  - Q2 deliveries
  - Working on CE version



- HMS-1
  - Mitering horizontal band saw
  - ~\$10k
  - Q2 release for sale
  - Q2 deliveries
  - Working on CE version

3<sup>rd</sup> Party Machine

# 120 Pocket SMTC for UMCs



- For UMC-500, 750 and 1000
- Q2-2025 release for sale
- Q3-2025 deliveries

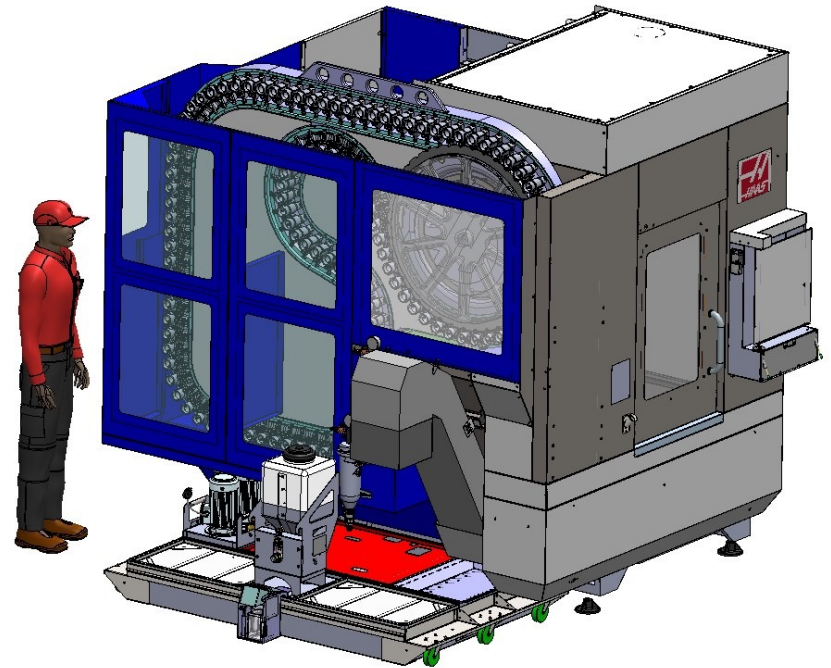
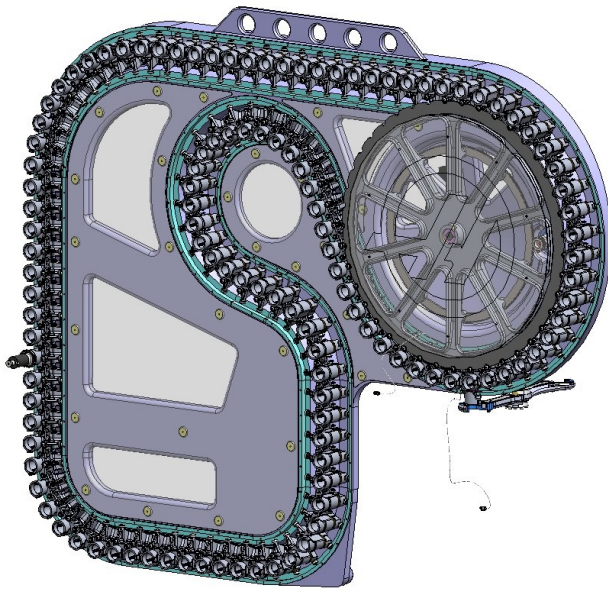

# EC-1600ZT Pallet Pool



- 5 pallets
- Available only for EC-1600ZT
- Q2-2025 release for sale
- Q3-2025 deliveries
- ~\$160k for pallet pool
- Machine and pallet pool for the low \$400K

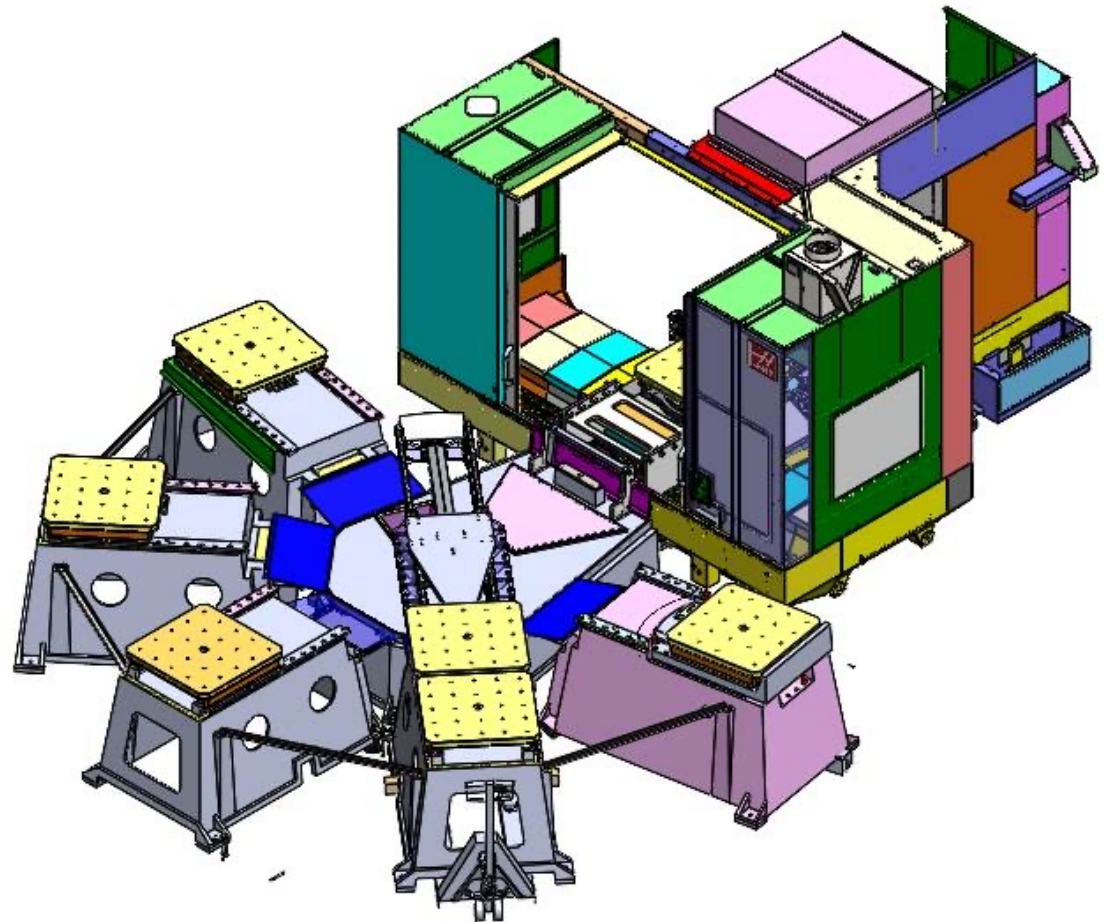

# UMC-1100



- HSK100 version of UMC built on UMC-1250 frame
- Integral spindle motor or Haas inline spindle
- Q2-2025 release for sale
- Q3-2025 deliveries
- ~\$350k

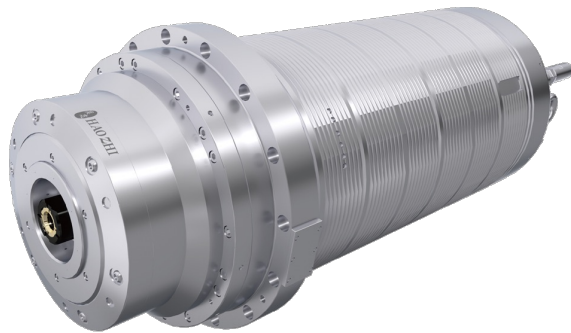

# New Products



We are aggressively developing and expanding the product line!

It's important that you get your “sales organizations” up to speed and selling these new machines.

# Haas Tooling & Ecom Update

# E-Com Sales Growth



- More than \$125,000,000 sold in Haas Tooling since July 2020
- 2025 is \$100,000,000 annually

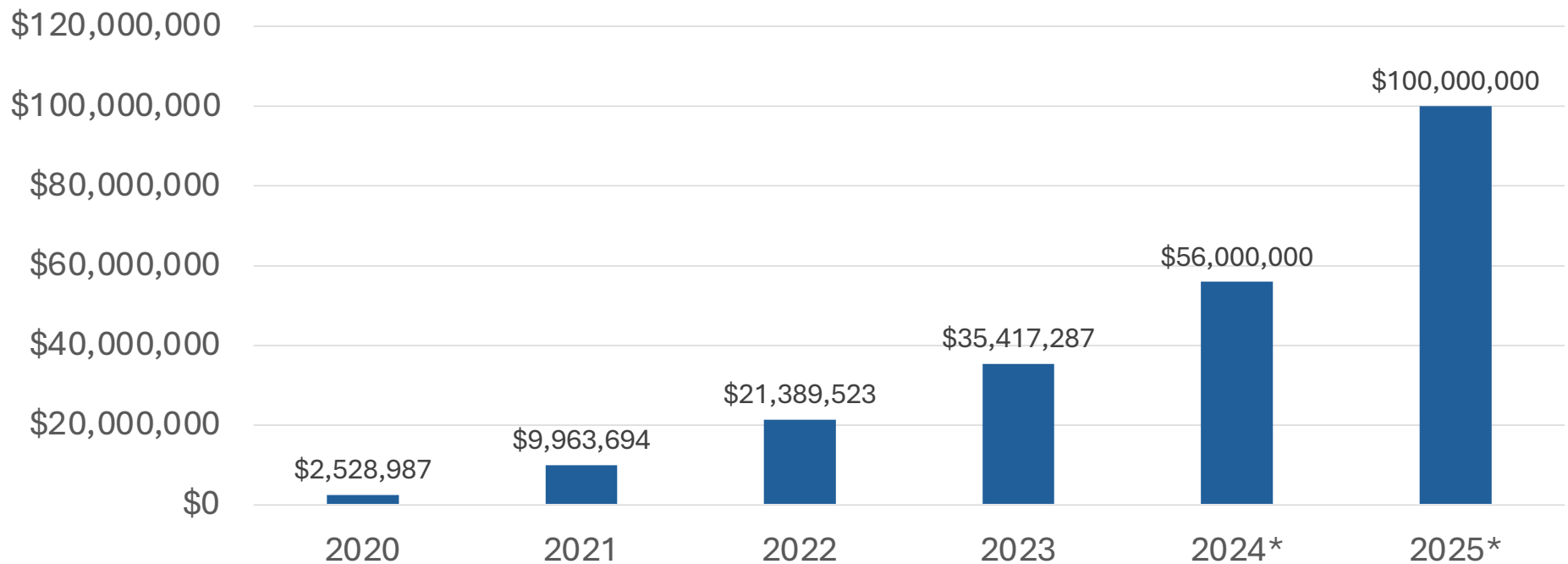

# E-Com HAE Sales Growth



- More than \$12,000,000 sold in Haas Tooling since July 2022
- 2025 goal is \$15,000,000 in revenue

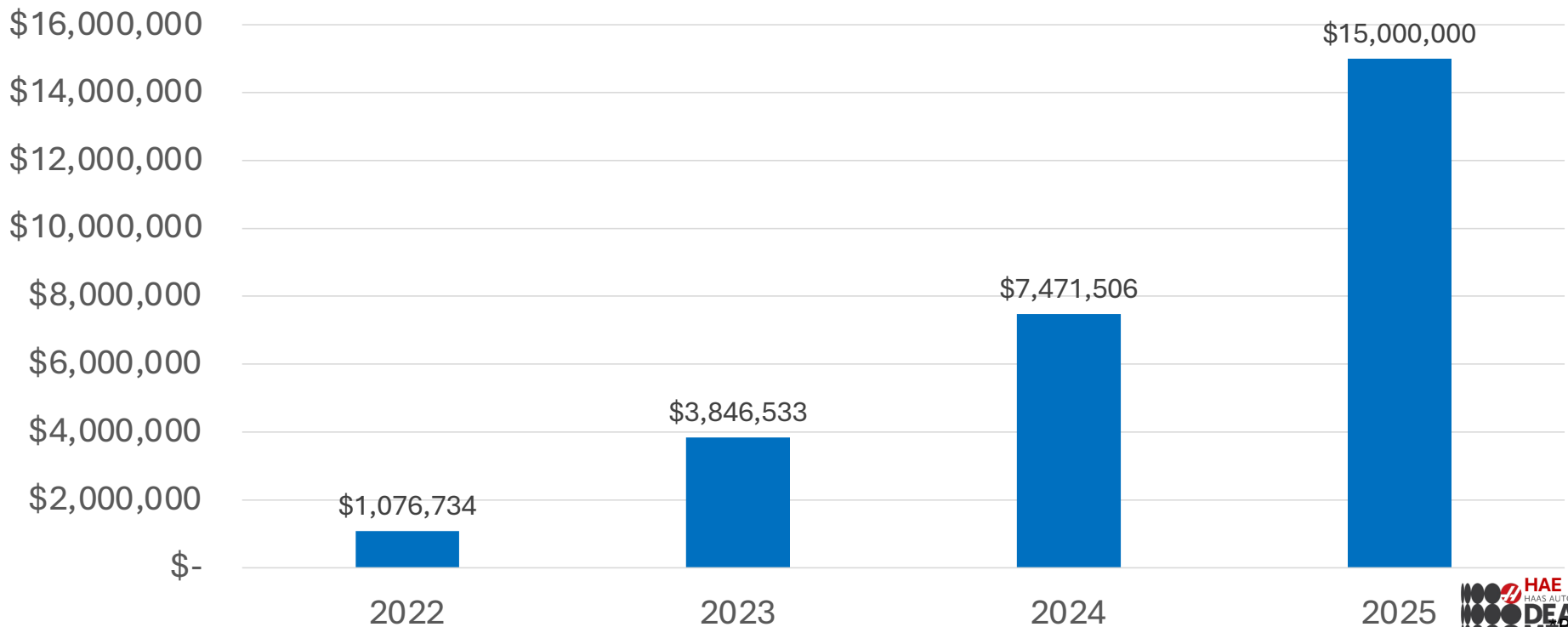

# Where Tooling Sales Are Coming From



- Web Tooling Sales grew 69% (61% of total 2024 sales)
- HFO Tooling Sales grew 51% (39% of total 2024 sales)

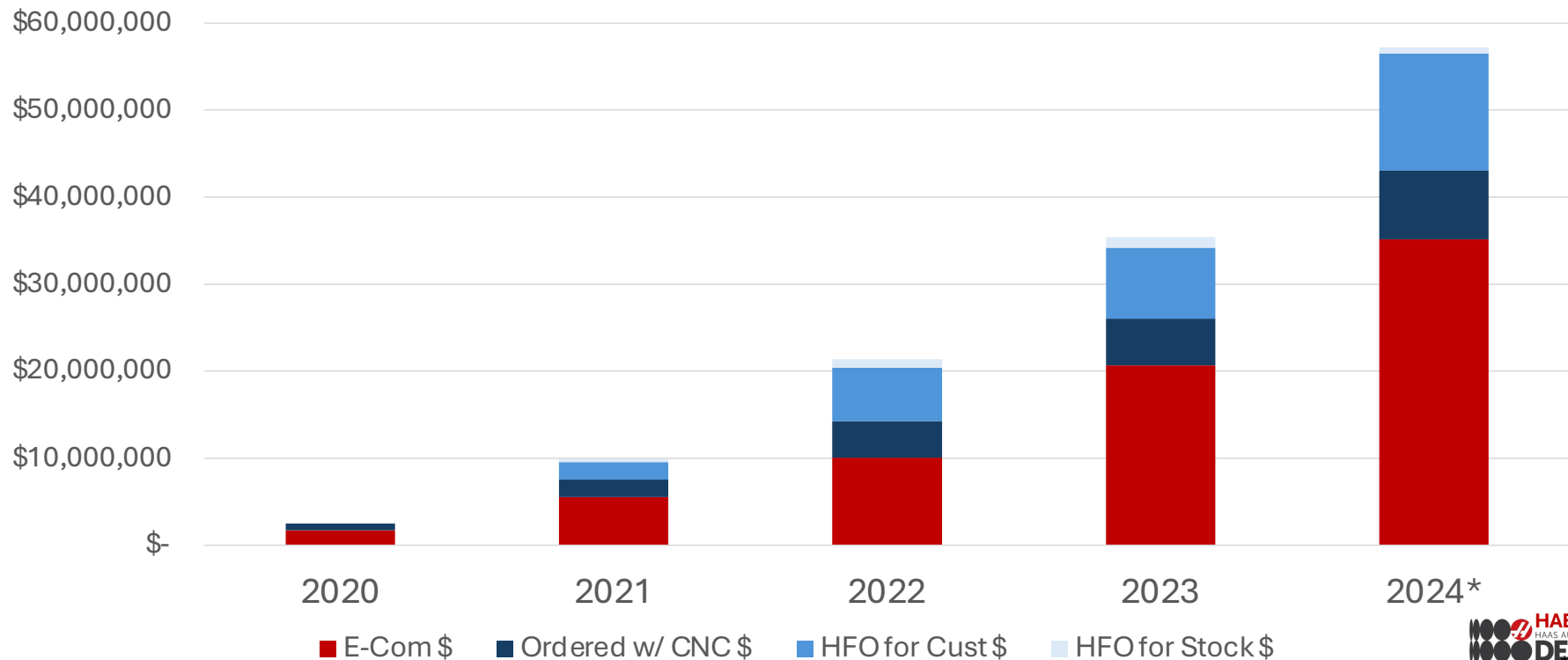

# 2023 vs 2024 Ecom Sales



## Month over Month:

- Nov 1-30: 2023: **\$4,732,845**
- Nov 1-30: 2024: **\$7,424,335**
- **+57% from 2023 (+\$2,691,490)**

## Year to Date:

- Week 1-50: 2023: **\$33,657,861**
- Week 1-50: 2024: **\$54,486,763**
- **+62% from 2023 (+\$20,828,901)**

## 2024 VS. 2023 MONTHLY SALES

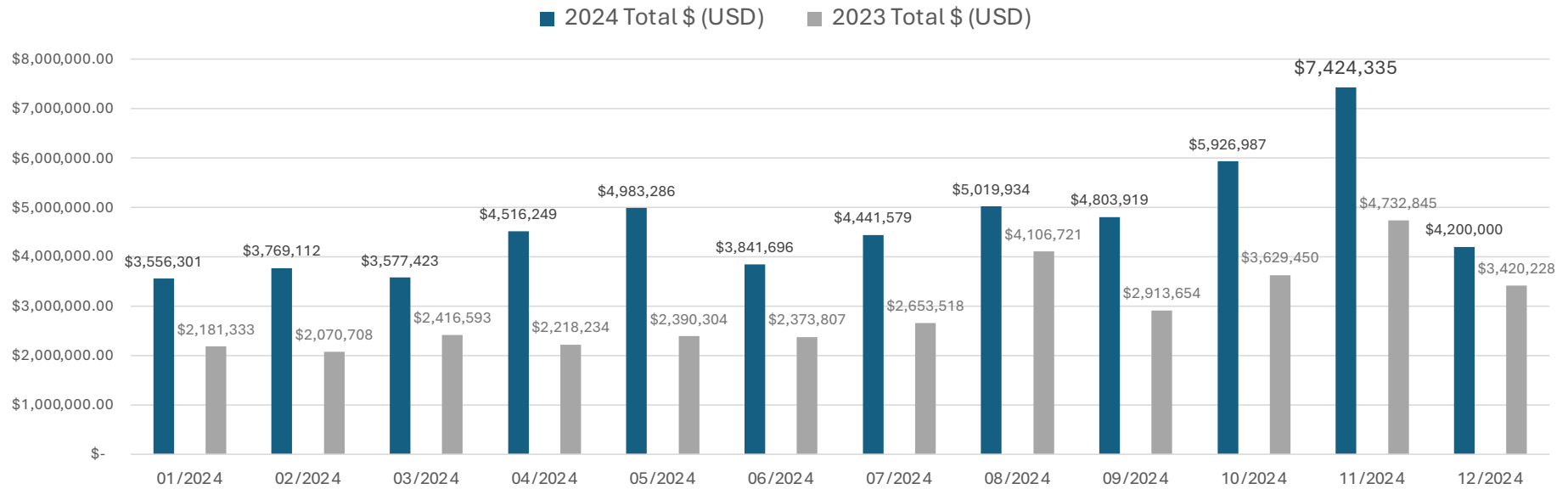

# Customer Acquisition



Tooling Customer Growth by Week  
56% Growth this Year

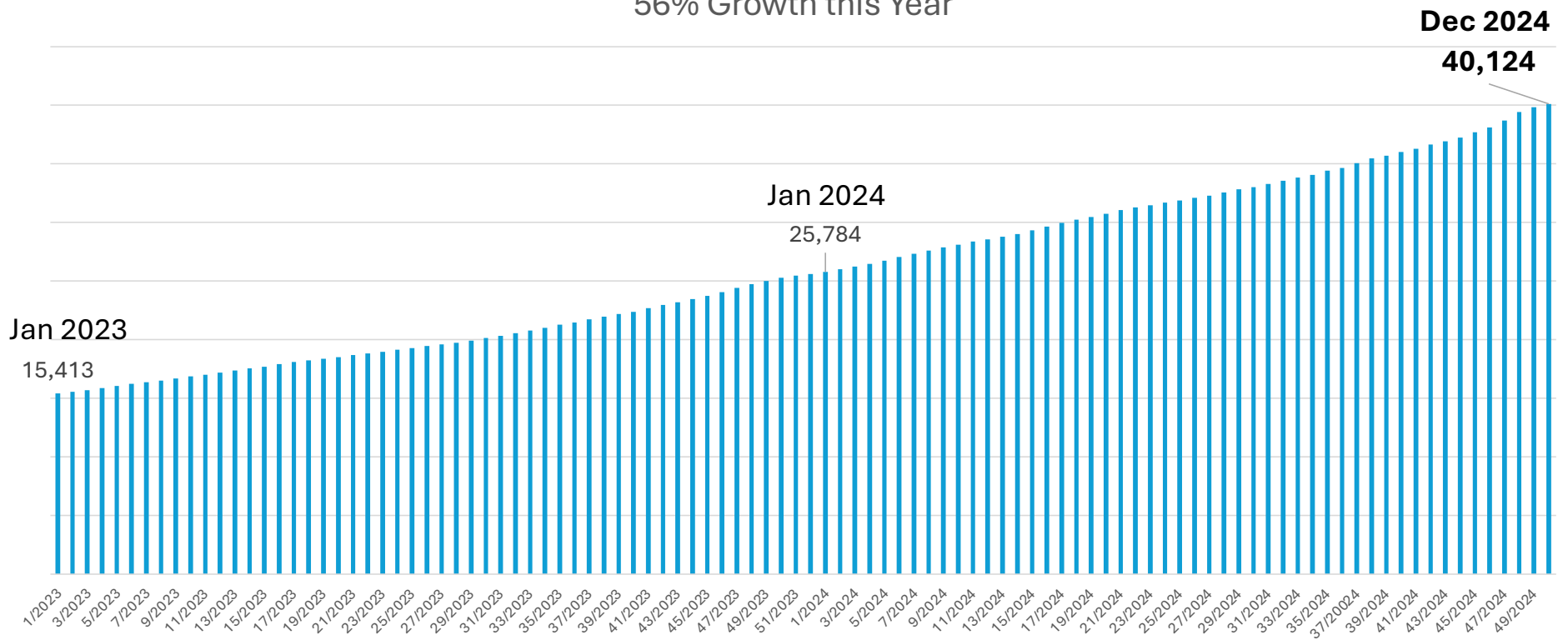

# Winner's Circle Update



- Loyalty program added
- Tier discounts from 5% to 8%
- Haas Bucks allow users to earn credit toward CNC purchases
  - 10 machines w/ Haas Bucks applied
    - VF-14, UMC-500SS, (2) VF-2SSYT, (2) DC-1, MM, VF-4, ST-35, VF-3YT/50
  - 2 rotaries w/ Haas Bucks applied
    - HA5C-T, HRT160
- More than 10,000 members and growing
  - Represents almost 63% of tooling revenue
  - Purchase 41% more frequently each month

**TOOLING.com**  
**HAAS**

**WINNER'S CIRCLE**

**FREE**  
NEXT-DAY DELIVERY

**UP TO 8% OFF**  
ENTIRE ORDER

**HFO + ONLINE**  
ORDER 2 WAYS!

**FREE SHIPPING**  
ON ALL ORDERS OVER \$49

**ONE MEMBERSHIP**  
FOR ENTIRE COMPANY

**COMBINE**  
WITH OTHER PROMOTIONS

INTRODUCING OUR NEW  
**LOYALTY REWARDS PROGRAM**

STANDARD	BRONZE TIER SPEND \$10,000+	SILVER TIER SPEND \$25,000+	GOLD TIER SPEND \$50,000+
5% SAVINGS	6% SAVINGS	7% SAVINGS	8% SAVINGS

SAVINGS BASED ON ANNUAL HAAS TOOLING SPENDING.

**HAAS BUCKS**  
TURN YOUR TOOLING SAVINGS INTO A NEW MACHINE!

As you increase your annual tooling spend, you'll unlock greater discounts and earn more HaasBucks to put towards a new Haas Machine.

# Winner's Circle Growth



**7K New Members this year!**

→ More than 10,000 Members Total

Winner's Circle Sign-Ups

■ E-commerce Order   ■ HFO SOLD   ● Weekly Total

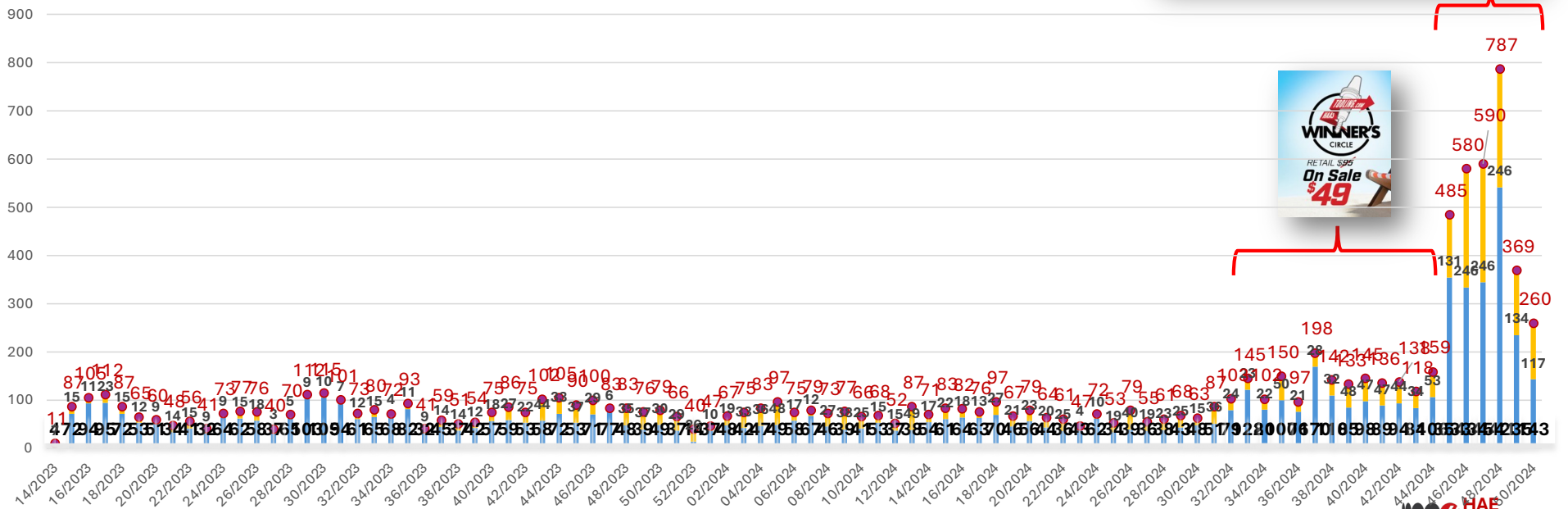
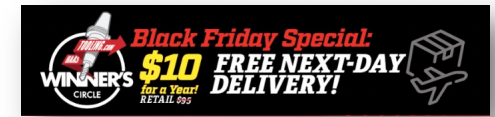

# New Haas Tooling: UMC Tombstones



- Complete line of tombstones for UMCs
  - Pyramid
  - Square
  - Hex

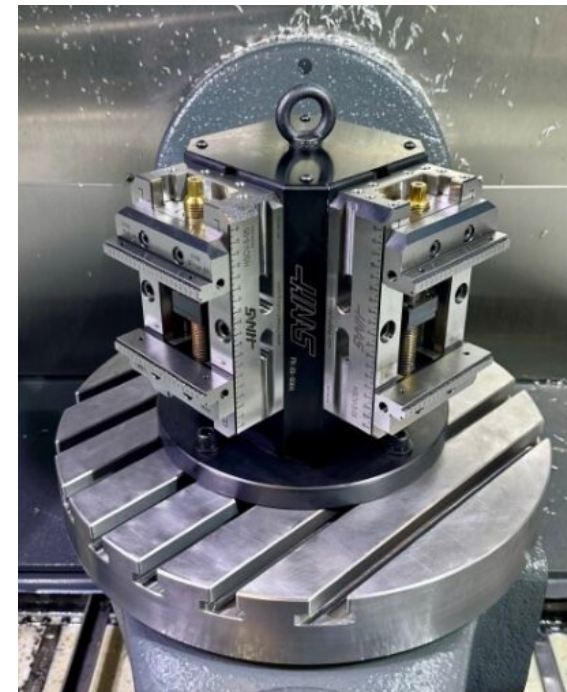
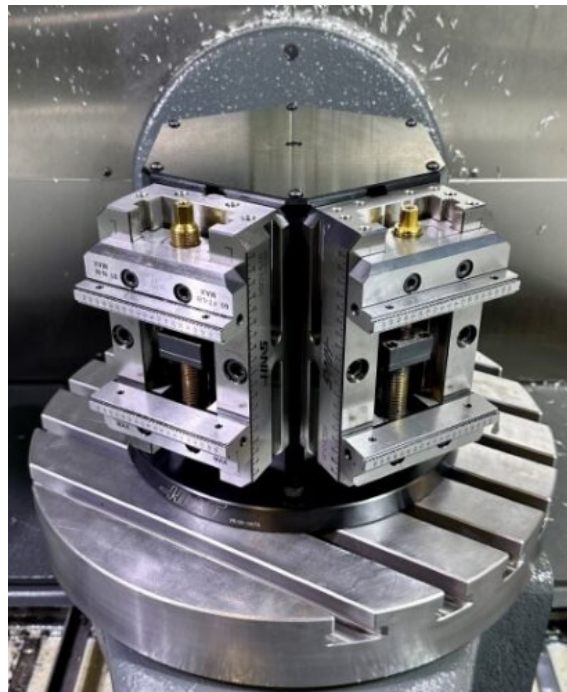

# New Haas Tooling: HMC Tombstones



- Tombstones for EC-400, EC-500, and EC-630
- Square, T-shaped, 6-sided

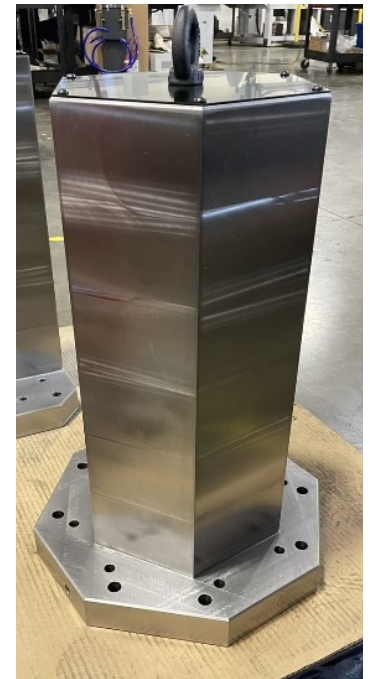
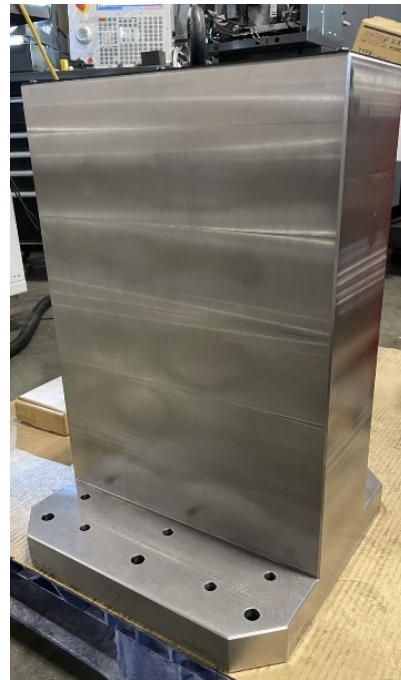

# New Haas Tooling: VF and UMC Subplates

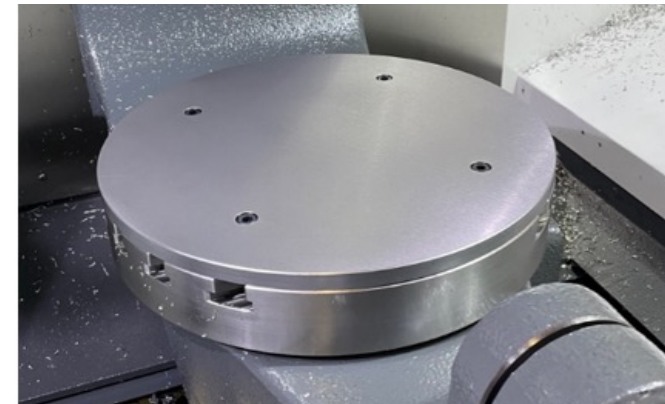
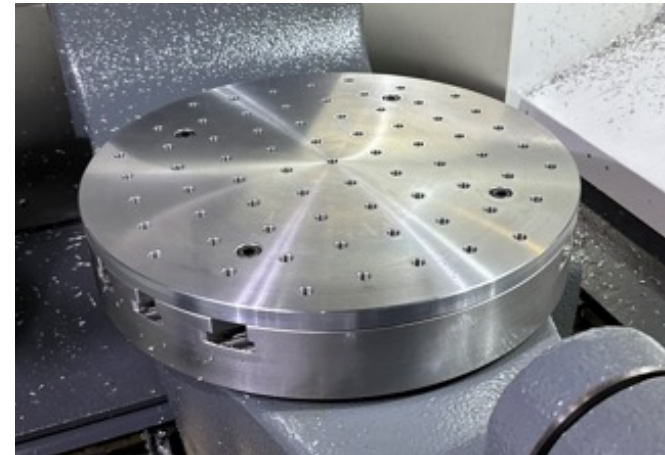
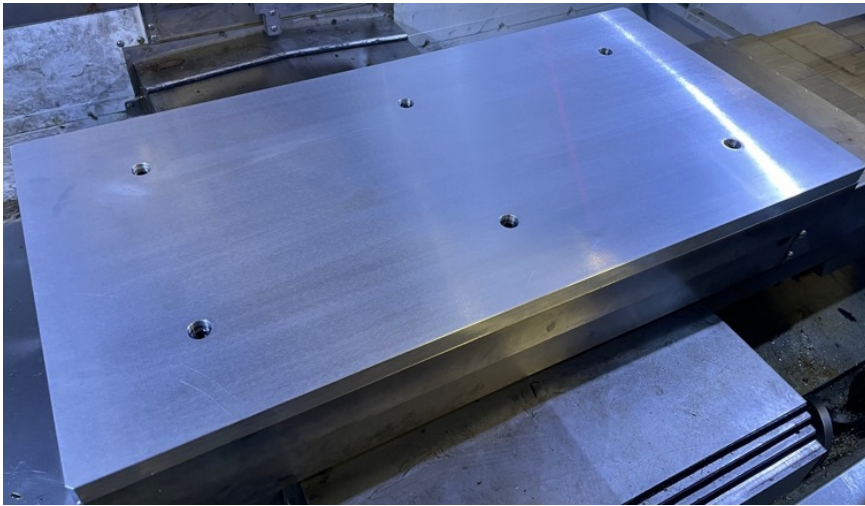

# HaasTooling.com



- In 2024, we grew the team that is supporting, building, and growing the ecommerce business
- We added a new director – Bob Biles – to lead, drive, and build the tooling business
  - He comes with extensive experience from Best Buy, Warner Brothers, Fandango, and Polaris.
  - He’s an expert in building ecommerce websites and driving growth
- Be prepared for some aggressive growth!
- I have every intention of building this into a \$500 million business world-wide

# Quick word on Service and getting our parts back

# Haas Customer Service Group



- Why we want the parts returned
  - Quickly review and determine root cause and corrective action
    - Vendor Quality
    - Design improvement
    - Poor diagnosis/troubleshooting
    - Assembly/manufacturing process
    - Customer caused
- Successes that we have seen.....
  - Reduced NFF from 27% to 9.3%
  - Reduced warranty failures
  - Average returned warranty is 14 parts per day (was 34 per day)
    - Improved designs
    - Improved vendor quality
    - Improved assembly procedures
    - Improved diagnosis/troubleshooting material

# Haas Customer Service Group



- Why we want the parts returned (Successes)

Last 90 Days - Top 20 Failed Parts with Disposition Codes

Part Number	Part Description	Total	R
93-1475B	PCOOL INSTALLATION KIT 2023	29	
93-32-3490C	I/O PCB NGC SIO-C BOARD	11	
32-5550J	AMP 30A BL SMART	10	
62-0158	PCOOL MOTOR 10RPM	9	
53-0022	PRESSURE SW 100PSI NC	9	
32-2373A	CBL AXIS MOT/ENC/BK SM MTR SIGMA-7-NGC	7	
93-4459	SERVICE KIT TILT SENSOR ASSY	7	
93-5501	AMP 30A BL SMART	7	
93-3412	SVC KIT NGC PSUP-U 3PH CCA	6	
93-4675	TURRET INDEX ASSY 12 ST BMT45 BOT	6	
93-4680	TURRET INDEX ASSY 12 ST BMT45 LT	6	
61-1045C	METAL PUSHBUTTON SWITCH PNL MNT 22MM	5	
93-4841	CABCOOL THERMAL SW 100°F SERVICE KIT	5	
61-0101	KEY SWITCH SPST 19MM 1 PULL #2007	4	
74-2000	CBL PNL MNT USB EXT .5 M 28 AWG DATA/20A	4	
83-8011A	POT 500 OHM VV QD 5W 1/4 SEALED	4	
93-2116A	DISCHARGE SOLENOID ASSEMBLY	4	3
93-32-5558E	40HP VECTOR DRIVE	4	2
22-2099	3 WAY AIR VALVE MODIFIED BIMBA	3	1
30-13432B	SPINDLE 40T INLINE 8/10/12K VMC W/DB	3	

13 of the top 20 highlighted parts have been quickly reviewed and corrective actions put in place, before it became a larger problem reducing the failures in the field

Remove the parts with corrective actions, and the quarterly failure rate is very low, single digits per quarter

The success is due to the timely return, review and disposition of failed warranty parts

The system has been active for 2.5 years in plant 1000 and it works!!

# We want our parts back



- When we get our parts that fail in warranty, our engineers look at every one and come up with corrective action.
- We will make better Haas machines.
- This will make it easier selling new Haas machines.
- This is simple.....

# Haas F1 Team Updates



- Building the Haas brand name globally

# Haas F1 Investment



- We're focused on performance, building a winning team, and promoting the Haas brand
- In 2024, we started with a New Team Principle - Ayao Komatsu - to manage and lead the team, with a goal of being very competitive
- Short-term goal is to be a top-five team!



# Haas F1 Investment



- We're investing:
  - New paddock motorhome was purchased, and will be ready for the 2025 European races
  - New drivers for 2025
  - Working on designing a new state-of-the-art Haas Race Factory in the Banbury area, UK.



# Haas F1 Technical Partnership



- We've extended our Technical Partnership with Ferrari
- We signed a technical agreement with Toyota Gazoo Racing.
- And I want a podium!



# Driver Updates



- Esteban is a proven winner!
- He has 4 podiums, including a win!
- He also has nearly 450 career points in Formula One
- We're building the team around him



# Driver Updates



- Ollie Bearman
- Ollie is a highly talented rookie
- He scored points in 2 of his 3 F1 races
  - Total of 7 points
- He has delivered under pressure as a rookie



# Haas F1 Strategy



- We're investing in the Haas F1 team
  - We're focused on building the Haas F1 team into a winner!
    - This will build the Haas brand name globally.
- And we're making big changes to the team:
  - New Team Principle – Ayao Komatsu
  - New drivers – Esteban Ocon and Ollie Bearman
  - New paddock motorhome
  - New state of the art race shop coming soon.....as early as 2027
  - And we have expanded our technical partnerships with Toyota to complement Ferrari
- We will do what it takes to build a competitive team.
  - In 2023, we finished dead last, and with all our changes, we already improved to 7th place in 2024.
  - Goal is a “top five” team, and then we see where we go from there!

# Henderson Factory Update

# Henderson Update



# Henderson Update



- 2.5 million square feet.
- Expected to be complete by 1/1/2027.
- We will be able to grow the ecommerce business to more than \$500 million in revenue annually.
- Machine tool production capacity will exceed 18,000 machines annually.

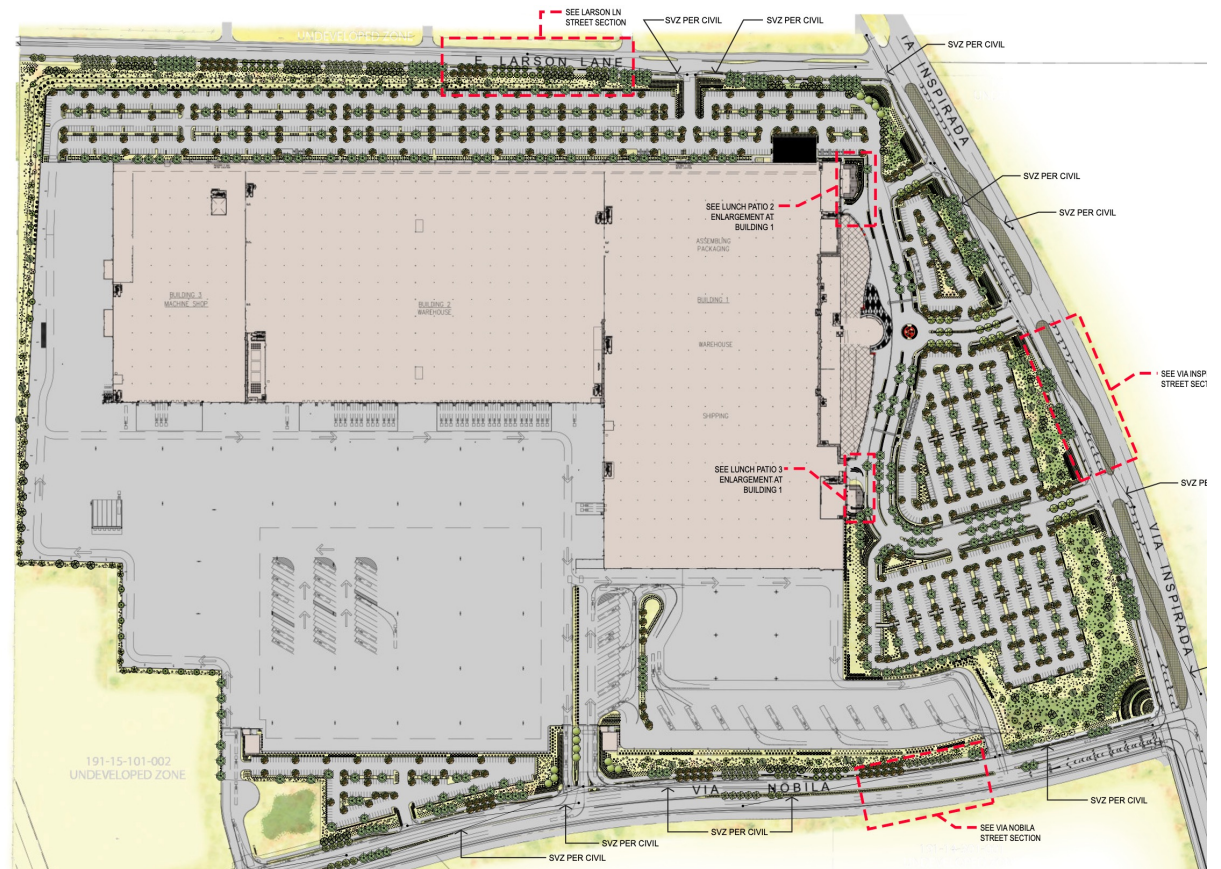

# Henderson Update



- Lobby will include a museum of Haas race cars:
  - NASCAR
  - Formula 1 cars
- We will also have a showroom capable of displaying more than 100 machines.
- And we will have an area for customer events, with capacity for 800+ guests.



# Henderson Update



Haas  
F1 Team



HAE  
HAAS AUTOMATION, INC.  
DEALER  
MEETING 25

# Henderson Update



# Henderson Update





# Henderson Update



**February 4, 2025**  
**First section of slab poured**  
**125 cement trucks**  
**1,400 cubic yards of concrete**  
**...only 209,000 cubic yards left to go!**

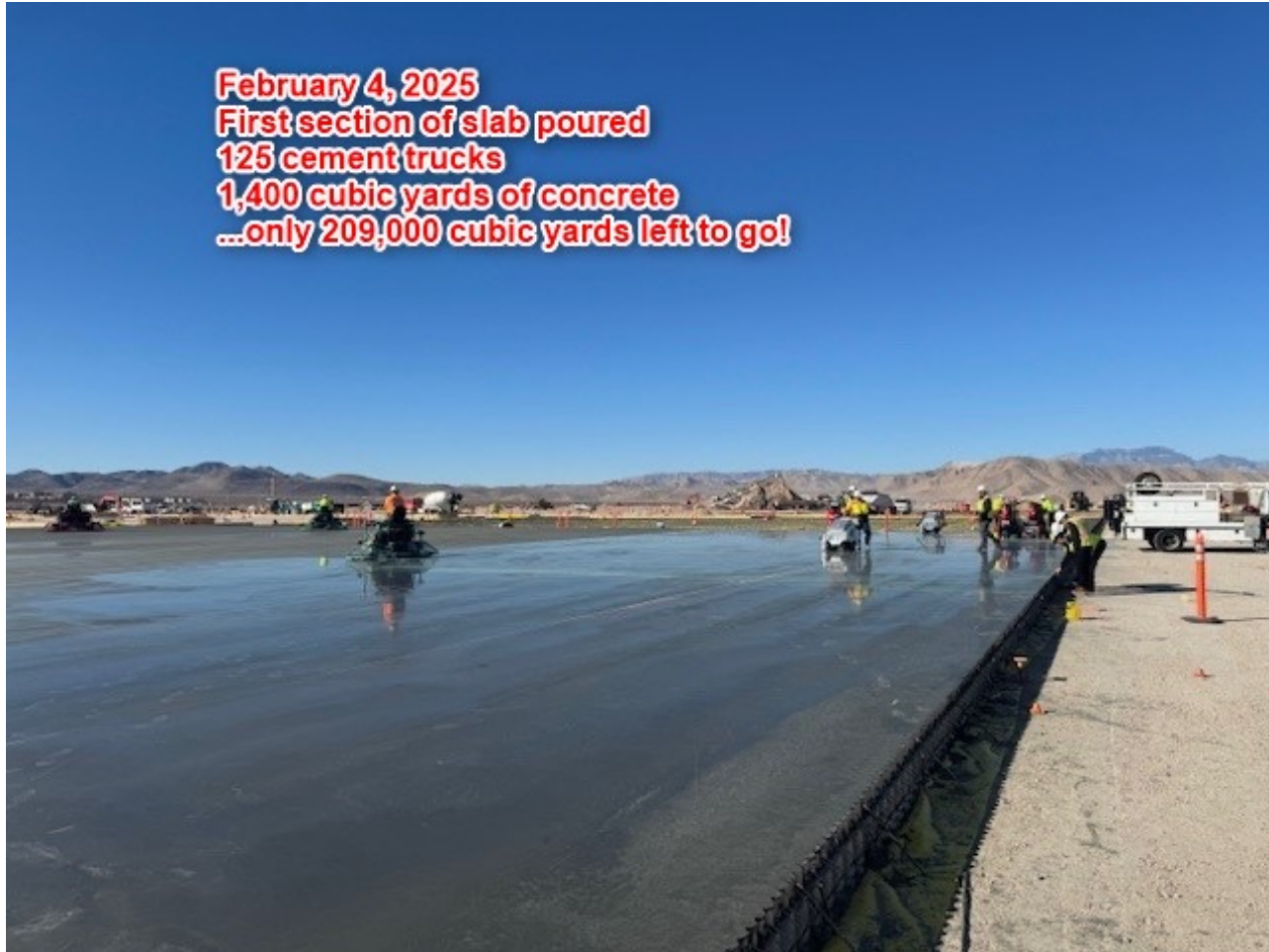

# Henderson Update



BLDG 1 SOG  
FORM/PREP

# Henderson Update



# Henderson Update



BLDG 1 SOG  
POUR #1

# Henderson Update



BLDG 1 SOG  
POUR #1

# Henderson Update



BLDG 1  
UNDER SLAB  
ELECTRICAL  
@ GL A

# Henderson Summary



- We are building one of the most “State-of-the-Art” machine tool factories in the world.
- The first production line is expected to move right after the factory is complete.....January 2027.
  - We’re currently working on the move plan.
- The new Henderson factory will allow for significant growth
  - With plenty of space to increase capacity:
    - Grow Ecommerce business to more than \$500 million annually
    - Grow the number of “Haas Designed” machines
    - Grow the Inventory “private label” Haas machines
    - And expand the “naked machine” strategy – I want to put the Haas control on as many machines as possible

**Final Word**  
***We're Growing***

# Final Word – We're Growing



- Haas is extremely focused on growth.
  - We're investing heavily in our business.
  - We're rapidly growing the product line
  - We're making significant investment in the ecommerce and tooling business
  - We're building a 2.5 million square foot building in Henderson to handle this growth. *(investment over \$400 million)*
  - And we're making big investment in the Haas F1 team to build the Haas brand name.
- Our Goal for Europe is **4000 machines sold annually by 2027**
  - 2025 = 2700 machines sold
  - 2026 = 3200 machines sold
  - 2027 = 4000 machines sold in Europe

# 4,000 Machines by 2027

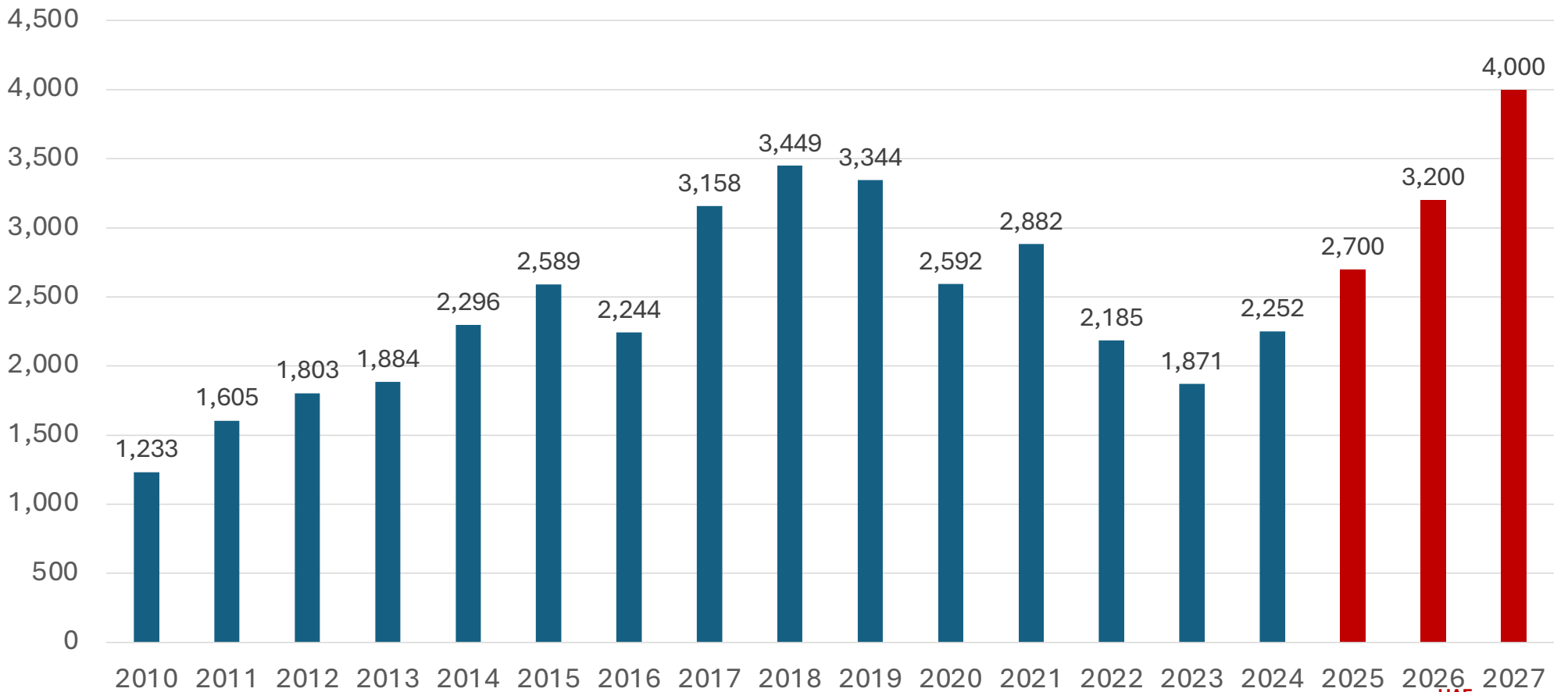

# Final Word – We're Growing



- Europe is key to our growth.
  - We'll give you everything you need to take market share and grow your business:
    - New machines (at least 25 per year going forward)
    - More things to sell: Ecommerce, Tooling and everything your customers need to run their businesses.
    - Low Financing, Aggressive promotions and Great pricing
    - And a huge brand name.....Haas F1 Team
- But let me be clear.....I need each of you to put the same effort into your business that we are.
  - You need to take market share and grow your HFO.

# Final Word – We're Growing



- And for of you that “don’t want to grow” or are “the low performers”, you need to be ready for change.....
  - I will try something new in underperforming, low market share countries/markets in 2025.
    - Here are some possible examples:
      - Put the machines on the ecommerce site and sell directly to the customer (like Tesla)
        - We sell and you service, and we give the customer choices on how to purchase Haas machines. (HFO or website)
      - Or terminate the low performing HFO’s and put 2 competing HFO’s in one territory.
      - I’m looking at all my options to grow market-share, but you need to do your part. I think a better alternative is that you embrace the new products and tooling, push your sales organizations and grow your market share.....I would prefer that over options #1 and #2.
- Thanks for helping us grow in 2024.....Europe is key to our future growth so be prepared for much more growth in 2025!

# Final Word – We're Growing



Now let's sell 2700 machines  
(or more) this year!