

# Live Demo's Showroom

- **Section 1:** Louis (Backup: xxx)
  - Machines: UMC-500 & RPL, DS-30Y & VR-9
    - Topics: RPL, CDF & Filter Conveyor, Service Panel Access, New Haas Turret Housings, Bar Chamfer Device, Broaching cycles, Double Yoke Head
    - Demo: VR-9 Cutting & Double Yoke & RPL Pallet Scheduler
- **Section 2:** Alex (Backup: xxx)
  - Machines: VF-2SSYT & HC10, DM-3, VF-4SS, ST-15Y & HRP-1
    - Topics: Drawer Cart, VF-Washdown, Multi-Stage Pump, Hole Blaster, Super Speed upgrades, Platter Options TRT, Mist Condenser
    - Demo: VF-2SSYT/Drawer Cart, DM-3 Washdown

- **Section 2: Maurice (Backup: xxx)**
  - Machines: UMC-400, VF-2SSYT & PP & UMC-750 & PP
    - Topics: 19" Pendant, Broken Tool Detection, Coolant Sanitizer, Pallet Scheduler, Stainless Covers & PP in General (PP-Ready?)
    - Demo: UMC-400 New machine, Broken Tool Detection & Coolant Sanitizer
- **Section 2: Anneleen (Backup: xxx)**
  - Machines: DC-1/40, TL-1P & SMM & C-APL
    - Topics: C-APL Door Opener Automation, Production TL-1, DC-1/40 for 40T Tool Similarity & Active Ballscrew Comp
    - Demo: DC-1/40 Tool Changer & TL-1P Demo incl hydr chuck, turret & cutting

# Showroom sections

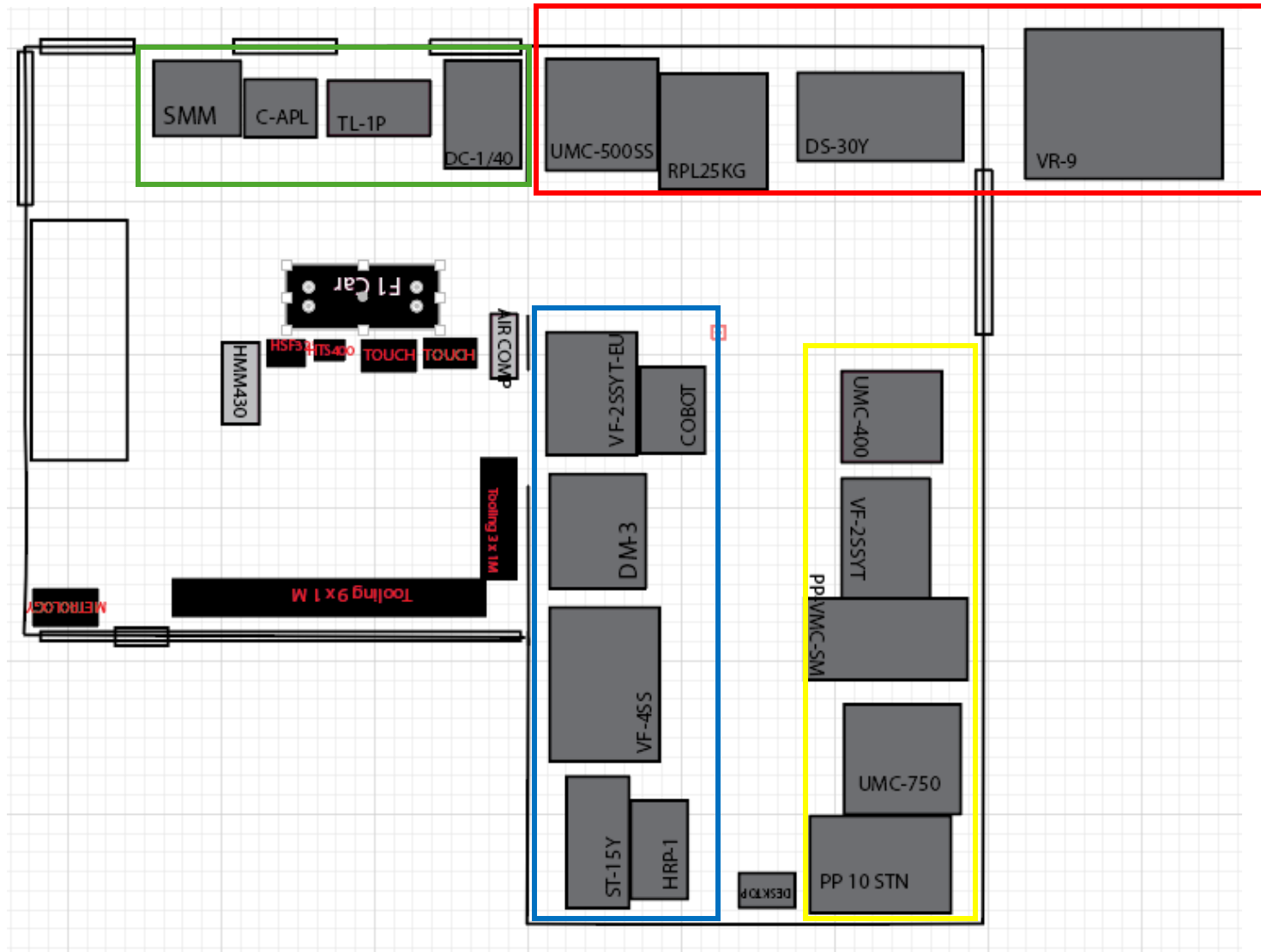

# Stainless Way Covers

- Standard on:
  - All VF, VM, VR
  - ST-40Ys
  - MM
- Coming soon:
  - Feb – CM/CL and ST-20, 30L, 40
  - Apr - ECs
  - May – ST-10/30
  - TBD – DT/DM

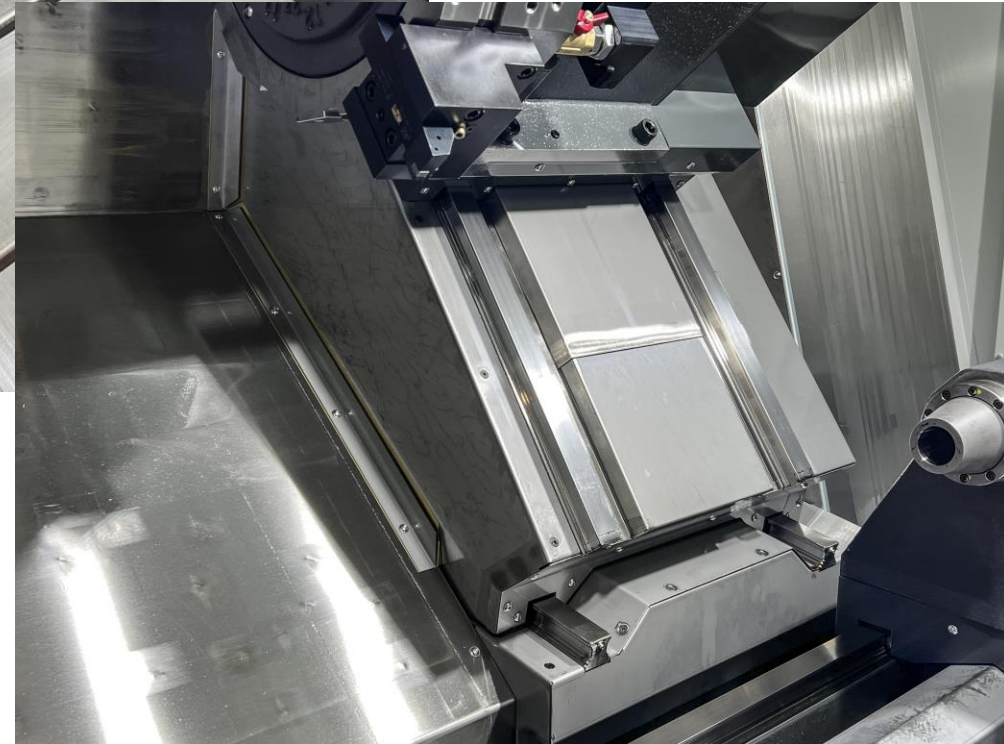

# Super Speeds Are Being Upgraded



- 2025 VF-2SS to VF-4SS (Super Speed family)
  - 1600 inch/min (63m/min) rapids
  - 18,000-rpm 40-taper & HSK63A spindle options
  - Q2-2025

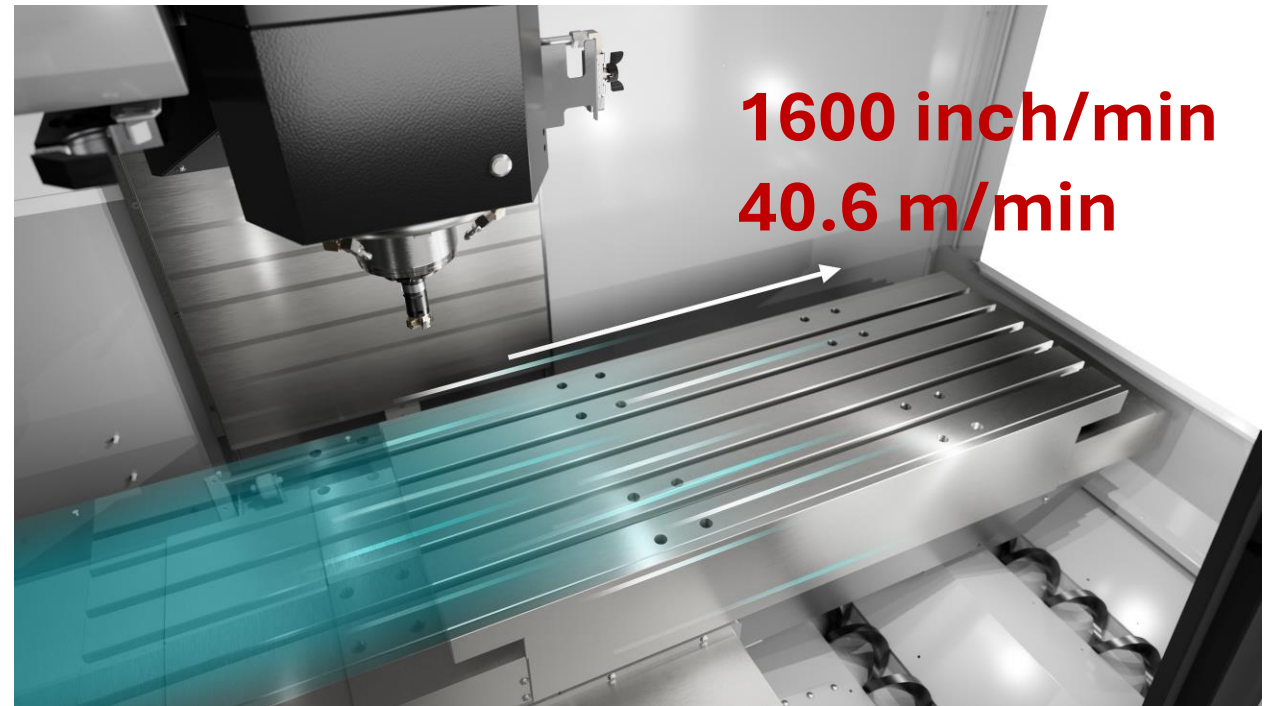
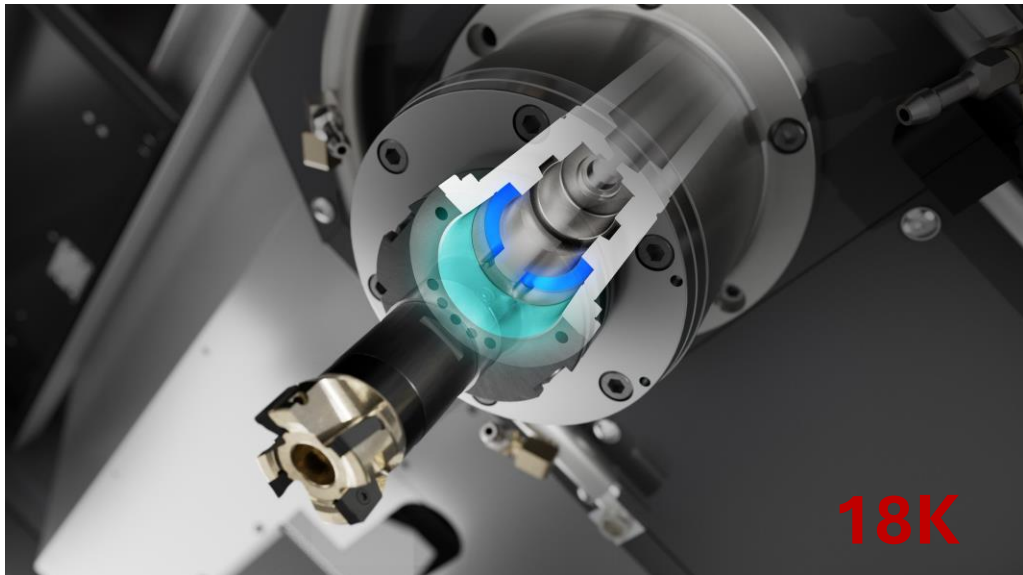

# TL-1P and TL-2P

- Production version of the Toolroom Lathes
  - Includes:
    - 3000-rpm A2-5 spindle
    - 4-station automatic tool turret
    - **New** 6.5" (165mm) chuck with hydraulic closer and HPU
  - Release March 2025
  - TL-1P - €42,995
  - TL-2P - €45,995



# DC-1 *Example of Naked Machine*

- What it comes with from supplier:
  - THK, HIWN, or Rexroth linear guides and ballscrews
  - Spindle
  - Tool changer
  - Oil lubrication system
  - Coolant tank
- What we add at the factory (Haas IP)
  - Haas CNC control
  - Spindle motor & servomotors
  - Spindle chiller
  - Solenoids and manifold for lube
  - TSC system (union and pump)
  - Flood coolant pump (VFD, HCFP)
  - Work lights
  - Auto window
  - Haas convenience package



# RPL-25KG



- **RPL-25KG**

- € 95,495
- Available for:
  - UMC-400/500/750/1000
  - VF-2/3/4/5
  - VM-2/3
- **Xx** sold
- Integrated with the Haas control for set up and pallet scheduling



# Lathe Turret Housings

## BMT65 Studs + Nuts Update

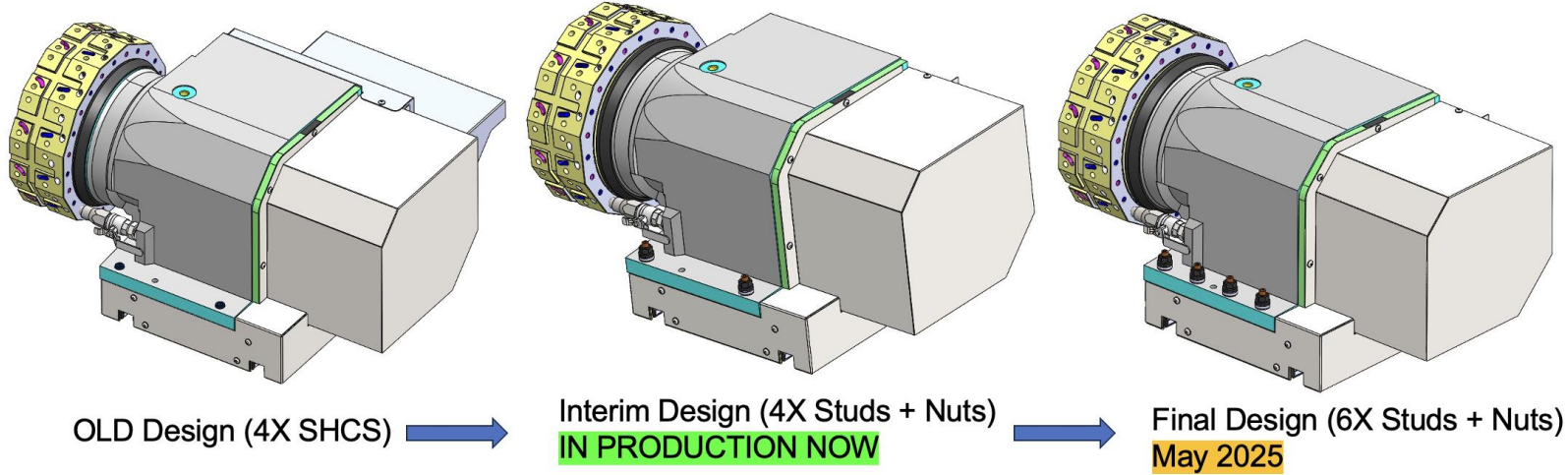

# Broken Tool Detection



- Only available for UMCs, UMC-400/SS excluded
- Uses built-in camera to visually compare tools before and after a tool change to determine if the tool was damaged during machining. Machine stops if damage is detected
- Saves money by preventing damage to tools, fixtures, work-piece or machine
- Will change to payable option on 01.03.



# Hole Blaster

- To clear chips out bored holes and threads using air-pressure
- M-Code controlled
- Requires P-COOL option
  - Adjustable position using P-COOL
- Controlled by M-Code M183/M184
- Cannot combine with PULSEJET option

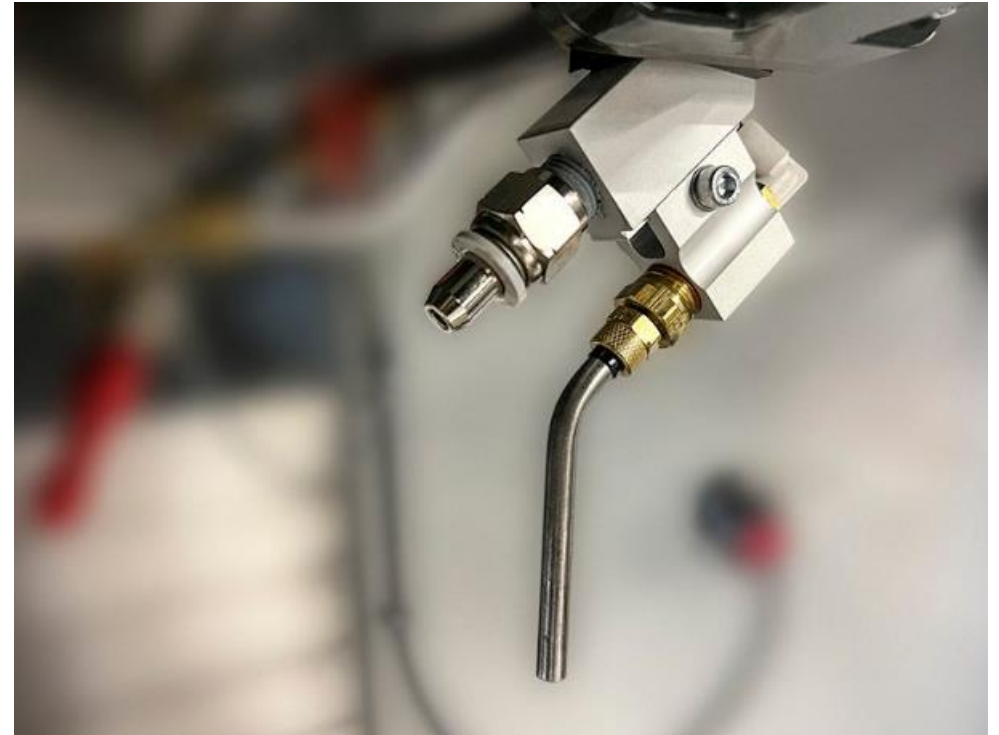

# Coolant Sanitizer



- Maintains good condition of coolant
- Reduces bacterial growth and foul odors
- Timer controlled
- Simple mounting using heavy magnet
- Field install kit available



# Active ballscrew compensation



- For large VMCs
- Replaces linear scales
- Sensors for 2 or 3 axes
- Measures ballscrew growth
- Provides dynamic/Real-Time Compensation
- Recommended for shops with big temperature variations
- Enhanced Performance for 3D surfacing incl faster response time

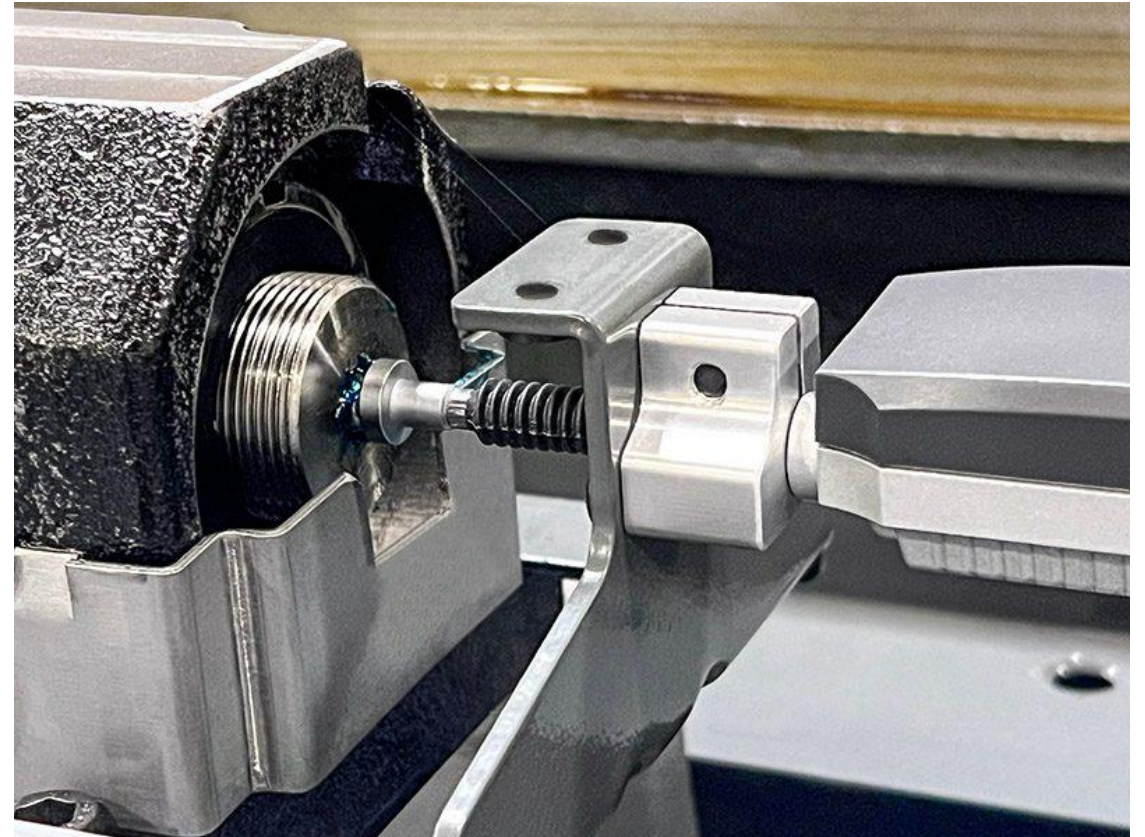

# Platter options TRTs



- Single choice, no combination
- Zero Point Kit, Auto
- Zero Point kit, Manual
- T-Slot platter
- A2-5 Platter

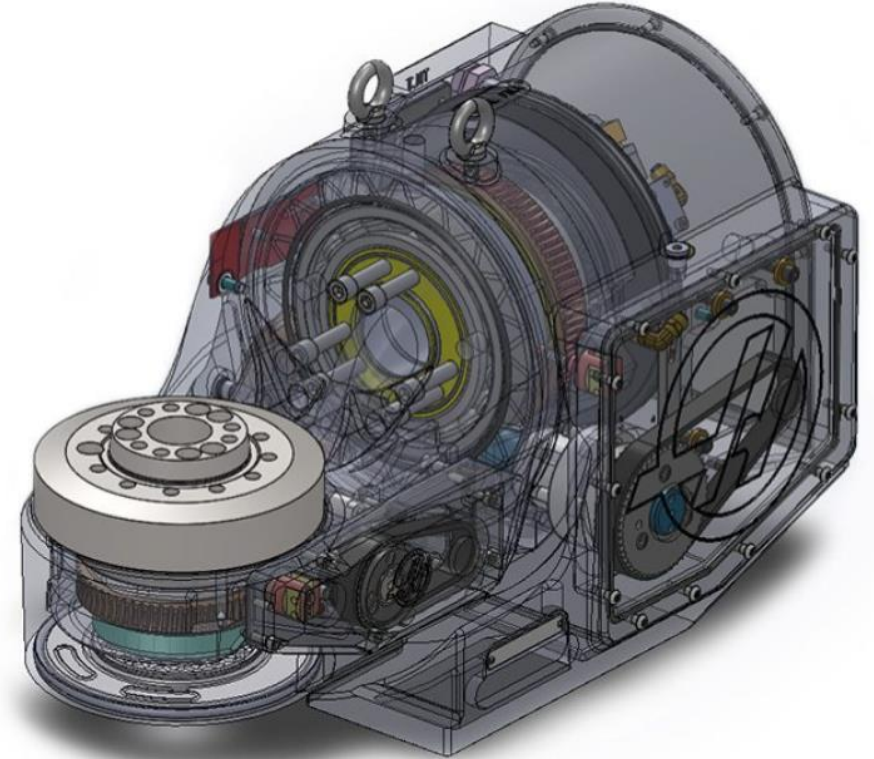
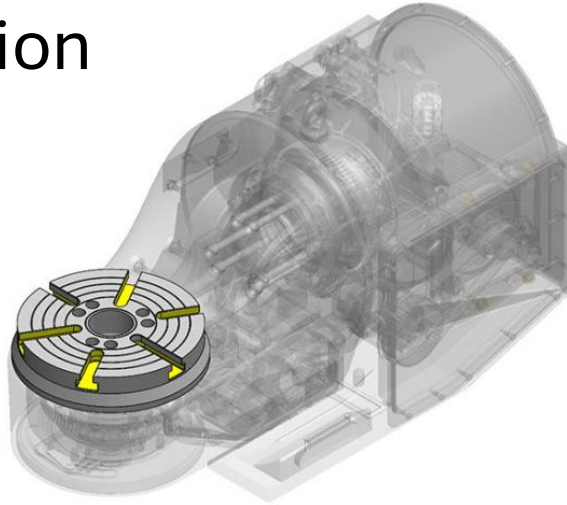

# Double Yoke Head for VRs



- New VR Head
- Haas designed VR head
- Updated design with brakes on each side
- More robust design
- Best VR head ever!

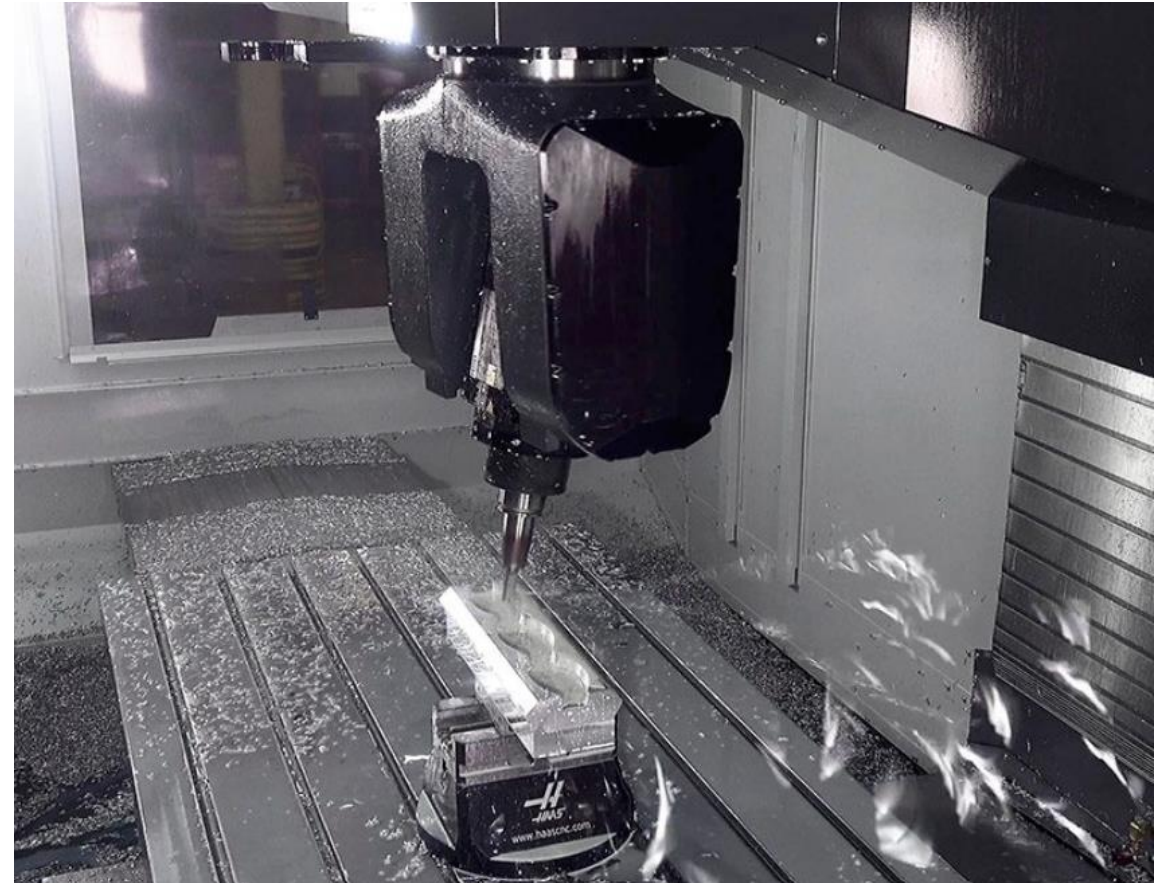

# CDF conveyor for UMCs



- Available for UMC-500/750/1000/1250/1500-DUO/SS, ECs except 1600s and VCs
- Built-In disc filtration system, heavy duty
- Activated by M-Code or from control; cycle interval interval & duration can be adjusted in user settings
- Recommended for Aluminium Applications with high chip load
- Requires 95 G coolant tank

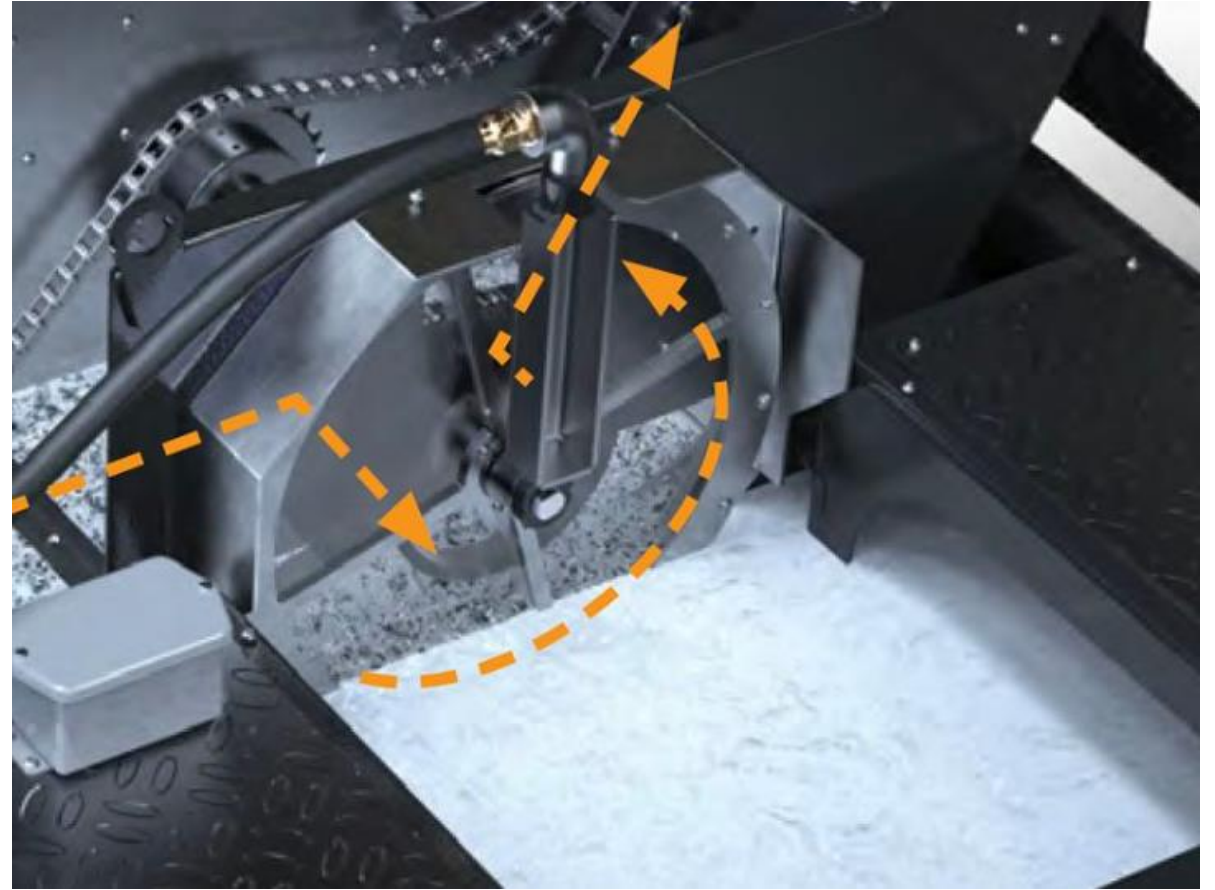

# Filter conveyors for UMCs



- Available for UMC-500/750/1000/1250/1500-DUO/SS
- More filtration than std conveyor
- Lower cost than CDF conveyor
- Recommended for aluminum machining applications that generate large quantities of smaller chips

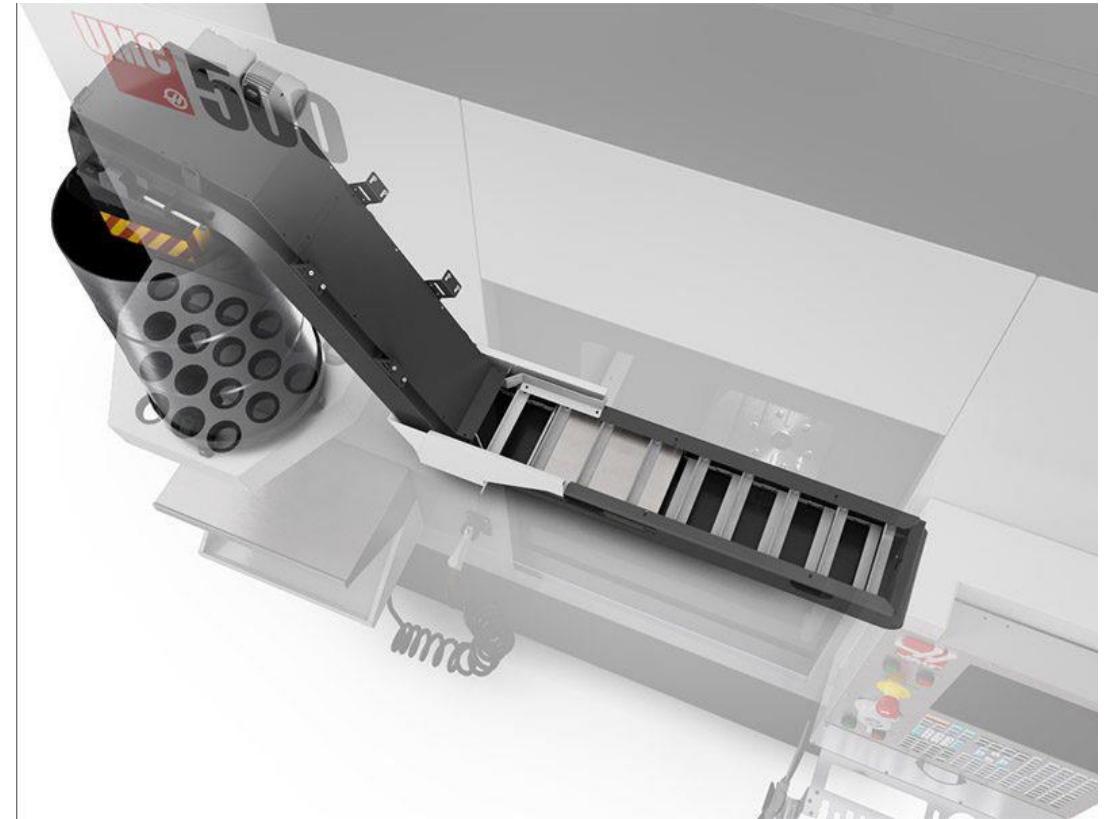

# Bar Chamfer Device

- Available for Haas Bar Feeder only
- Loading of chamfered bars is easier with or without spindle liner
- Chamfers bars at the machine
- For bars up to 51mm (2")
- Activation foot pedal included
- Field install kit available



# ST/DS Service Panel access



- New Service Panel on spindle side to simplify access to rear spindle and chuck cylinder area



# Broaching on Haas Lathes

- Broaching templates added to VPS
- Reducing cycle times and costs if no stand-alone machines are required
- Spindle Orientation & Z-Axis motion synchronized
- G156 instead of G90
- Tools & inserts available through Haas Tooling
- Available on Mills as well!
- Live demo on DS-30Y

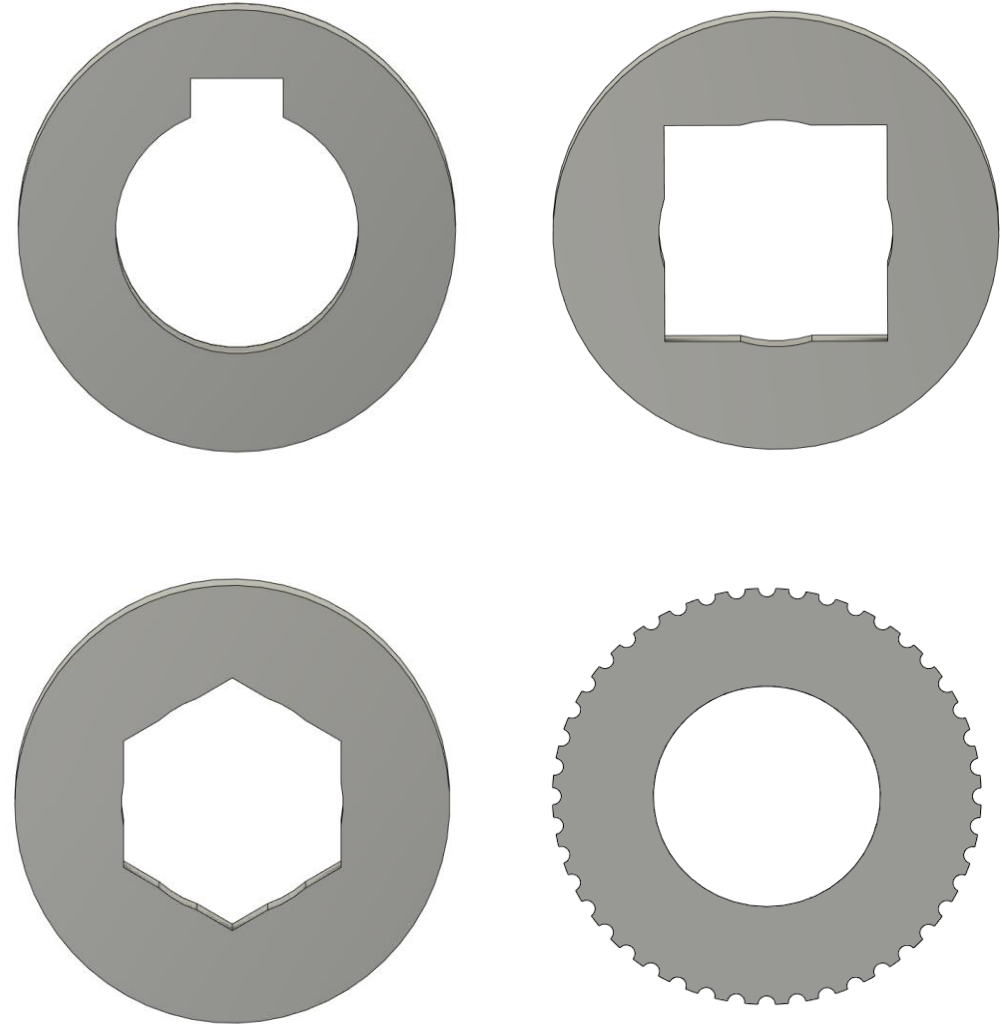

# Drawer Cart



- Drawer cart with 4 drawers
- Opens to one side only
- Roll away design
- Easy positioning as aligned by 2 fixation points are on the floor
- Opened and closed by Robot or Cobot
- Available for HC10 and HRP-1



# Single & Multi-Stage Pump

- Single-Stage Pump is a one impeller design providing reliable flow and pressure, 0,75 kW, 42 l/min @ 1.4 bar
- Multi-Stage Pump is a multi-impeller design providing larger flow and higher pressure: 1,1 kW, 53 l/min @ 3,4 bar



# Chip Washdown



- Chip Washdown will be a future standard feature
- Available for small VMCs from April 2024
- Comes with Multi-Stage Pump to achieve sufficient flow & pressure
- **Field installation will be possible?**



# Coolant Mist Condenser

- Dual mechanical filters keep the machine's enclosure free of coolant mist and smoke by condensing the mist and return the coolant into the machine enclosure
- Closed system
- Activated by M-Code, powered by the machine control
- This is not an air filtration system!
- Field installable



# Pallet Pool

- Available for UMC-500/750/1000/1250/SS
- Different sizes and amount of pallets
- Not field installable

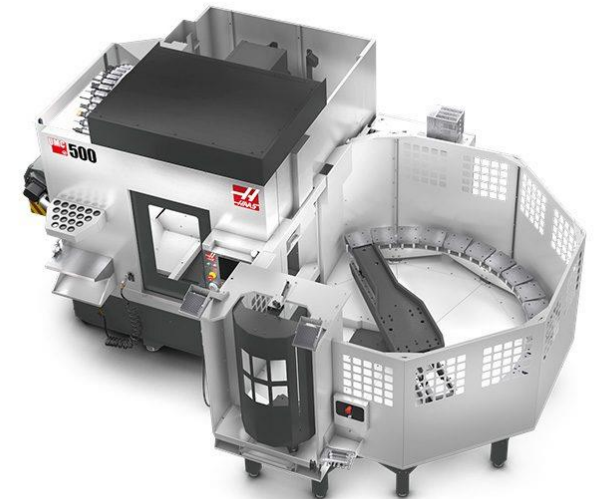

# Pallet Scheduler

- Used with pallet pools on UMCs, VMCs & EC-400
- Simple manual scheduling of pallets, integrated in the Haas control – besides the pallet scheduling in the nc program
- Pallet Pools must be ordered with the machine

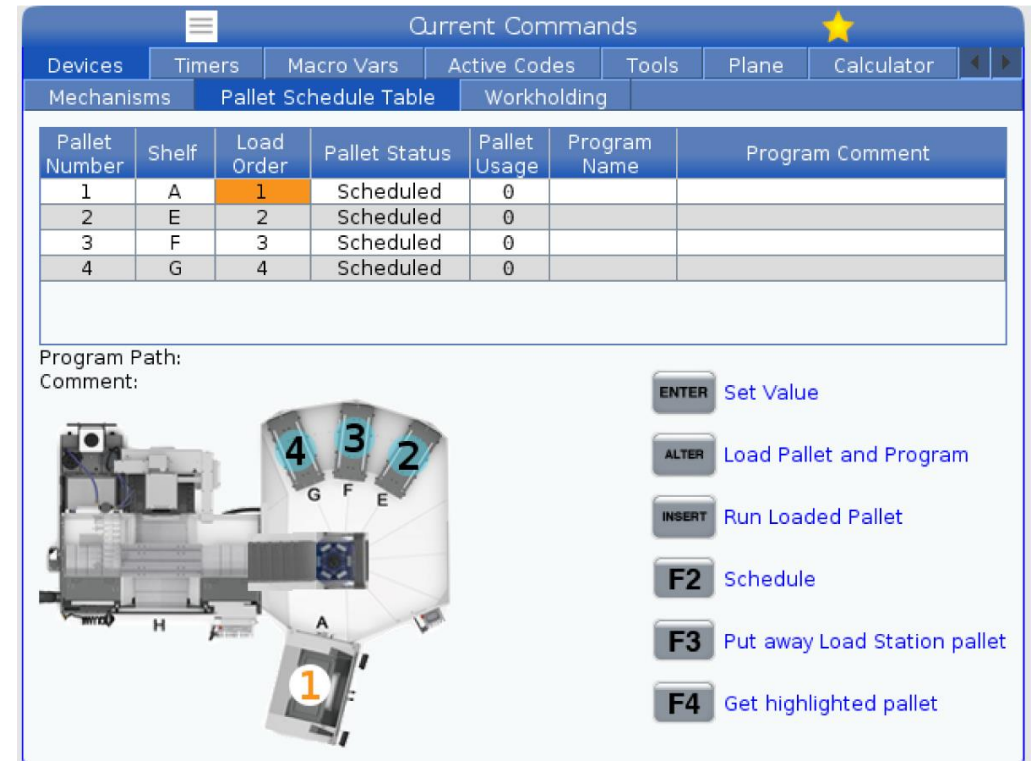

Pallet Number	Shelf	Load Order	Pallet Status	Pallet Usage	Program Name	Program Comment
1	A	1	Scheduled	0		
2	E	2	Scheduled	0		
3	F	3	Scheduled	0		
4	G	4	Scheduled	0		

Program Path:  
Comment:

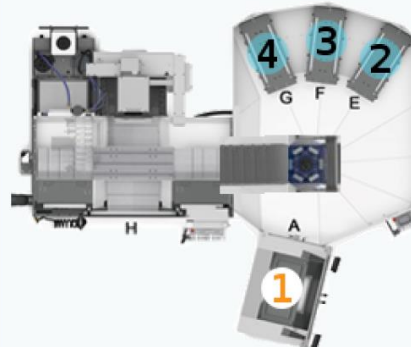

- ENTER Set Value
- ALTER Load Pallet and Program
- INSERT Run Loaded Pallet
- F2 Schedule
- F3 Put away Load Station pallet
- F4 Get highlighted pallet

# C-APL – Door Opener Automation



- The Compact APL is the door opener to bring automation to your customer
- MiniMax/SMiniMax is an unbeatable affordable automation package including options – ready to start machining
- Available for VF-2, VF-2SS, VF-2YT, VF-2SSYT, VM-2, DTs, DMs, DC-1, MM, SMM (reboot)
- Compact footprint, workpiece size 51 x 51 x 51mm, max 1,4kg
- Can be field installed, requirements apply

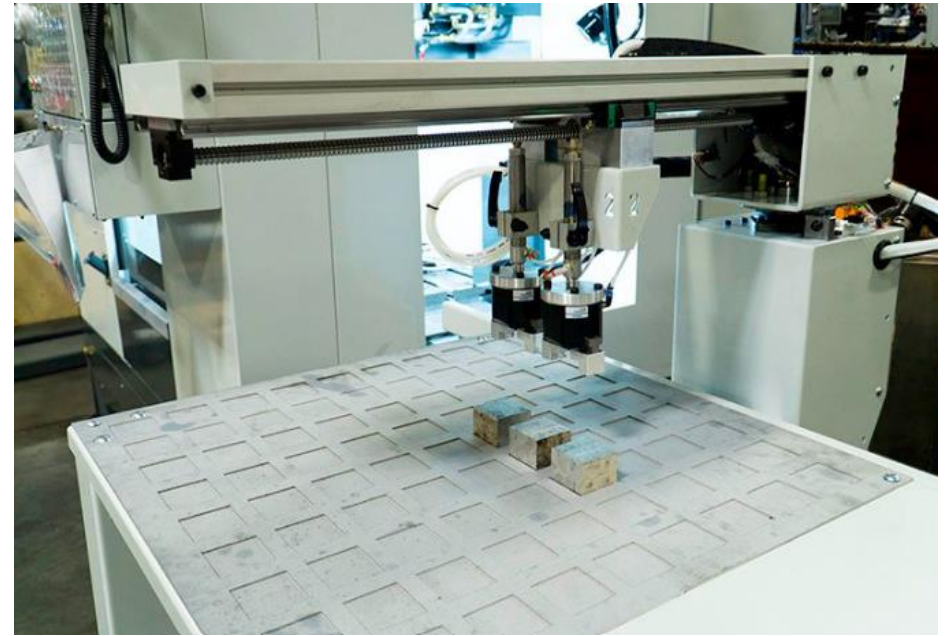

# 19" Pendant & Color Upgrade



- Phasing in, start month listed below for production
- February
  - UMC-400/500, ST-30/35, DS-30Y, SR-3015P, DT-3, DM-3, SB-28Y, ST-40LY, GM-1
- March
  - UMC-750, VF-3/4/5, VR-5, VP-5, VM-3
- April
  - VF-1/2, VM-2
- May
  - UMC-1000/1250/1500, VF-6 to VF-14, ST-10 to ST-55, VR, VM
- June
  - DT, DM, EC, GM, HDC, VC, VS
- July
  - GR, TM, TL, MM, CM, CL, Desktop, SR, Simulators

# To add???

- VR