



**SALES AND MARKETING
UPDATE**



HMAS

January/February 2025



Topics

- Products and Price List
- Video
- Tooling
- Marketing
- Did You Know...

Products and Price List Update

Jan Products and Price List Update

- VS-3-5AX release in all regions except Europe
- HKM-1 release in US/Canada/Mexico
- LT260 release in all regions
- 18K 40T and HSK-A63 spindle options added to UMC-SS, VF-SS, and VM in all regions
- STAINLESS WAY COVERS now standard on MM, large VMC, VR, VS, HDC in all regions
- QUAD AUGER-CONVEYOR option added to VF-7, VF-9 and VR-9 in all regions
- FIXTURE PLATE-UMC standard on UMC-500/500SS/750/750SS/~~1000/1000SS~~ in all regions
- Front loading DC and Minimill install kits removed from ROBOT PKG-1/7KG
- WIPS-L option removed from ST-10, 10Y, 15, 15Y, 10Y-EU, 15Y-EU

Products and Price List Update

- VS-3-5AX release in all regions except Europe



VS-3-5AX

Starting Price: US\$649,995

The Haas VS-3-5AX is a large-frame, bed-style machining center that provides large travels and 5-axis cutting capacity in a vertical spindle format. The machine features a 20,000-rpm HSK-A63 spindle and a 70+1 tool side-mount tool changer.

The Haas-built dual-axis head supports the spindle from both sides for rigidity, and has powerful brakes on both axes for accurate 3+2 machining. The rotary head provides ± 245 degrees of C-axis rotation and ± 120 degrees of B-axis tilt to reach nearly any angle.

The fully supported X-axis travels easily handle parts weighing up to 10,000 lb (4536 kg). The table surface consists of three blank tooling plates that are easily machined for custom fixturing.

NOTE: A T-slot table can be substituted for the tooling plate table at the time of order.

- Haas-built dual-axis head supports the spindle on both sides for rigidity
- ± 245 degrees of C-axis rotation and ± 120 degrees of B-axis tilt
- Powerful brakes on the B and C axes for accurate 3+2 machining
- 70+1 side-mount tool changer
- Control pendant on moveable stand for easy access
- Fully supported X-axis travel w/ 10,000 lb (4536 kg) part capacity
- 50 mm ballscrews on all axes
- 153" x 49" (3886 x 1245 mm) table, with 3 blank bolt-on tooling plates for custom fixturing

HSK-A63
TAPER

5
AXIS

20k
RPM

70+1
TOOL CAPACITY

Products and Price List Update

- HKM-1 release in US/Canada/Mexico



HKM-1 Knee Mill

Starting Price: US\$24,995



- 32.7" x 12" x 16" (831 x 305 x 406 mm) travels
- Variable-speed 4500-rpm R8 spindle
- Pneumatic power drawbar
- X-axis power feed w/clutch handles
- XY DRO
- Digital quill scale
- Coolant system w/chip tray
- Auto lube system

The Haas HKM-1 is a traditional-style knee mill with a 9" x 49" (229 x 1245 mm) table and a 4500-rpm R8 spindle.

- LT260 release in all regions



LT260 Large-Through-Hole Rotary

Starting Price: US\$14,995

Our LT Series of rotary tables provide the same features and benefits as our standard HRT Series, but offer large through-bores and a variety of platter and chuck options to handle large shafts, pipe, and other large-bore work.

Note: Requires a Haas mill with 4th-axis drive and **NGC software version 100.21.000.1130** or later for full 4th-axis operation. Stand-alone operation requires a Haas rotary control box shipped after **November 10, 2021, with software version 26.38 or newer.**

- 5.32" (135 mm) diameter through-hole
- Optional platters and chucks available
- Add large-bore 4-axis capabilities to your machine
- Easy plug-and-play connection to Haas machines

1
SPINDLES

260 mm
PLATTER SIZE

243 ft-lb
MAX TORQUE

196 °/sec
MAX SPEED

COMPARE MACHINES

EXPLORE INVENTORY [↗](#)

Available for order, with estimated delivery June 2025.

Products and Price List Update

- 18K 40T and HSK-A63 spindle options added to UMC-SS, VF-SS, and VM in all regions



18,000-rpm Inline Spindle

*Starting Price: **US\$15,995***

High-speed spindle for Super Speed mills

18k
SPEED

40
TAPER

30 hp
POWER

Inline
DRIVE

Products and Price List Update

- STAINLESS WAY COVERS now standard on MM, large VMC, VR, VS, HDC in all regions

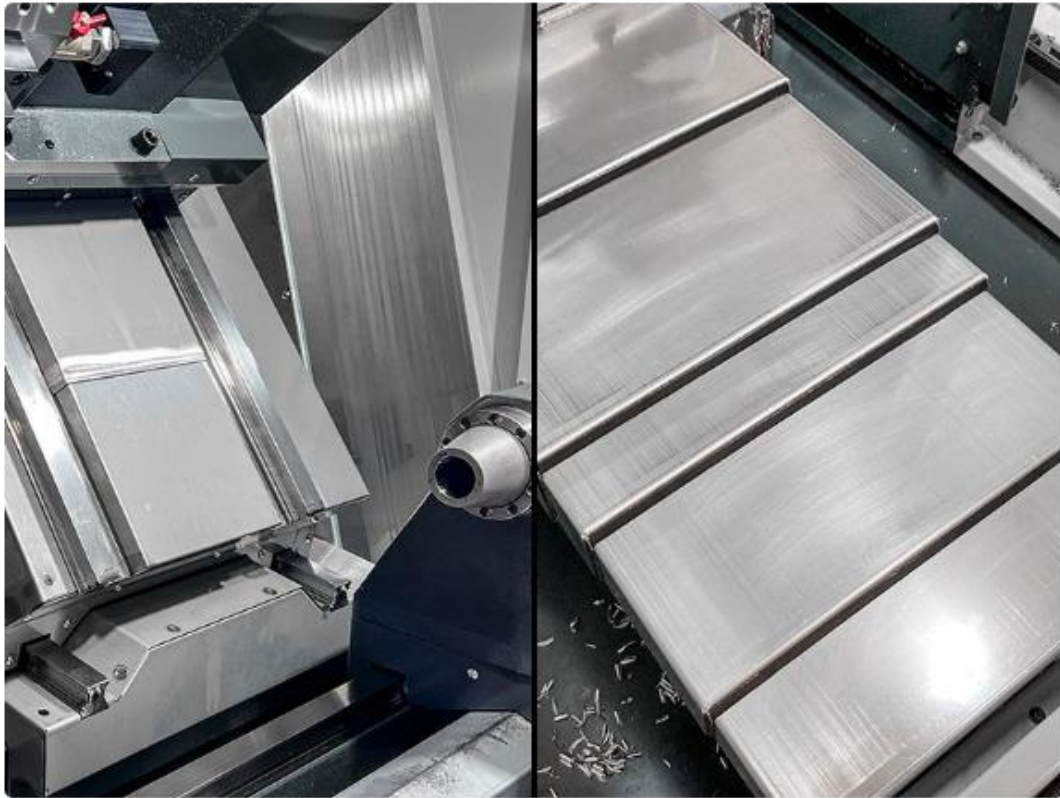

Stainless Steel Way Covers

Standard on some models

Provide excellent corrosion resistance



- Heavy-gauge 304 stainless steel construction
- Excellent corrosion resistance and strength
- Aluminum wipers for smooth operation and long life

These heavy-gauge 304 stainless steel way covers provide high strength and longevity, as well as excellent resistance to chemical corrosion and rust.

Products and Price List Update

- QUAD AUGER-CONVEYOR option added to VF-7, VF-9 and VR-9 in all regions

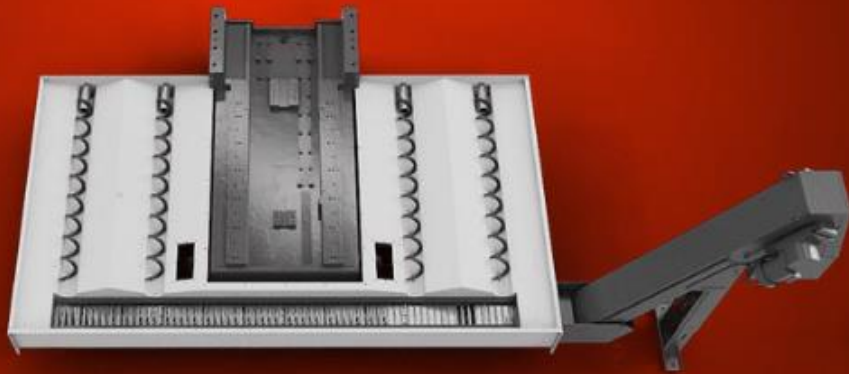

Quad-Auger System w/Conveyor

Starting Price: US\$12,595

Conveyor can discharge chips to either side

The Quad-Auger Chip Removal System with Conveyor removes chips from the machine quickly, with minimal coolant carryout. Four side augers transport the chips to the front of the pan, where they are collected by a heavy-duty steel, belt-type chip conveyor, and discharged at standard industrial barrel height.

64" Machines - \$21,395 | 84" Machines - \$24,995 | 120" Machines – Coming Soon

Products and Price List Update

- FIXTURE PLATE-UMC standard on UMC-500/500SS/750/750SS/~~1000/1000SS~~ in all regions



Rectangle Grid Fixture Plate, UMCs

Standard on some models

Mounts to the side of the trunnion

Products and Price List Update

- Front loading DC and Minimill install kits removed from ROBOT PKG-1/7KG



**7 kg Robot Front Install Kit,
Removed from
DCs and
Minimills**

Products and Price List Update

- WIPS-L option removed from ST-10, 10Y, 15, 15Y, 10Y-EU, 15Y-EU

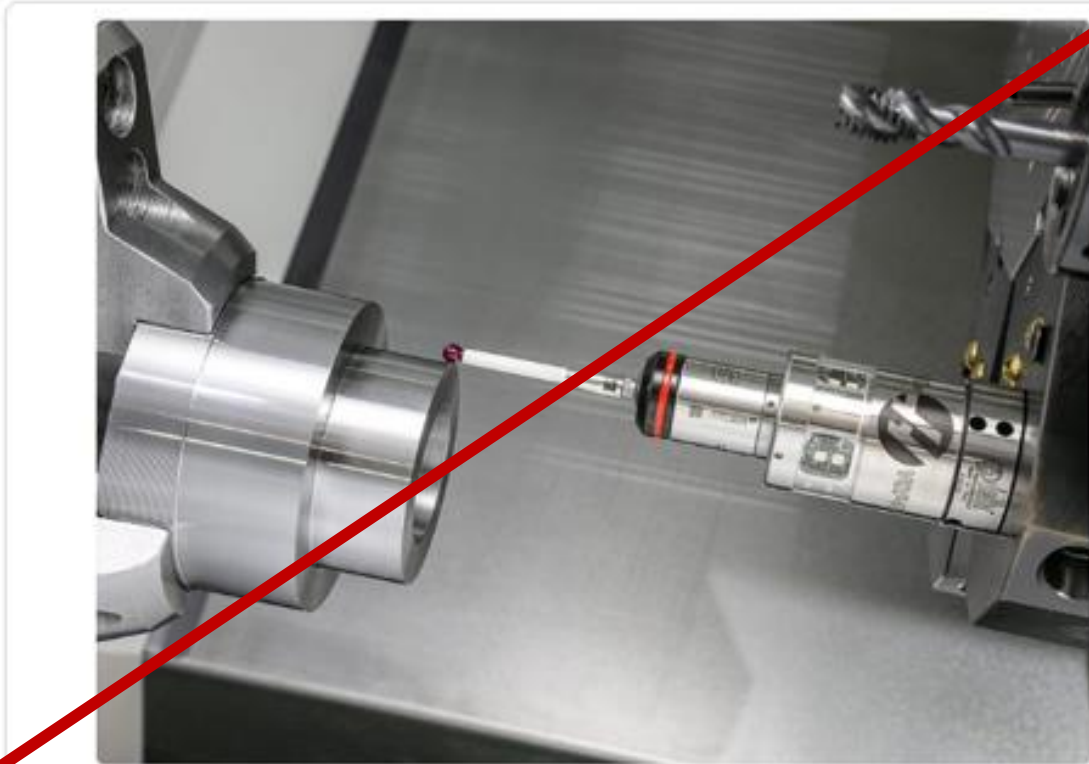

Wireless Intuitive Probing System for Lathes

Removed from
Extra Small
Lathes

Feb Products and Price List Update

- DT-3, DM-3, DC-1/40, and DC-2/40 release expanded to all regions
- DC-3/40 and DC-4/40 released for sale in all regions
- 20K-HSK-A63-HD spindle now standard on VRs in all regions
- Price increase on VRs due to HD spindle being standard
- MULTI-STAGE CLT PUMP standard on all VF, VM, UMC in all regions
- VARIABLE FLOW CLNT removed from all VF, VM, UMC in all regions due to release of MULTI-STAGE CLT PUMP
- STAINLESS WAY COVERS standard on ST-20 – 45 in all regions
- FILTER CONVEYOR option added to UMC-1250/1250SS/1500-DUO/1500SS-DUO all regions
- 64MM INSTALL KIT & 76MM INSTALL KIT options added to HAAS BAR FEEDER V2 all regions
- COBOT PKG-5KG available on CM-1 and CL-1 in all regions
- ROBOT PKG-25KG available for side loading install for medium VMC in all regions
- UMC-400/400SS: AUGER is now standard
- UMC-400/400SS: ROT SCALES-UMC has been removed from being standard

Products and Price List Update

- DT-3, DM-3, DC-1/40, and DC-2/40 release expanded to all regions



DT-3

Starting Price: US\$63,995

The DT-3 is a high-speed drill and tap machine that provides 36" (914 mm) of X-axis travel - 8" (203 mm) more than the DT-2 - while maintaining the DT-2's compact footprint. The longer X travel easily accommodates multiple fixtures, longer parts, and long extrusions, and the powerful BT30 taper inline direct-drive spindle provides 10,000 rpm, and allows high-speed rigid tapping. A high-speed, 20+1 tool changer swaps tools quickly, while 2400 ipm rapids and high acceleration rates shorten cycle times and reduce non-cutting time.

- More X-axis travel and longer table than the DT-2
- Powerful BT30 taper inline direct-drive spindle
- High-productivity machining center with a compact footprint

30
TAPER

3
AXIS

10k
RPM

20+1
TOOL CAPACITY

COMPARE MACHINES

EXPLORE INVENTORY ↗

Available for order, with estimated delivery Q2 2025.

Products and Price List Update

- DT-3, DM-3, DC-1/40, and DC-2/40 release expanded to all regions



DM-3

Starting Price: US\$73,995

The DM-3 is identical in construction and specifications to the DM-2, but provides 8" (203 mm) more X-axis travel and a longer table, while maintaining the DM-2's compact footprint. The longer X travel easily accommodates multiple fixtures, longer parts, and long extrusions, and the shop-proven 40-taper inline spindle provides 10,000 rpm, and allows high-speed rigid tapping. The machine's 18+1 tool changer, high acceleration rates, fast rapids, and impressive short tool-change times make the DM-3 an attractive high-productivity machining center.

- More X-axis travel and longer table than the DM-2
- Powerful 40-taper inline direct-drive spindle
- High-productivity machining center with a compact footprint

40
TAPER

3
AXIS

10k
RPM

18+1
TOOL CAPACITY



COMPARE MACHINES

EXPLORE INVENTORY [↗](#)

Available for order, with estimated delivery Q2 2025.

Products and Price List Update

- DT-3, DM-3, DC-1/40, and DC-2/40 release expanded to all regions

DC-1/40 Drill Center

Starting Price: US\$49,995

The DC-1/40 is a traditional-style drill/tap machine with a 10,000-rpm 40-taper spindle and high-speed turret-style tool changer to minimize cut-to-cut times and shorten cycle times. Choose the optional 12,000-rpm or 15,000-rpm spindle to cut production times even further.

The compact footprint and rear chip discharge of the DC-1/40 allow machines to be placed side-by-side to maximize floor space, and provide easy side access for automation systems. The machine's one-piece, extra-wide base provides stable support for heavier parts and fixtures, and the wide-stance triangulated column increases overall rigidity.

NOTE: The DC-1/40 has 14 mm T-slots. T-slot hardware and toe clamp kits are available from HaasTooling.com.

- 10,000-rpm 40-taper spindle (12,000-rpm or 15,000-rpm available)
- High-speed turret-style tool changer, 20 tools
- Available auto window for easy automation
- Rear chip discharge with front chip flush
- Compact footprint

40
TAPER

3
AXIS

10k
RPM

20
TOOL CAPACITY



Products and Price List Update

- DT-3, DM-3, DC-1/40, and DC-2/40 release expanded to all regions



DC-2/40 Drill Center

Starting Price: US\$64,995

The DC-2/40 is a larger version of our traditional-style drill/tap machine that offers more X and Y travel and a larger table to accommodate bigger parts, multiple vises, or high-density setups. The machine is equipped with a 10,000-rpm 40-taper spindle and high-speed turret-style tool changer to minimize cut-to-cut times and shorten cycle times. Choose the optional 12,000-rpm or 15000-rpm spindle to cut production times even further.

The rear chip discharge of the DC-2/40 allows machines to be placed side-by-side to maximize floor space, and provides easy side access for automation systems. The machine's one-piece, extra-wide base provides stable support for heavier parts and fixtures, and the wide-stance triangulated column increases overall rigidity.

- More travel and larger table for bigger parts and high-density setups
- 10,000-rpm 40-taper spindle (12,000-rpm or 15,000-rpm available)
- High-speed turret-style tool changer, 20 tools
- Available auto window for easy automation
- Rear chip discharge with front chip flush



40
TAPER

3
AXIS

10k
RPM

20
TOOL CAPACITY

COMPARE MACHINES

EXPLORE INVENTORY [↗](#)

Available for order, with estimated delivery Q2 2025. 

Products and Price List Update

- DC-3/40 and DC-4/40 released for sale in all regions



DC-3/40 Drill Center

Starting Price: US\$99,995

The DC-3/40 is a gantry-style drill/tap machine with 78.7" (2000 mm) of X-axis travel to accommodate long, narrow parts or high-density production setups. The machine's gantry-style spindle head travels in the X and Z axes, while the table travels in Y, and is fully supported along its length to handle heavier loads.

The machine is equipped with a 10,000-rpm 40-taper spindle and high-speed turret-style tool changer to minimize cut-to-cut times and shorten cycle times. Choose the optional 12,000-rpm or 15000-rpm spindle to cut production times even further.

Well suited to the construction, automotive, and aviation industries, the DC-3/40 can process parts more than 6.5 ft (2 m) long and 1.6 ft (0.5 m) wide, in a variety of shapes and profiles, such as long extrusions, steel channel, angle iron, and pipe.

- 78.7" (2000 mm) X travel to handle long parts and high-density setups
- 10,000-rpm 40-taper spindle (12,000-rpm or 15,000-rpm available)
- High-speed turret-style tool changer, 20 tools
- Rear chip discharge with front chip flush

40
TAPER

3
AXIS

10k
RPM

20
TOOL CAPACITY

COMPARE MACHINES

EXPLORE INVENTORY ↗

Available for order, with estimated delivery Q3 2025.

Products and Price List Update

- DC-3/40 and DC-4/40 released for sale in all regions



DC-4/40 Drill Center

Starting Price: US\$109,995

The DC-4/40 is a gantry-style drill/tap machine with 98.4" (2500 mm) of X-axis travel to accommodate long, narrow parts or high-density production setups. The machine's gantry-style spindle head travels in the X and Z axes, while the table travels in Y, and is fully supported along its length to handle heavier loads.

The machine is equipped with a 10,000-rpm 40-taper spindle and high-speed turret-style tool changer to minimize cut-to-cut times and shorten cycle times. Choose the optional 12,000-rpm or 15000-rpm spindle to cut production times even further.

Well suited to the construction, automotive, and aviation industries, the DC-4/40 can process parts more than 8 ft (2.5 m) long and 1.6 ft (0.5 m) wide, in a variety of shapes and profiles, such as long extrusions, steel channel, angle iron, and pipe.

- 98.4" (2500 mm) X travel to handle long parts and high-density setups
- 10,000-rpm 40-taper spindle (12,000-rpm or 15,000-rpm available)
- High-speed turret-style tool changer, 20 tools
- Rear chip discharge with front chip flush

40 TAPER	/	3 AXIS	/	10k RPM	/	20 TOOL CAPACITY
-------------	---	-----------	---	------------	---	---------------------

COMPARE MACHINES	EXPLORE INVENTORY ↗
------------------	---------------------

Available for order, with estimated delivery Q3 2025.

Products and Price List Update

- 20K-HSK-A63-HD spindle now standard on VRs in all regions
- Price increase on VRs due to HD spindle being standard

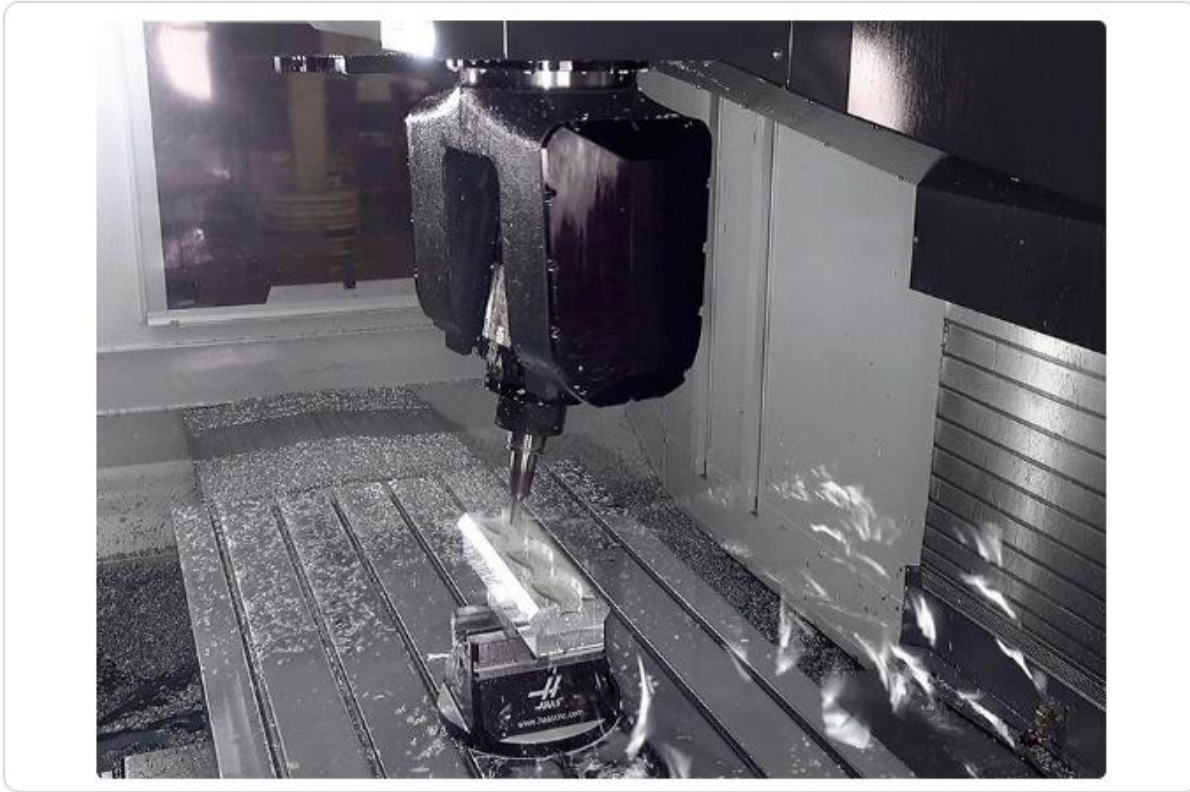

20,000-rpm Dual-Support Spindle, HSK-A63

Standard on some models

Standard spindle for the VR Series

20k
SPEED

HSK-A63
TAPER

29 hp
POWER

Integral Motor
DRIVE

Products and Price List Update

- MULTI-STAGE CLT PUMP standard on all VF, VM, UMC in all regions



Multi-Stage Coolant Pump

Standard on some models

More flow, more pressure, less noise

- VARIABLE FLOW CLNT removed from all VF, VM, UMC in all regions due to release of MULTI-STAGE CLT PUMP

Products and Price List Update

- MULTI-STAGE CLT PUMP standard on all VF, VM, UMC in all regions



OVERVIEW



SERVICE DOCUMENTS



AVAILABLE ON THESE MACHINES

Our multi-stage coolant pump uses a series of stacked impellers to provide more flow and higher pressure than the single-stage coolant pump, while offering much quieter operation.

- ✓ Quieter than the single-stage pump
- ✓ Built-in filter screen on the pickup tube
- ✓ 1.5 hp (1.1 kW) pump
- ✓ Higher flow and pressure

	SAE	METRIC
Power	1.5 hp	1.1 kW
Flow Rate 60Hz	16 gpm @ 70 psi	61 L/min @ 4.8 bar
Pressure 60Hz (outlet)	70 psi	4.8 bar
Pressure 60Hz (spindle)	40 psi	2.8 bar
Deadhead Pressure 60Hz	130 psi	9 bar
Flow Rate 50Hz	14 gpm @ 50 psi	53 L/min @ 3.4 bar
Pressure 50Hz (outlet)	50 psi	3.4 bar
Pressure 50Hz (spindle)	30 psi	2.1 bar
Deadhead Pressure 50Hz	95 psi	6.6 bar

Products and Price List Update

- STAINLESS WAY COVERS standard on ST-20 – 45 in all regions

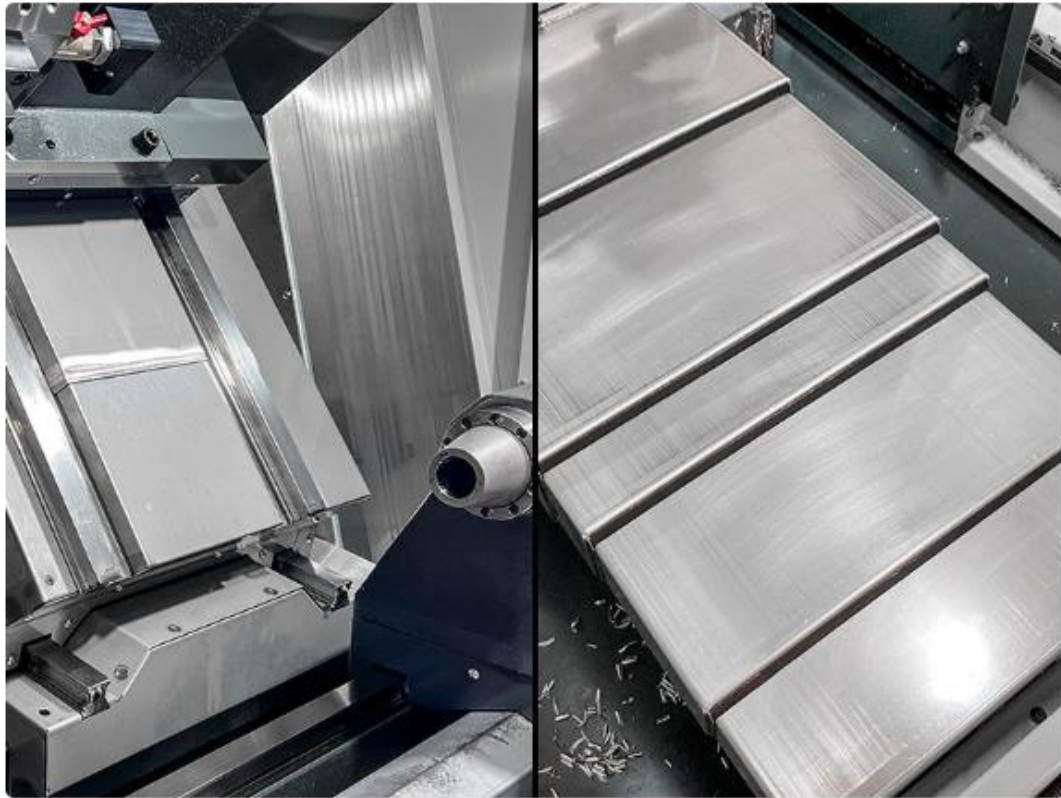

Stainless Steel Way Covers

Standard on some models

Provide excellent corrosion resistance



- Heavy-gauge 304 stainless steel construction
- Excellent corrosion resistance and strength
- Aluminum wipers for smooth operation and long life

These heavy-gauge 304 stainless steel way covers provide high strength and longevity, as well as excellent resistance to chemical corrosion and rust.

Products and Price List Update

- FILTER CONVEYOR option added to UMC-1250/1250SS/1500-DUO/1500SS-DUO all regions

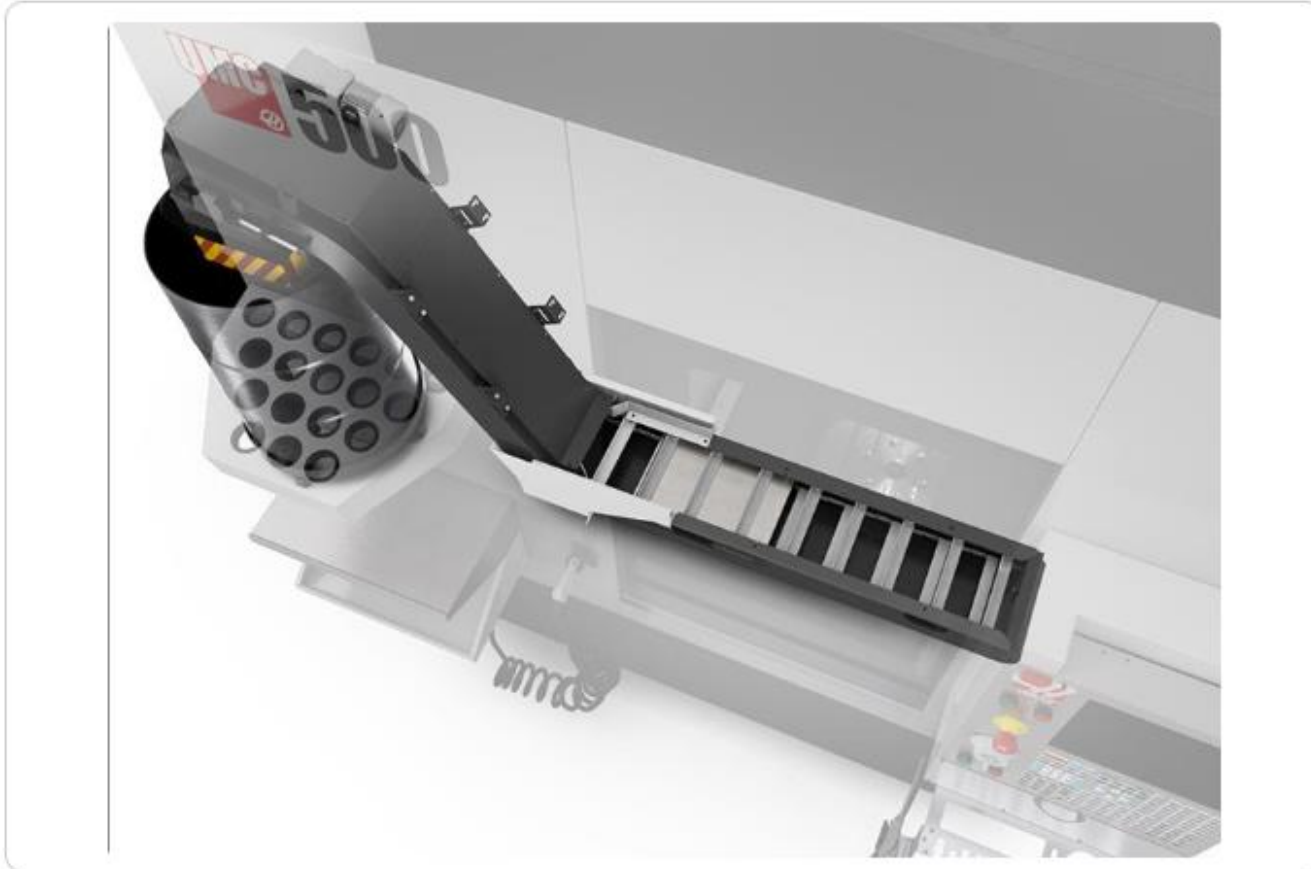

Filtration Conveyor

*Starting Price: **US\$11,995***

Reduces chip accumulation in the tank

Products and Price List Update

- 64MM INSTALL KIT & 76MM INSTALL KIT options added to HAAS BAR FEEDER V2 all regions



Bar Feeder Installation Kit, 64 mm

Starting Price: US\$1,595

Everything you need to install your Haas Bar Feeder



Bar Feeder Installation Kit, 76 mm

Starting Price: US\$1,595

Everything you need to install your Haas Bar Feeder

Products and Price List Update

- COBOT PKG-5KG available on CM-1 and CL-1 in all regions

Cobot 5 Front Door Integration Kit, CM-1

Standard on some models

Load parts through the front door



Cobot 5 Front Door Integration Kit, CL-1

Standard on some models

Load parts through the front door



Products and Price List Update

- ROBOT PKG-25KG available for side loading install for medium VMC in all regions



Robot-25kg Side Install Kit, Medium VMCs

Standard on some models

Everything you need to install your Haas
Robot Package

Products and Price List Update

- UMC-400/400SS: AUGER is now standard



Chip Auger

Standard on some models

Automatically remove chips from the machine

Products and Price List Update

- UMC-400/400SS: ROT SCALES-UMC has been removed from being standard

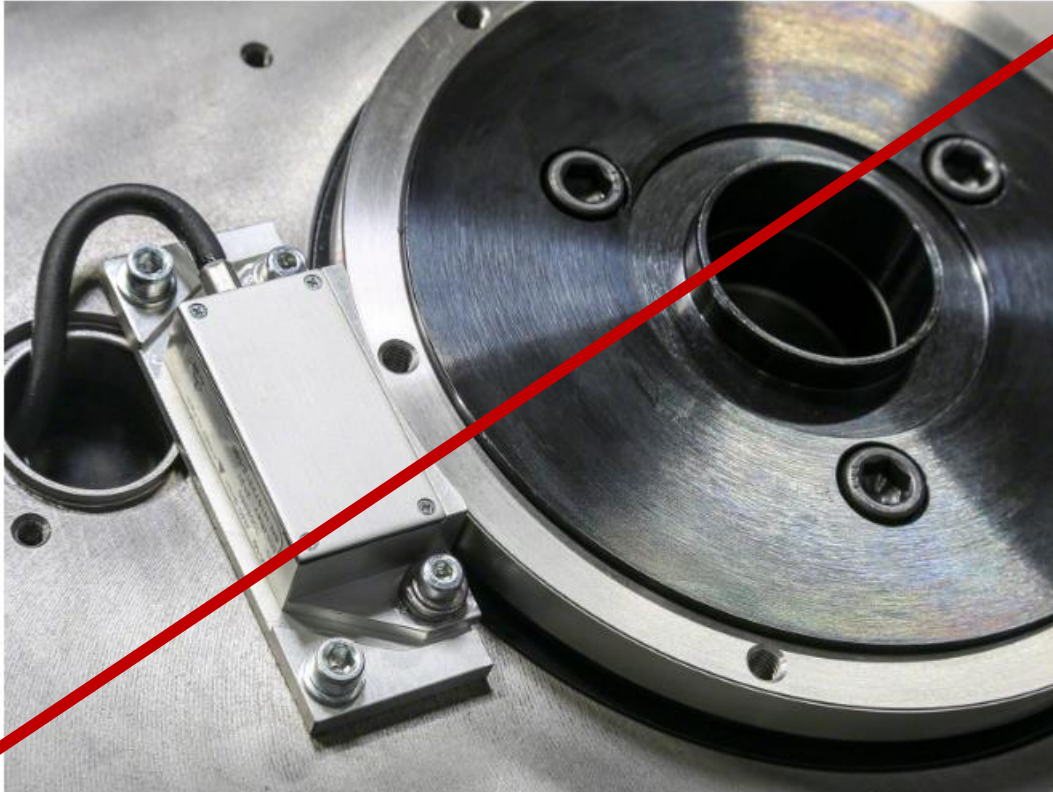

Rotary Scales

Standard on some models

~~Increases the accuracy of the rotary axes~~



Video Update

Video Update

Recently Released Videos

- New V-Groove Hard Jaws on HaasTooling.com - <https://www.youtube.com/watch?v=FsTy3vLBnB0>
- New Probing Templates and In-Process Inspection on Your Haas Mill - https://www.youtube.com/watch?v=2eP_o-WC9Mw
- Customer Spotlight - Advanced Product Design - <https://www.youtube.com/watch?v=-n3M-qB0mjE>
- Use Advanced Tool Management to Establish Backup Tools for Long Run Jobs - <https://www.youtube.com/watch?v=9bInkN7Z7Y8>
- Haas' New Shop Floor CMM - The HMM430 Coordinate Measuring Machine - <https://www.youtube.com/watch?v=ewE37cnMEIM>
- Tapping steel with a 1/2" NPT Pipe Tap on Haas VF-4SS - <https://www.youtube.com/watch?v=xmCBPDHVH2w>

Video Update

Recently Released Videos

- New V-Groove Hard Jaws on HaasTooling.com - <https://www.youtube.com/watch?v=FsTy3vLBnB0>

HaasTooling Video

- Easy Tool
- Makes Life Easier
- Saves Time & Money



Video Update

Recently Released Videos

- New Probing Templates and In-Process Inspection on Your Haas Mill - https://www.youtube.com/watch?v=2eP_o-WC9Mw

Product Highlights Video

- In-Process Inspection
- John demonstrates how easy it is to use VPS Templates
- Detailed Explanation
- Downloadable
- Software 100.24.000.1120 or later

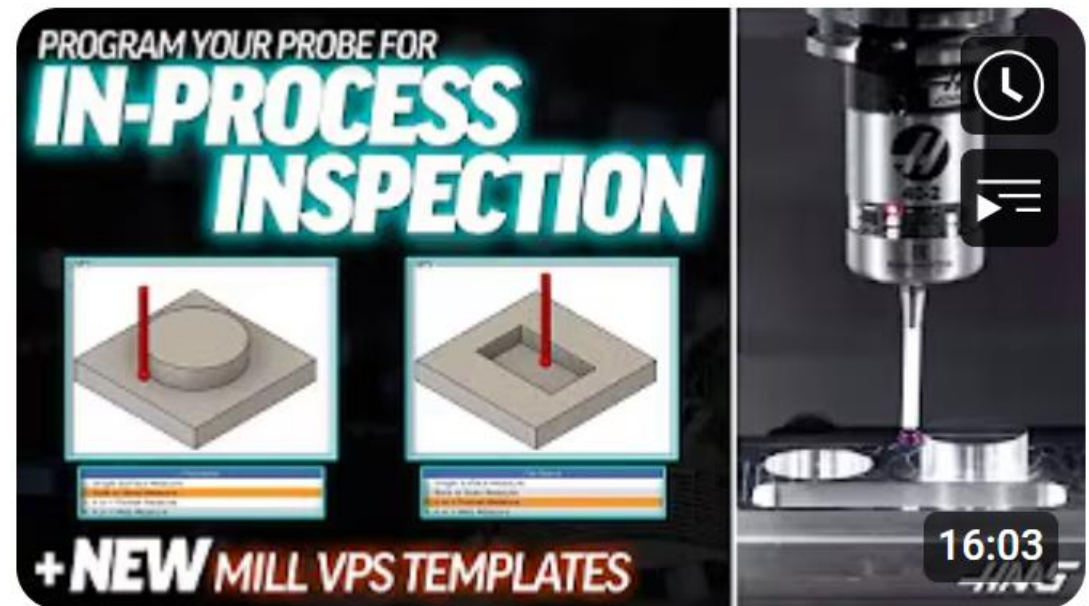

Video Update

Recently Released Videos

- Customer Spotlight - Advanced Product Design - <https://www.youtube.com/watch?v=-n3M-qB0mjE>

Customer Spotlight Video

- Advanced Product Design
- UMC-500SS Pallet Pool
- Combine Operations
- 11 Pallets
- Group Multiple Parts
- 15 hour runtime
- “Flawless Integration”
- “I’ll never buy another machine without Automation”



Video Update

Recently Released Videos

- Use Advanced Tool Management to Establish Backup Tools for Long Run Jobs - <https://www.youtube.com/watch?v=9bInkN7Z7Y8>

Product Highlights Video

- Alex Demonstrates the use of Advanced Tool Management
- Standard Feature with Haas
- Absolute Must for Automation
- Monitor Tool Wear, Life Expectancy & Tool Usage
- Easily Manage Tool Groups
- Step by Step – How To...



Video Update

Recently Released Videos

- Haas' New Shop Floor CMM - The HMM430 Coordinate Measuring Machine - <https://www.youtube.com/watch?v=ewE37cnMEIM>

Product Highlights Video

- Anton Demonstrates features and Functionality of HMM430
- Shop Floor CMM
- Renishaw Components
- CappsDMIS Software
- Great Introductory Video



Video Update

Recently Released Videos

- Tapping steel with a 1/2" NPT Pipe Tap on Haas VF-4SS - <https://www.youtube.com/watch?v=xmCBPDHVH2w>

Cutting Demo Video

- Shows Rigid Tapping of 1/2" NPT in Alloy Steel
- Effortless Cut
- Repeatable
- Also shown in Aluminum
- VF 40 Taper Machines



Tooling Update



WINNER'S CIRCLE Update

Over 10,000 Members so far...

Only \$49 – 50% off the already reduced price

Tooling Update, Global Except Europe & China



Tooling Fixture Subplates

9 items



Turning Holder Reduction Sleeves / Bushings

92 items

+178 Items



Indexable Drill Bodies

66 items

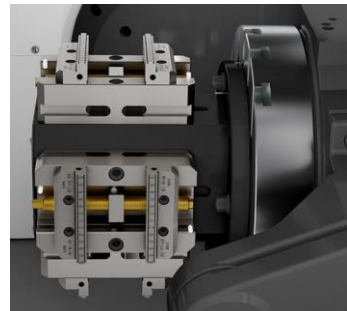

Hydraulic Milling Chucks & Collets

33 items



Vise Jaws

64 items



- Laser Marker Filters
- Tooling Fixtures (Steel & Aluminum)
- Reduction Sleeves (Inch & Metric)
- R8 Toolholder kits
- Indexable Drill Bodies (Inch & Metric)
- TriLock® Vise Cluster Tower
- Self-Centering Vise Block Kit
- BT30 Hydraulic Milling Chucks
- V-Groove jaws



WINNER'S CIRCLE Update

Over 10,000 Members so far...

Only €49 – 50% off the already reduced price

HAE - Tooling Update



Tool Bags

1 items



Indexable Drill Bodies

32 items



+66 Items



Turning Holder Reduction Sleeves / Bushings

39 items

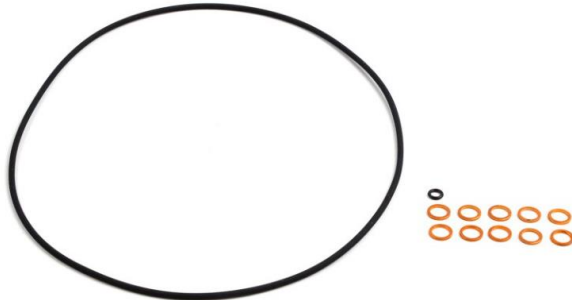

Fixture Clamps

85 items



- Shop Tool Backpack
- Indexable Drills Bodies & Inserts
- Electric Toolholder Taper Cleaner Kits
- Reduction Sleeves
- Surface Roughness Gauges
- Self-Center Vise Seal Kits
- Rail Fixture & Kits

Marketing Update



Kickstart the New Year
Automate Your Haas Machine!

Automate



Haas Tooling's Best Deals
Are Here!

HAAS TOOLING.COM

Winter Mega Sale

Up To **50% Off**

Sign up for **WINNER'S CIRCLE \$49** (\$95)
FREE NEXT-DAY DELIVERY FOR 1-YEAR!

SHOP HAAS TOOLING

Marketing Update

- Marketing Efforts
 - Financing Programs
 - In-Stock Machine Sale
- Haas Tooling Inventory Sale

NO MODEL RESTRICTIONS

UP TO
6-MONTH SKIP
AVAILABLE

NO PRE-PAYMENT PENALTIES EVER!

INSANE FINANCING FOR YOUR NEXT HAAS CNC							
DOWN PAYMENT	CHOOSE YOUR TERM						
	12-MONTHS	24-MONTHS	36-MONTHS	48-MONTHS	60-MONTHS	72-MONTHS	84-MONTHS
10% DOWN	0.00%	0.00%	0.00%	0.99%	1.49%	1.99%	2.49%
20% DOWN	0.00%	0.00%	0.00%	0.00%	0.99%	1.49%	1.99%
30% DOWN	0.00%	0.00%	0.00%	0.00%	0.00%	0.99%	1.49%
20% DOWN + 3-MO SKIP	0.00%	0.49%	0.99%	1.49%	1.99%	2.49%	2.99%
20% DOWN + 6-MO SKIP	0.99%	1.49%	1.99%	2.49%	2.99%	3.49%	3.99%

APPLY FOR FINANCING TODAY

* Financing Terms, Conditions, and Exceptions: References are to an implied interest rate under a conditional sales contract. Interest accrues during the skip period. Down payment, rate, and terms of financing are dependent upon credit approval. Eligible businesses should have three or more years of operation under current ownership, **U.S. and Canada only**. All programs are 10% - 30% down. Must put a minimum of 20% down to get no payments for 6 months. **Certain equipment (e.g., stand-alone Rotaries, Shop Equipment, Bar Feeders, etc.) are subject to different rates, terms, and down-payment requirements, unless financed with a machine.** No prepayment penalty on any program. Not responsible for misprints or typographical errors. Offer valid on new machine orders placed from **February 1 through February 28, 2025.**

Marketing Tools

View Edit Track Devel

*** All images are clickable ***



MARKETING CAMPAIGNS

[HAAS TOOLING HOME PAGE](#)

[Haas Tooling Promo page](#)

[How to redeem Online Tooling Promos](#)

[2025 AVAILABLE DIGITAL MARKETING CAMPAIGNS and MODEL GUIDES, PDFs, CATALOGS](#)

*Check Marketing Campaign page for info about HFO Demo Day.

[Tooling Kits Explained \(08/PCK/EK\)](#)

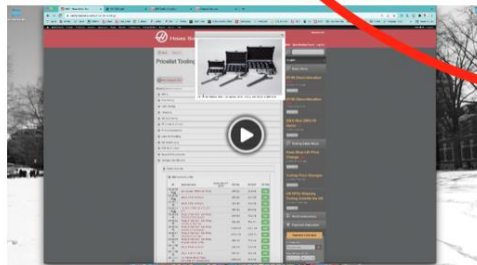

HFO DEMO DAY *2025!

DEMO DAY 2025 THEME: "More Than..."

We are promoting this upcoming Demo Day with the theme of: **"More Than..."**

- ✓ **More than CNC,** ✓ **More than Tooling,** ✓ **More than Workholding,**
- ✓ **More than Shop Support,** ✓ **More than Robots,** ✓ **More than Automation,**
- ✓ **More than Rotary,** ✓ **More than...**

HFOs will be presenting these "More than..." topics, but they can choose which specific machines and Haas Tooling items to display that best suit their markets and customers. Customers should walk away from Demo Day with a clear understanding that Haas and their HFO are about more than just machines and are their supplier of choice for all their machine shop needs.

Updated Graphics coming soon!

Fill out the survey below to start the process of getting marketing materials created for your Demo Day. You must submit the survey a minimum of 2 months before your event. *(If you have a non-Demo Day event, please fill out the survey for HFO EVENTS.)*

Date updated: Jan 2025

[DEMO DAY SURVEY](#)

[LANDING PAGE TEMPLATE](#)

A survey will be created to collect T-shirt orders. If your Demo Day is scheduled before the survey is available, please email HFOEmailSupport@HaasCNC.com.

Email ↓



PROMOTIONS

NEW PRODUCTS

GENERAL & MACHINE

TOOLING

PDFS AND BROCHURES

NEW PRODUCT MARKETING CAMPAIGNS

- ✓ Band Saw
- ✓ Air Compressor
- ✓ Laser Marker
- ✓ CMM
- ✓ Surface Grinder

- ✓ Knee Mill
- ✓ UMC-400/SS
- ✓ DMs/DTs
- ✓ TL-P
- ✓ ST-40 Updates (short/long/Y-axis)

- ✓ DC Series
- ✓ SR-3015 and SR-3015P Sheet Router
- ✓ Robotic Pallet Loader
- ✓ Mini Max

Band Saw

Haas HAB-3232 Automatic Band Saw (Shop Equipment)

Boost shop productivity with the Haas HAB-3232 Automatic Bandsaw. Built for precision and efficiency, it cuts a range of metals smoothly and can handle multiple lengths per cycle with bar-stacking capability. The intuitive control panel offers easy operation, while AI Mode or manual adjustments let you optimize feedrate settings.

Date updated: Nov 8, 2024

LANDING PAGE

YOUTUBE VIDEO

Single Page PDF

SALES SHEET

Email



Air Compressors

Haas Air Compressors (Fixed- and Variable-Speed)

The Haas 3-in-1 rotary-screw air compressor package delivers clean, dry air in a compact, cost-effective design, featuring a 15 hp motor producing up to 52.8 cfm at 145 psi—ideal for running up to 10 Haas machines with extra capacity for tools. Available in fixed or variable speed, it includes a 12-month warranty, turbo cooling, heavy-duty filters, and is built for continuous operation.

Date updated: Nov 8, 2024

LANDING PAGE

YOUTUBE VIDEO

Single Page PDF

SALES SHEET

Email



Laser Marker

Haas HL50E Fiber Laser Marking Machine

The Haas HL50E is a fully enclosed, infrared fiber laser marking machine that uses advanced photonics and fiber optic technology for precise and efficient laser marking. Its design provides a straighter, more accurate laser beam suitable for marking various metals and some non-metallic materials, making it ideal for diverse manufacturing applications.

Date updated: Nov 8, 2024

LANDING PAGE

YOUTUBE VIDEO

Single Page PDF

SALES SHEET

Email



HAE Marketing Update



Kickstart the New Year
Automate Your Haas Machine!

Automate

Haas
Fit Team



Haas Tooling's Best Deals
Are Here!

HAAS TOOLING.COM

Winter Mega Sale

Up To **50% Off**

Sign up for **WINNER'S CIRCLE €49** (€95)

FREE EXPRESS DELIVERY FOR 1-YEAR!

SHOP HAAS TOOLING

Did You Know...

Did You Know...

VS-3-5AX

70+1 SMTC
Shipping Height

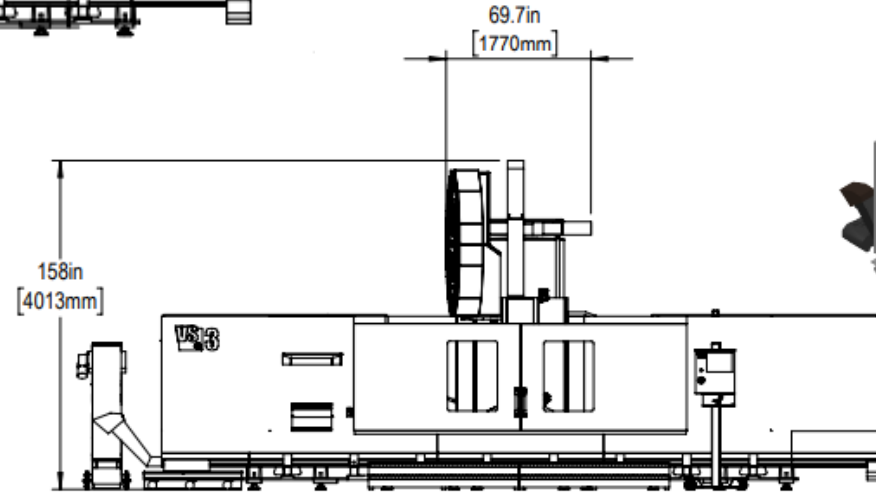
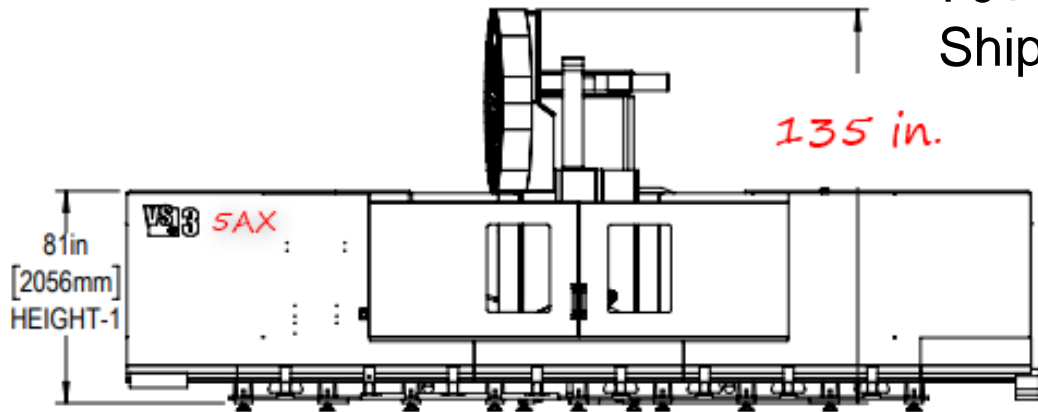

70+1 SMTC
Operational Height

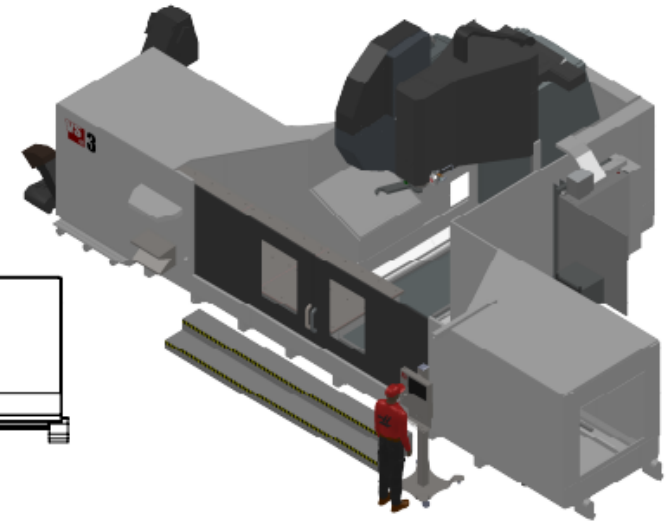

- Factory Training Dates for 2025
 - March 19/20
 - June 18/19
 - September 10/11
 - December 3/4

Please email Scott Gasich directly with any names, email addresses and job functions for those who will be attending



THANK YOU!
FOR ALL YOUR EFFORTS



HMAS

