



**SALES AND MARKETING
UPDATE**



HMAS

January 2026



- Products and Price List
- Video
- Tooling
- Marketing
- Did You Know...

Products and Price List Update

Products and Price List Update

- Release UMC-1250SS/50 for sale in all regions
- Release VR-5 for sale in US/MX regions
- Release ST-55Y, ST-55S, and ST-55SY for sale in all regions
- Release CAMERA MONITOR SGL as an available option on Large & Extra Large VF /VM machines in all regions
- Release BROKEN TOOL DETECT as an available option on Small & Medium VF & VM in all regions. Note that BROKEN TOOL DETECT is not available on VF-3YT/50, VF-5/50, VF-5/50XT, & VF-5/50TR
- Release PALLET POOL-EC-500 and PALLET POOL-READY as available options on EC-500 and EC-500/50 in all regions
- Release 150GAL to replace 66GAL as the standard coolant tank on DC-4/40 in all regions
- Release HPC and HPC1K as available options on SB-35, SB-35L, SB-35Y, and SB-35LY in all regions
- Release GBX35-SB as an available option on SB-35 and SB-35L in all regions
- Release HAB3232 for sale in US/MX. HAB3232 replaces HAB-3232. HAB-3232 is discontinued
- Release HAB3232-CE for sale in HE/CH/CE. HAB3232-CE replaces HAB-3232-CE. HAB-3232-CE is discontinued. Note price increase to \$39,995 (€36,595)
- Release HVS-1-CE for sale in HE/CH/CE regions
- Change price of HKM-1-CE and HML-1-CE to \$26,195 (€23,995) in HE/CH/CE regions

Products and Price List Update

- Release UMC-1250SS/50 for sale in all regions



UMC-1250SS/50

Starting Price: US\$391,995

The UMC-1250SS/50 is a Super-Speed version of our 50-taper UMC-1250/50 that combines the large travels and big platter of the Haas UMC-1250 with a 12,000-rpm, 50-taper inline-spindle, faster rapids, and higher trunnion speeds to reduce cycle times for 3+2 machining and simultaneous 5-axis machining of larger parts. The larger contact area of the 50-taper spindle allows the use of longer tools for deep pockets and better access to complex geometries.

- 5-axis simultaneous machining
- 12,000-rpm 50-taper inline spindle
- High-speed trunnion and faster rapids
- Large-capacity side-mount tool changer
- Includes Wireless Intuitive Probing System

50
TAPER

5
AXIS

12k
RPM

30+1
TOOL CAPACITY

Products and Price List Update

- Release VR-5 for sale in US/MX regions

VR-5

Starting Price: US\$249,995

The VR-5 brings 2-axis spindle head capabilities to our mid-size VMC platform to create a compact 5-axis machine for profiling and contouring mid-size parts. The machine's smaller footprint – 40% smaller than the large-frame VR-8 – makes it well suited for shops where space is at a premium.

Standard features include a 24,000-rpm integral-motor spindle, a 50+1 side-mount tool changer, and a 54" x 24" (1372 x 610 mm) T-slot table that easily supports longer workpieces and fixtures. The 2-axis gimbaled head provides ± 245 degrees of C-axis rotation and ± 120 degrees of B-axis tilt to access nearly any angle for complex shapes, undercuts, and 5-side machining, and brakes on the B and C axes provide plenty of rigidity for 3+2 machining.

- 24,000-rpm integral motor spindle
- ± 245 degrees of C-axis rotation and ± 120 degrees of B-axis tilt
- 50+1 side-mount tool changer
- 5-axis simultaneous machining
- Brakes on the B and C axes for rigid 3+2 machining
- Includes Tool Center Point Control



BT30
TAPER

5
AXIS

24k
RPM

50+1
TOOL CAPACITY

Products and Price List Update

- Release **ST-55Y**, ST-55S, and ST-55SY for sale in all regions



ST-55Y Large-Bore Y-Axis Lathe

Starting Price: US\$399,995

The Haas ST-55Y is a Y-axis version of our large-bore ST-55 turning center, providing the same heavy cutting ability, extreme rigidity, and high thermal stability, while adding Y-axis and C-axis motion for secondary operations. The twin-chuck capability, high-torque spindle, and large through-bore make the ST-55Y ideal for machining heavy pipes and fittings, large couplers, and long rollers. The addition of Y-axis motion, C-axis interpolation, and live tooling allows milling, drilling, and tapping for increased machine capabilities.

- 12-station base mount turret (BMT75)
- Front and rear A1-20 spindle nose with 12.5" (318 mm) bore
- Y-axis milling, drilling, and tapping
- ± 3.0 " (76 mm) Y-axis travel
- Fully interpolated C-axis

12.5"
BAR CAPACITY

1k
RPM

55 hp
POWER

Note – Does not include Reboot of Basic 2-Axis ST-55

Products and Price List Update

- Release ST-55Y, **ST-55S**, and ST-55SY for sale in all regions



ST-55S Large-Bore Lathe

Starting Price: US\$314,995

The Haas ST-55S is a short-bed version of our large-bore ST-55 turning center, providing the same heavy cutting ability, extreme rigidity, and high thermal stability, while taking up less floor space. The twin-chuck capability, high-torque spindle, and large through-bore make the ST-55S ideal for machining heavy pipes and fittings, large couplers, and long rollers.

- Front and rear spindle noses (dual-chuck capability)
- Extra-large spindle nose and spindle bore
- 2-speed gearbox
- Fully programmable servo tailstock

12.5"
BAR CAPACITY

1k
RPM

55 hp
POWER

COMPARE MACHINES

EXPLORE ALL INVENTORY

Note – Does not include Reboot of Basic 2-Axis ST-55

Products and Price List Update

- Release ST-55Y, ST-55S, and **ST-55SY** for sale in all regions



ST-55SY Large-Bore Y-Axis Lathe

Starting Price: US\$377,995

The Haas ST-55SY is a short-bed, Y-axis version of our large-bore ST-55 turning center, providing the same heavy cutting ability, extreme rigidity, and high thermal stability, while taking up less floor space. The twin-chuck capability, high-torque spindle, and large through-bore make the ST-55SY ideal for machining heavy pipes and fittings, large couplers, and long rollers. The addition of Y-axis motion, C-axis interpolation, and live tooling allows milling, drilling, and tapping for increased machine capabilities.

- 12-station base mount turret (BMT75)
- Front and rear A1-20 spindle nose with 12.5" (318 mm) bore
- Y-axis milling, drilling, and tapping
- ± 3.0 " (76 mm) Y-axis travel
- Fully interpolated C-axis

12.5"
BAR CAPACITY

1k
RPM

55 hp
POWER

Note – Does not include Reboot of Basic 2-Axis ST-55

Products and Price List Update

- Release CAMERA MONITOR SGL as an available option on Large & Extra Large VF/VM machines in all regions



Camera Monitor System, Single

*Starting Price: **US\$1,995***

Single camera and LCD monitor to view your machining

Products and Price List Update

- Release BROKEN TOOL DETECT as an available option on Small & Medium VF & VM in all regions. Note that BROKEN TOOL DETECT is not available on VF-3YT/50, VF-5/50, VF-5/50XT, & VF-5/50TR

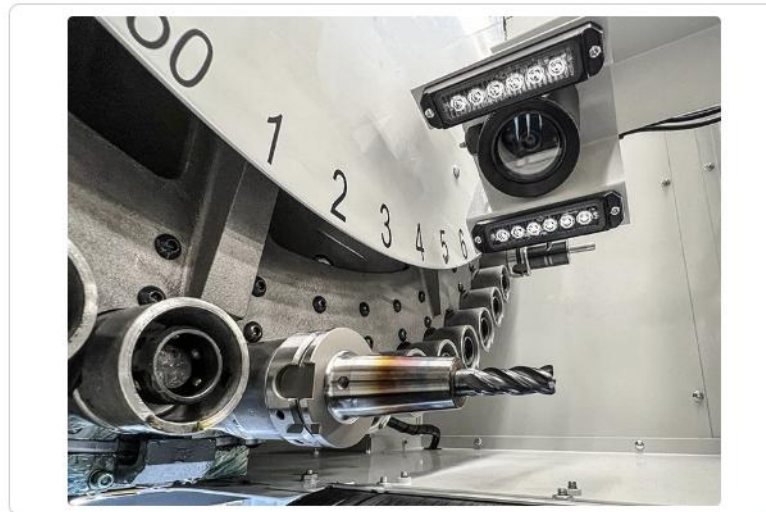

Broken Tool Detection

Starting Price: **US\$1,995**



- Available on all UMCs* **Plus, most SM & Med VMCs**
- Safely stops the machine if a broken tool is detected
- Saves money by preventing damage to tooling, workholding, and possibly the machine

*Except the UMC-350HD-EDU.

The Haas Broken Tool Detection system uses a built-in camera to visually compare tools before and after a tool change, to determine if the tool was damaged during machining. If a broken tool is detected, the machine generates an alarm, and prevents the tool from being swapped into the spindle.

NOTE: Not compatible with right-angle heads.

OPTION INFO



DOCUMENTS



AVAILABLE ON THESE MACHINES

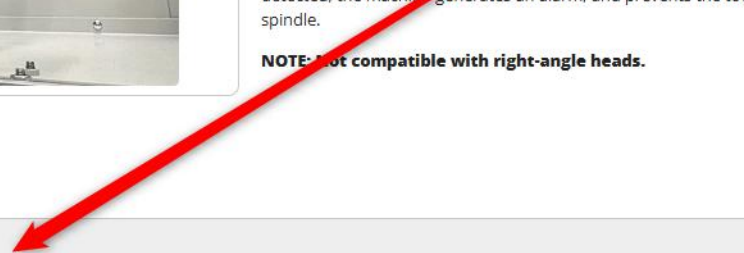

Products and Price List Update

- Release PALLET POOL-EC-500 and PALLET POOL-READY as available options on EC-500 and EC-500/50 in all regions



6+1 Pallet Pool for EC-500 HMCs

*Starting Price: **US\$119,995***

High-volume production, unattended operation

6+1
STATIONS

500 mm
PALLET SIZE

Available for order, with estimated delivery Q2 2026.

Products and Price List Update

- Release 150GAL to replace 66GAL as the standard coolant tank on DC-4/40 in all regions

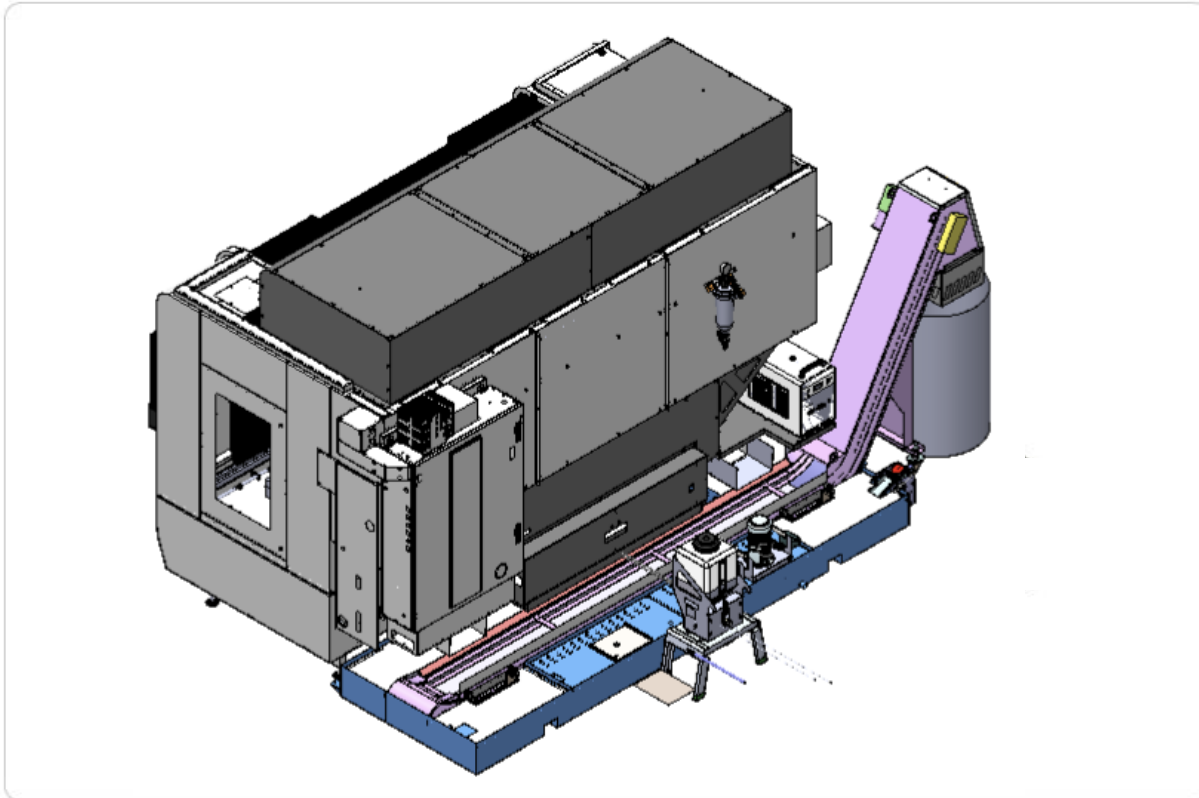

150-Gallon Coolant Tank

Standard on some models



Standard coolant tank for DC-40/40

Products and Price List Update

- Release HPC and HPC1K as available options on SB-35, SB-35L, SB-35Y, and SB-35LY in all regions

SB-35 Box Way Lathe Build-&-Price

Base Price **US\$106,995** Payments as low as **US\$1,857/mo** 60 months ▾

Current Configuration	Coolant & Air Delivery	
Spindles	 HIGH-PRESSURE COOLANT, 300 PSI (21 BAR) WATCH VIDEO > US\$151/mo US\$8,695	 HIGH-PRESSURE COOLANT, 1K WATCH VIDEO > US\$193/mo US\$11,095
Turrets & Live Tooling		
Probing		

Products and Price List Update

- Release GBX35-SB as an available option on SB-35 and SB-35L in all regions



2500-rpm Gearbox Spindle

Starting Price: **US\$13,995**

Gear-driven spindle for the SB-35 Series

2.5k
SPEED

A2-8
NOSE

40 hp
POWER

Gearbox
DRIVE

OPTION INFO

TORQUE CHART

3 Times the torque of Standard Belt Drive

Products and Price List Update

- Release HAB3232 for sale in US/MX. HAB3232 replaces HAB-3232. HAB-3232 is discontinued



HAB3232 Automatic Bandsaw

Starting Price: US\$39,995



- Max cutting height – 12.6" (320 mm)
- Max cutting width – 12.6" (320 mm)
- AI mode
- Wheel adjustable feedrate
- Hydraulic blade tension
- Automatic chip auger
- Bar stacking capability
- Manual and automatic modes
- Memory for multiple jobs

Elevate shop productivity and precision with the Haas HAB3232 Automatic Bandsaw, designed to meet the rigorous demands of automated metal cutting. Engineered for precision, our bandsaw delivers smooth, clean cuts on a variety of metals, from steel to aluminum. The HAB3232 can cut different lengths in the same cycle, and has bar-stacking capability for extra efficiency.

Featuring an intuitive control panel, the HAB3232 offers user-friendly operation. Use AI Mode to let the saw determine its own feedrate, or use the adjustment wheel to make fine adjustments and determine what feedrate works best.

Products and Price List Update

- Release HAB3232-CE for sale in HE/CH/CE. HAB3232-CE replaces HAB-3232-CE. HAB-3232-CE is discontinued. Note price increase to \$39,995 (€36,595).



HAB3232-CE Automatic Bandsaw

Starting Price: 36.595 €



- Max cutting height – 12.6" (320 mm)
- Max cutting width – 12.6" (320 mm)
- AI mode
- Wheel adjustable feedrate
- Hydraulic blade tension
- Automatic chip auger
- Bar stacking capability
- Manual and automatic modes
- Memory for multiple jobs
- Full CE safety controls and guarding

Elevate shop productivity and precision with the Haas HAB3232-CE Automatic Bandsaw, designed to meet the rigorous demands of automated metal cutting. Engineered for precision, our bandsaw delivers smooth, clean cuts on a variety of metals, from steel to aluminum. The HAB3232-CE can cut different lengths in the same cycle, and has bar-stacking capability for extra efficiency.

Featuring an intuitive control panel, the HAB3232-CE offers user-friendly operation. Use AI Mode to let the saw determine its own feedrate, or use the adjustment wheel to make fine adjustments and determine what feedrate works best.

Includes full CE safety controls and guarding.

- Release HVS-1-CE for sale in HE/CH/CE regions.



HVS-1-CE Vertical Bandsaw

Starting Price: 13.695 €

The Haas HVS-1-CE is a variable-speed vertical bandsaw with a 13" x 20" (330 x 510 mm) (H x W) cutting capacity and an adjustable table. It comes equipped with an adjustable coolant mist system to manage blade and material temperatures, and a removable chip tray to catch discarded chips.

Includes full CE safety controls and guarding.

- Blade guide lock
- Table tilt control
- Mist spray system
- Foot pedal switch
- LED worklight
- Full CE safety controls and guarding

Current Lead Time [↗](#)

2 Weeks - Contact your local HFO for delivery times.

Products and Price List Update

- Change price of HKM-1-CE and HML-1-CE to \$26,195 (€23,995) in HE/CH/CE regions.



HKM-1-CE Knee Mill

Starting Price: 23.995 €

The Haas HKM-1 is a traditional-style knee mill with a 9" x 49" (229 x 1245 mm) table and a 4500-rpm R8 spindle. Includes spindle and table guarding to comply with CE safety regulations.

- 32.7" x 12" x 16" (831 x 305 x 406 mm) travels
- Variable-speed 4500-rpm R8 spindle
- Pneumatic power drawbar
- X-axis power feed w/clutch handles
- XY DRO
- Digital quill scale
- Coolant system w/chip tray
- Automatic lubrication system
- CE-compliant safety guarding

[See Available Stock](#)

9 Available - Configurations Vary
Contact Your HFO for Details



HML-1-CE Manual Lathe

Starting Price: 23.995 €

The Haas HML-1-CE is a CE-compliant traditional-style manual engine lathe with a 14" x 39" (360 x 1000 mm) max capacity and 9" (229 mm) manual chuck.

- D1-6 nose with MT6 internal taper
- 9" (229 mm) manual 3-jaw chuck
- 2000-rpm spindle
- Digital Readout (DRO)
- Manual tailstock with MT4 quill
- 4-way tool post
- Steady rest
- Coolant system
- Includes tool kit and box
- CE-compliant safety guarding

[Get Quote](#)

Video Update

Video Update

Recently Released Videos

- New Smart Height Gauges on HaasTooling.com - Haas Automation, Inc. - <https://www.youtube.com/watch?v=AkAu2lhwmK0>
- Haas UMC-1250/50 Cutting with Long Gage Length Tools - Haas Automation, Inc. - https://www.youtube.com/watch?v=6cHx1K_h3Oc
- TouchDMIS Software Introduction - Haas HMM430 CMM - HaasTooling.com - <https://www.youtube.com/watch?v=SS6ArIXSSBU>
- Essential Holemaking Tips! Drill, Center, Spot, Ream, and C'sink Better - Haas Automation, Inc. - <https://www.youtube.com/watch?v=2myKPCvTZi4>

Video Update

Recently Released Videos

- New Smart Height Gauges on HaasTooling.com - Haas Automation, Inc. - <https://www.youtube.com/watch?v=AkAu2lhwmK0>

Haas Tooling Video

- Informative Video
- Shows off features and use of Haas Smart Height Gauges
- Great alternative prior to stepping up to a CMM
- Check it out
- Share as needed



Video Update

Recently Released Videos

- Haas UMC-1250/50 Cutting with Long Gage Length Tools - Haas Automation, Inc. - https://www.youtube.com/watch?v=6cHx1K_h3Oc

Cutting Demo Video

- Shows off machine cutting
- Long Gage Length Tools
- Check it out
- Share as needed



Video Update

Recently Released Videos

- TouchDMIS Software Introduction - Haas HMM430 CMM - HaasTooling.com - <https://www.youtube.com/watch?v=SS6ArIXSSBU>

Haas Tooling Video

- Informative video
- Overview of TouchDMIS software
- Check it out
- Share with customers



Video Update

Recently Released Videos

- Essential Holemaking Tips! Drill, Center, Spot, Ream, and C'sink Better - Haas Automation, Inc. - <https://www.youtube.com/watch?v=2myKPCvTZi4>

Haas Tooling Video

- Informative video
- Tips & Tricks for Holemaking
- Check it out
- Share as needed



Tooling Update

Tooling Update

New Year Sale - Tool Up & Stock Up
SAVE UP TO 30% OFF High-Performance Tooling

[Shop New Year Sale](#)



WINNER'S CIRCLE Update

Still On Sale - Only \$49 – 50% off the already reduced price

Over 16,000 Subscriptions and Growing

Tooling Update, Global Except Europe & China



Bore Gauge Setting Master Kit, 0-6" Range, 36-Piece Gauge Blocks Set, AS-2, NIST Traceable

Part #: 09-0986

\$399.95



3/8" Dia. 45° Carbide Back Chamfer Mill, 6 Flute, Uncoated 0.066" LOC x 1.191" Neck Length

Part #: 03-3424

\$96.95



Sale

Right-Angle 3/8" Tap Sleeve/Collet

Part #: 04-1842

\$289.97

~~\$304.95~~

+46 Items



10-Piece, ISO30 Inch Toolholder Kit

Part #: 08-2066

\$934.97

~~\$1,099.95~~



Right-Angle BT40 Half-Series Drill/Mill Angle Head, Haas Toolholding by MST/Kitagawa

Part #: 04-1864

\$2,561.97

~~\$2,695.95~~



Right-Angle BT40 Half-Series Tap Angle Head, Haas Toolholding by MST/Kitagawa

Part #: 04-1865

\$2,656.97

~~\$2,795.95~~



Right-Angle BT40 Mini Half-Series Drill/Mill/Tap ER-11 Angle Head, Haas Toolholding by MST/Kitagawa

Part #: 04-1866

\$3,134.97

~~\$3,299.95~~



ISO30 10mm End Mill Holder x 50mm Gage Length, TSC

Part #: 04-1780

\$69.95



Hard Steel 4" x 1" CARVESMART SMARTstopped Non-Machinable Vise Jaws by KURT

- Bore Gauge Setter, Master Kit 0-6" Range
- 14 Back Chamfer End Mills
- Right Angle Tap Collets
- 10 & 20-Piece, ISO30 Inch Toolholder Kits
- Right-Angle BT40 Half-Series Drill/Mill Angle Head
- Right-Angle BT40 Half-Series Tap Angle Head, Haas Toolholding by MST/Kitagawa
- Right-Angle BT40 Mini Half-Series Drill/Mill/Tap ER-11 Angle Head, Haas Toolholding by MST/Kitagawa
- ISO30 End Mill Holders, TSC
- Jaws for Mill Work Holding



WINNER'S CIRCLE Update

Still On Sale - Only €49 – 50% off the already reduced price

Over 16,000 Subscriptions and Growing

HAE - Tooling Update



+1 Items

- Bore Gauge Setter

Marketing Update



20 INVENTORY 26
REDUCTION
LIMITED-TIME EVENT

LEARN MORE

TOOL UP & STOCK UP!
NEW YEAR SALE

UP TO **30% OFF**
4,500+ TOOLS ON SALE



FREE NEXT-DAY DELIVERY FOR A YEAR JOIN WINNER'S CIRCLE **\$49** ~~(\$95)~~

SHOP HAAS TOOLING

Marketing Update



20% INVENTORY REDUCTION
LIMITED-TIME EVENT

This advertisement features a yellow and black background with an image of several Haas industrial machines. The text is prominently displayed in white and yellow.



VOP
VALUE OPTION PACKAGES
A NEW WAY TO SAVE

The advertisement has a grey background with a circular inset showing a person's hands using a handheld device. The text is in large, bold, black and red fonts.



TOOL UP & STOCK UP!
NEW YEAR SALE
UP TO 30% OFF
4,500+ TOOLS ON SALE

FAST & FREE DELIVERY
LOW PRICES
HIGH QUALITY

FREE NEXT-DAY DELIVERY FOR A YEAR JOIN WINNER'S CIRCLE **\$49**

This advertisement features a red and yellow background with a circular seal containing an image of a tool. The text is in bold, white and yellow fonts.



SAVE 30% **VC-400SS** **\$72,000**
SAVE UP TO **\$72,000**
ON SPECIALLY CONFIGURED MODELS

The advertisement has a yellow and black background with an image of the VC-400SS machine. The text is in large, bold, white and yellow fonts.



SR-3015 & SR-4020 SHEET ROUTERS
50% OFF
LIMITED-TIME SAVINGS

This advertisement features a yellow and black background with an image of the sheet routers. The text is in large, bold, white and yellow fonts.



**20 INVENTORY 26
REDUCTION
LIMITED-TIME EVENT**

Begin the new year with big savings on in-stock Haas machines.
For a limited time only, take advantage of reduced pricing as we clear out inventory for 2026 models.

Hot Deals – 15% to 50% Off

Demo Machines – 10% to 40% Off (12 Units)

Canceled Orders – 25% to 30% Off

70+ Units in stock

Marketing Tools

View Edit Track Devel

*** All images are clickable ***



HAAS TOOLING HOME PAGE

[Haas Tooling Promo page](#)

[How to redeem Online Tooling Promos](#)

2025 AVAILABLE DIGITAL MARKETING CAMPAIGNS and MODEL GUIDES, PDFs, CATALOGS

*Check Marketing Campaign page for info about HFO Demo Day.

Tooling Kits Explained (08/PCK/EK)

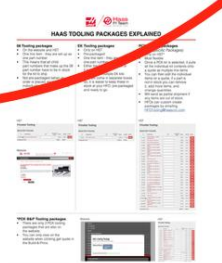
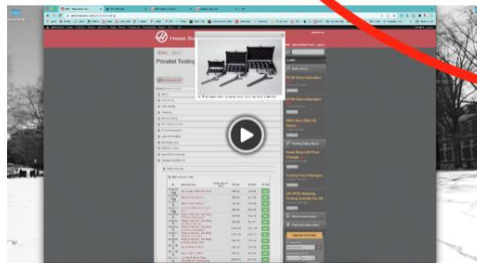

Reduced pricing as we clear out inventory for 2026 models.

Date updated: January 5, 2026

Landing Page ↓



Email ↓



SR-3015 & SR-4020 SHEET ROUTERS

Marketing Campaign Update

2026 AVAILABLE DIGITAL MARKETING CAMPAIGNS + MODEL GUIDES/PDFS/CATALOGS

These campaigns will be running throughout 2026. Email HFOEmailSupport@haascnc.com if you want to have Haas email your customer base regarding any of the below campaigns.

CURRENT LIVE MARKETING CAMPAIGNS

NEW Marketing Campaigns added

- **160-Pocket Side-Mount Tool Changer *NEW**
- **HML-1 Manual Lathe *NEW**
- **120-Pocket Side-Mount Tool Changer *NEW**
- **Mill-Spindle C-Axis *NEW**
- **Knee Mill *NEW**
- **Box Way Lathe *NEW**
- **HFL-3015 Fiber Laser *NEW**
- **DMs/DTs *NEW**
- **Hot Deals on In-Stock Machines *NEW**
- **Financing Rates *NEW**
- **SR-3015 Sheet Router *NEW**
- **HFO Demo Day *NEW**
- **DC-Series *NEW**
- **GM-1 Gantry Mills *NEW**

NEW Sales

- **Flash Sale *NEW**
- **2026 Inventory Reduction Event *NEW**
- **Value Option Packages (VOP) *NEW**

Ongoing Marketing Campaigns Available

- EU Models
- Mini Mill Redesign
- Rotaries
- Customer Testimonials
- Showroom Machines/Local Inventory
- Energy Savings
- New to CNC
- New to Haas
- Advanced Haas User
- Industry – Aerospace
- Industry – Firearms
- Industry – Medical/Dental
- Haas Makes It Easy
- Why Haas
- First-Time Buyers
- Small Footprint
- Affordable Machines
- Most Popular Machine
- Robot Competition
- Most Popular Machine
- Fully Integrated Pallet Pools
- Why Buy a Robot
- Trade In, Trade Up
- Machine Highlight
- Small VF
- EC-400
- VC-400
- UMC-500
- 50-Taper
- ST-28Y
- VF-2YT Series Pallet Pool

TOOLING MARKETING CAMPAIGNS

- **Haas Cobot *NEW**
- Benefits of Haas Tooling
- Haas Workholding by Kurt
- Ready2Run
- Ready2Machine

PDFS/CATALOGS/MODEL GUIDES

Available in Multiple Languages

- **Haas Journal *NEW**
- **Model Guides *NEW**
- **Shop Notes *NEW**
- EU Series PDFs
- Haas Tooling Winner's Circle Introduction Flyer
- Haas Tooling Winner's Circle Letter
- Haas Tooling Winner's Circle Poster
- Haas Tooling 4 Pagers
- Haas Tooling Catalog
- Haas Guide to Automation: Robots
- V-Model PDFs
- Catalog on Haas Automated Systems

HFO EVENTS

Fill out the survey below to start the process of getting marketing materials created for your event. You must submit the survey a minimum of 2 months before your event. *Date updated: Jan 2025*

[EVENT SURVEY](#)

**Click here for the Demo Day survey and marketing materials.*

Rate Factors for CNCA Promos for USA, Canada, & HAE - July 2025 pb JM .xlsx

HFO Blind Discount is 1% of the financed amount

**Changed from Sep 2025 - Most Programs Increased by .50%.
0.00% Programs Increase to 0.99%.
180 Day Skip Program was Removed.**

Effective Jan 1, 2026

Term	Skip Days	Months						
		12	24	36	48	60	72	84
10%		0.99%	2.99%	3.99%	4.99%	5.49%		
20%		0.99%	1.99%	2.99%	3.49%	4.99%	5.99%	6.49%
25%		0.99%	0.99%	1.99%	2.99%	3.99%	5.49%	5.99%
30%		0.99%	0.99%	0.99%	1.99%	3.49%	4.99%	5.49%
50%		0.99%	0.99%	0.99%	0.99%	3.49%	4.99%	5.49%
20%	90	1.99%	2.49%	3.49%	4.49%	5.99%	6.49%	6.74%

Term	Skip Days	RATE FACTORS						
		12	24	36	48	60	72	84
10%		0.08378	0.04298	0.02952	0.02303	0.01910		
20%		0.08378	0.04254	0.02908	0.02235	0.01887	0.01657	0.01485
25%		0.08378	0.04210	0.02864	0.02213	0.01842	0.01634	0.01461
30%		0.08378	0.04210	0.02821	0.02169	0.01819	0.01611	0.01437
50%		0.08378	0.04210	0.02821	0.02126	0.01819	0.01611	0.01437
20%	90	0.08452	0.04294	0.02947	0.02297	0.01953	0.01699	0.01514



FINANCING RATES*NEW

CNCA Financing Rates have been updated.

Available for: US, Canada, HAE (Denmark, Germany, France, Spain, Portugal, Belgium, Luxembourg, Estonia, Latvia, Lithuania, Czech Republic, Slovakia, and Greece)

Date updated: January 5, 2026

Rates Chart

Rate Factors for CNCA Promos for USA, Canada, & HAE - July 2025 pb JM .xlsx

HFO Blind Discount is 1% of the financed amount

**Changed from Sep 2025 - Most Programs Increased by .50%.
0.00% Programs Increase to 0.99%.
180 Day Skip Program was Removed.**

Term	Skip Days	Months						
		12	24	36	48	60	72	84
10%		0.99%	2.99%	3.99%	4.99%	5.49%		
20%		0.99%	1.99%	2.99%	3.49%	4.99%	5.99%	6.49%
25%		0.99%	0.99%	1.99%	2.99%	3.99%	5.49%	5.99%
30%		0.99%	0.99%	0.99%	1.99%	3.49%	4.99%	5.49%
50%		0.99%	0.99%	0.99%	0.99%	3.49%	4.99%	5.49%
20%	90	1.99%	2.49%	3.49%	4.49%	5.99%	6.49%	6.74%

Term	Skip Days	RATE FACTORS						
		12	24	36	48	60	72	84
10%		0.08378	0.04298	0.02952	0.02303	0.01910		
20%		0.08378	0.04254	0.02908	0.02235	0.01887	0.01657	0.01485
25%		0.08378	0.04210	0.02864	0.02213	0.01842	0.01634	0.01461
30%		0.08378	0.04210	0.02821	0.02169	0.01819	0.01611	0.01437
50%		0.08378	0.04210	0.02821	0.02126	0.01819	0.01611	0.01437
20%	90	0.08452	0.04294	0.02947	0.02297	0.01953	0.01699	0.01514

RATES CHART

2026 CNCA Payment Calculator

\$ Total Debt	Down Payment	12 Months	24 Months	36 Months	48 Months	60 Months	72 Months	84 Months
\$ 20,000.00	\$ 2,000.00	\$ 1,740.40	\$ 1,402.20	\$ 1,206.40	\$ 1,009.70	\$ 872.00	\$ 759.00	\$ 668.00
\$ 20,000.00	\$ 4,000.00	\$ 1,585.50	\$ 1,287.50	\$ 1,106.50	\$ 928.50	\$ 798.50	\$ 695.50	\$ 610.50
\$ 20,000.00	\$ 6,000.00	\$ 1,484.40	\$ 1,247.00	\$ 1,074.70	\$ 908.80	\$ 787.80	\$ 688.80	\$ 605.80
\$ 20,000.00	\$ 8,000.00	\$ 1,428.50	\$ 1,207.50	\$ 1,042.50	\$ 882.50	\$ 765.50	\$ 668.50	\$ 587.50
\$ 20,000.00	\$ 10,000.00	\$ 1,383.50	\$ 1,172.50	\$ 1,007.50	\$ 847.50	\$ 734.50	\$ 641.50	\$ 562.50

CNCA PAYMENT CALCULATOR - EXCEL FILE

Rates PDF for US Customers

(Updated January 5, 2026)

Rates PDF for HAE Customers

(Updated January 5, 2026)



US CUSTOMER FINANCING PDF



HAE CUSTOMER FINANCING PDF

Marketing Update

 DOZENS OF WAYS TO **SAVE**

LOWEST DOWN PAYMENT

10% DOWN
5.49% INTEREST FOR 60-MONTHS.

PAYMENTS AS LOW AS
\$1,719 PER MONTH

LOWEST INTEREST

0.99% FOR 48 MONTHS
REQUIRES LARGER DOWN PAYMENT

PAYMENTS AS LOW AS
\$1,063 PER MONTH

LONGEST TERM

84-MONTH TERM
WITH RATES AS LOW AS 5.49%*

PAYMENTS AS LOW AS
\$718 PER MONTH

NO PRE-PAYMENT PENALTIES EVER!

UP TO
3-MONTH SKIP
AVAILABLE

SAVE \$6,449 IN INTEREST!
(BASED ON 0.99% FOR 36 MONTHS, COMPARED TO U.S. PRIME RATE AT 6.75% INTEREST)

SAMPLE PAYMENTS ARE BASED ON A \$100,000 CNC MACHINE PURCHASE.

INSANE FINANCING FOR YOUR NEXT HAAS CNC

DOWN PAYMENT	CHOOSE YOUR TERM						
	12-MONTHS	24-MONTHS	36-MONTHS	48-MONTHS	60-MONTHS	72-MONTHS	84-MONTHS
10% DOWN	0.99%	2.99%	3.99%	4.99%	5.49%		
20% DOWN	0.99%	1.99%	2.99%	3.49%	4.99%	5.99%	6.49%
25% DOWN	0.99%	0.99%	1.99%	2.99%	3.99%	5.49%	5.99%
30% DOWN	0.99%	0.99%	0.99%	1.99%	3.49%	4.99%	5.49%
50% DOWN	0.99%	0.99%	0.99%	0.99%	3.49%	4.99%	5.49%
20% DOWN + 3-MO SKIP	1.99%	2.49%	3.49%	4.49%	5.99%	6.49%	6.74%

APPLY FOR FINANCING TODAY

* Financing Terms, Conditions, and Exceptions: References are to an implied interest rate under a conditional sales contract. Interest accrues during the skip period. Down payment, rate, and terms of financing are dependent upon credit approval. Eligible businesses should have three or more years of operation under current ownership. U.S. and Canada only. All programs are 10% - 50% down. Must put a minimum of 20% down to get no payments for 3 months. **Certain equipment (e.g., stand-alone Rotaries, Shop Equipment, Bar Feeders, etc.) are subject to different rates, terms, and down-payment requirements, unless financed with a machine.** No prepayment penalty on any program. Monthly payment does not include applicable taxes, rigging, or freight charges. Not responsible for misprints or typographical errors. Offer valid on new machine orders placed from 1 January - 31 January

2026.

HAE Marketing Update



20% INVENTORY REDUCTION
LIMITED-TIME EVENT

LEARN MORE



NEW YEAR SALE Stock Up for the New Year!

UP TO **-40%**
4,000+ TOOLS ON SALE

FAST & FREE DELIVERY
LOW PRICES • HIGH QUALITY

TOOLING
HAAS

FREE EXPRESS DELIVERY FOR A YEAR
JOIN WINNER'S CIRCLE **49€** (95€)

SHOP HAAS TOOLING

Machines Configured Exclusively for Europe

EU SERIES: UP TO 34% OFF
MORE CHOICES, MORE VALUE - JUST FOR EUROPE

LEARN MORE

HAE Marketing Update

Your Source for the Latest Haas Deals

Discover all the current ways to save with Haas Automation. From limited-time flash sales and in-stock machine discounts to exclusive Haas Tooling promotions and Value Option Package savings, this is your one-stop destination for unbeatable value.

Check back often—new ways to save are added regularly.

**20 INVENTORY 26
REDUCTION**
LIMITED-TIME EVENT

A promotional banner for a 26% inventory reduction event. It features a yellow and black background with images of Haas industrial machines.

EU-SERIES
Haas Lathes & Vertical Mills.
More Choices. More Value.

A promotional banner for the EU-Series of Haas lathes and vertical mills. It features a dark background with red accents and images of the machines.

NEW YEAR SALE Stock Up for the New Year!
UP TO **-40%**
4,000+ TOOLS ON SALE
FREE EXPRESS DELIVERY FOR A YEAR
JOIN WINNER'S CIRCLE **49€**

FAST & FREE DELIVERY
LOW PRICES
HIGH QUALITY
TOOLING
HAAS

A promotional banner for a New Year Sale. It features a red and yellow background with a circular seal that says 'FAST & FREE DELIVERY', 'LOW PRICES', and 'HIGH QUALITY'. The seal also contains the word 'TOOLING' and the Haas logo.

**SR-SERIES
HAAS SHEET ROUTERS**

BUY NOW & GET 25% OFF
FOR A LIMITED TIME ONLY

A promotional banner for the SR-Series of Haas sheet routers. It features a dark background with images of the routers and a stack of promotional cards.



**20 INVENTORY 26
REDUCTION
LIMITED-TIME EVENT**

Begin the new year with big savings on in-stock Haas machines.
For a limited time only, take advantage of reduced pricing as we clear out inventory for 2026 models.

HOT DEALS DEMO & PRE-OWNED CANCELED ORDERS

Hot Deals 20% to 38% Off!
Demo Machines @ 10% to 45% Off!
Canceled Orders @ 20% to 30% Off!

300+ Units in stock

HAE Marketing Update

CHOOSE YOUR FINANCING

**NO MODEL
RESTRICTIONS**

**UP TO 3-MONTH SKIP
AVAILABLE**

**NO PRE-PAYMENT
PENALTIES EVER!**

LOWEST DOWN PAYMENT
**10%
DOWN**

5,49% Interest for as Long as 60-Months.

Payments as Low as
€1.719 PER MONTH

LOWEST INTEREST
**0,99% FOR
48 MONTHS**

Requires Larger Down Payment.

Payments as Low as
€1.063 PER MONTH

LONGEST TERM
**84-MONTH
TERM**

With Rates as Low as 5,49%*

Payments as Low as
€718 PER MONTH

Sample payments are based on a €100.000 CNC machine purchase.

SAVE €6.449 IN INTEREST!

(Based on 0,99% for 36 months, compared to lenders with similar terms at 6,75% interest.)

INSANE FINANCING FOR YOUR NEXT HAAS CNC

DOWN PAYMENT	CHOOSE YOUR TERM						
	12-MONTHS	24-MONTHS	36-MONTHS	48-MONTHS	60-MONTHS	72-MONTHS	84-MONTHS
10% DOWN	0,99%	2,99%	3,99%	4,99%	5,49%		
20% DOWN	0,99%	1,99%	2,99%	3,49%	4,99%	5,99%	6,49%
25% DOWN	0,99%	0,99%	1,99%	2,99%	3,99%	5,49%	5,99%
30% DOWN	0,99%	0,99%	0,99%	1,99%	3,49%	4,99%	5,49%
50% DOWN	0,99%	0,99%	0,99%	0,99%	3,49%	4,99%	5,49%
20% DOWN + 3-MO SKIP	1,99%	2,49%	3,49%	4,49%	5,99%	6,49%	6,74%

*Financing terms, conditions, and exceptions: **valid in Denmark, Germany, France, Spain, Portugal, Belgium, Luxembourg, Estonia, Latvia, Lithuania, Czech Republic, Slovenia, Slovakia, and Greece only.** References are to an implied interest rate under a conditional sales contract. Interest accrues during the skip period. Down payment, rate, and terms of financing are dependent upon credit approval. Eligible businesses should have three or more years of operation under current ownership. All programs are 10% - 50% down. Must put a minimum of 20% down to get no payments for 3 months. **Certain equipment (e.g., stand-alone Rotaries, Shop Equipment, Bar Feeders, etc.) are subject to different rates, terms, and down-payment requirements, unless financed with a machine.** No prepayment penalty on any program. Monthly payment does not include applicable taxes, rigging, or freight charges.
 Offer valid on new machine orders placed from **1 January - 31 January 2026.**

Did You Know...

New DOC Page (Dealer Only Content) A new DOC banner on the HBC site & HST

Welcome to Haas Business Center

Notice



Dealer-Only Content (DOC) Access Link



MOTION SENSOR/GELOCATION TROUBLESHOOTING







Latest News [Full List](#)

- 12/10/2025 - Haas Factory Shut Down Schedule [Read More...](#)
- 07/30/2025 - Haas E-Mail Support Contacts - US [Read More...](#)

haascnc.com

Welcome, MSTENBOCKI [Open Machine Report](#) [Log Out](#)

View Edit Track Devel

- ATP** ATP Reports
-  Pricelist | Specs | Availability | Tooling Orders
VMC - HMC - Lathes - Rotary - Shipping Dims - Add Tooling to MO
-  Open Orders and Quotes
-  ES Docs
-  Dealer-Only Content (DOC) Access Link
-  Advanced Sales Information
Sales and Marketing Updates | 2024 Training Presentations | Advanced Product Information

English

Popups History

Sales News

New Site Live - Sales & Marketing NEW

6 days 14 hours ago

January 2026 Price Lists Posted

1 week 5 days ago

Year-End Stock Machines

My Haas Find Your Distributor Select Language mBe@haas-technical.com

MACHINES OPTIONS WHY HAAS SERVICE VIDEOS HAAS TOOLING HAAS SERVICE PARTS SALES & MARKETING

SALES & MARKETING HOME PAGE

Search Haas Sales & Marketing ...

Sales & Marketing

- Haas & HFO Contact Info
- CNC Sales News
- Tooling Sales News
- Sales & Marketing Updates
- Price List Updates
- Haas Tooling
- HST - How To
- Marketing Tools
- Education
- Dealer Policies
- Export Compliance
- Marketing Campaigns
- Financing
- VDP
- Haas Value Selling
- Verticals
- Horizontals
- Lathes
- Rotary
- Shop Equip - Machine Price List
- Options
- Automation
- Tooling Shop Equip - Price List
- Competitor Quotes
- Sales & Marketing Search

CNC Sales News

Fri Jan 16 2026

Laser Cutting Machine Detail

Marketing materials, customer e-mails, and training content for the Haas Laser Cutting...

Tue Jan 06 2026

January 2026 Price Lists Posted

Note that any MO Quotes currently in process will need to be redone if this month's changes...

Fri Dec 12 2025

Year-End Stock Machines

The attached file shows year-end stock machines available for the US, Canada, and...

Wed Dec 10 2025

December Sales & Marketing Update

The November 2025 Sales & Marketing Update has been posted. Click the link below for the...

Mon Dec 01 2025

December 2025 Price Lists Posted

Note that any MO Quotes currently in process will need to be redone if this month's changes...

Tue Nov 11 2025

November Sales & Marketing Update

The November 2025 Sales & Marketing Update has been posted. Click the link below for the...

View All CNC Sales News Updates



PRICE LIST UPDATES

Learn More >



S & M UPDATES

Learn More >



TOOLING OPERATIONS

Learn More >



CONTACT LIST

Learn More >

Tooling Sales News

Thu Jan 15 2026

Anti-Fatigue Floor Mat - Temporarily Out of Stock

undefined

Fri Dec 05 2025

20% Off + \$500 HPD Credit on Air Compressors

undefined

Fri Dec 05 2025

Holiday Sale 12-8

Sale Pricing is valid from December 8 - January 3. Please view the attached Excel files that show...

Wed Nov 26 2025

Cyber Week Sale Pricing 12-1

Sale Pricing is valid from November 29 - December 5. Please view the attached Excel...

Fri Nov 21 2025

Black Friday Sale Update: 11-22

The attached sheet features an updated list of tools on sale, valid from November 22 - ...

Fri Oct 31 2025

Black Friday 11-3

Sale Pricing is valid from November 3 - November 31. Please view the attached Excel...

View All Tooling Sales News Updates

Did You Know...

SB-28 & 28Y 40 Gal. (151L) Coolant Tank Clearance

*Does not apply to SB-35 Series

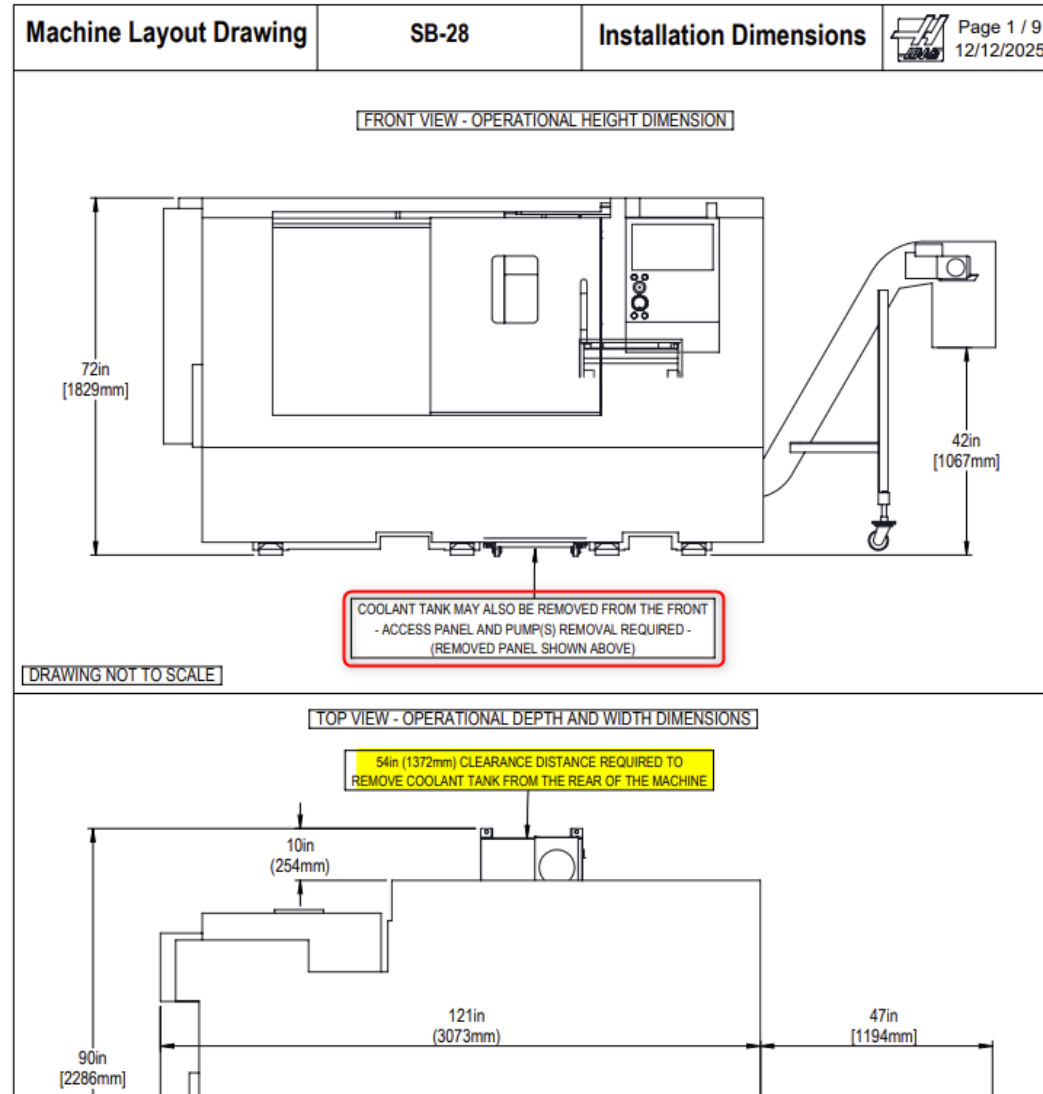

Did You Know...

Super Speed UMCs

True interpolated 5-Axis motion, should always favor the Super Speed models

Not just about spindle speed and Rapids...

* Does not apply to UMC-400s

UMC-500		UMC-500SS
	24.0" x 16.0" x 16.0" (xyz) 610 x 406 x 406 mm Starting Price: US\$148,995	24.0" x 16.0" x 16.0" (xyz) 610 x 406 x 406 mm Starting Price: US\$176,995
DOWNLOAD PDF	EXPORT CSV	BUILD & PRICE
UNIT OF MEASUREMENT: S.A.E <input checked="" type="radio"/> METRIC <input type="radio"/>		BUILD & PRICE
B AXIS - TILT	S.A.E	S.A.E
Travel	120 ° to 35- °	120 ° to 35- °
Max Speed	50 °/sec	179 °/sec 358% More Speed
Torque (Continuous)	1854 ft-lbf	1854 ft-lbf
Brake Torque	900 ft-lbf	900 ft-lbf
C AXIS - ROTATION	S.A.E	S.A.E
Travel	360 °	360 °
Max Speed	50 °/sec	179 °/sec 358% More Speed
Torque (Continuous)	1854 ft-lbf	1854 ft-lbf
Brake Torque	900 ft-lbf	900 ft-lbf
Max Part Swing	18.0 in	18.0 in
FEEDRATES	S.A.E	S.A.E
Max Cutting	650 ipm	833 ipm 28% More Speed
Rapids on X	900 ipm	1200 ipm
Rapids on Y	900 ipm	1200 ipm
Rapids on Z	900 ipm	1200 ipm

Cancellation Policy

Dealer Policies

GENERAL POLICIES

SPR/ PC CODES/ DISCOUNTING

FREIGHT & SHIPPING POLICIES

Terms of Sale

Certain machine models will be designated as 'Deposit' machines. These machines are sold under specific terms as outlined below

EC-630 | EC-1600ZT-5AX | GM-2-5AX | VRs | HDCs | VSs

Deposit Machine Cancellation Policy – 10% deposit required with the order. If the machine is cancelled before the release of the production order, 50% of the deposit will be refunded. Once a machine is released to production, there is no refund of the deposit for these machines. Non-Deposit Machine Cancellation Policy – For all machines other than those listed above, if a machine is canceled for any reason after the machine has been released to production, a cancellation fee of 2% of the standard net price will be debited to the HFO account. If a machine has completed assembly, the cancellation fee will be 5% of the standard net price.

- Factory Training Dates for 2026
 - March 18/19
 - May 13/14 (New Dates)
 - Dealer Meeting – May 16th
 - August 26/27
 - December 2/3

Please email Scott Gasich directly with any names, email addresses and job functions for those who will be attending



THANK YOU!
FOR ALL YOUR EFFORTS



HMAS

