





**SALES AND MARKETING
UPDATE**



HMAS

July 2025



Topics

- Products and Price List
- Video
- Tooling
- Marketing
- Did You Know...

Products and Price List Update

Products and Price List Update

- DS-20Y & DS-25Y released in all regions
- HDC-3 released in US/CA/MX
- UMC-1250/50 released **in all regions**
- POCKET MILL released **in all regions**
- HML-1 released in US/CA/MX
- HVS-1 released in US/CA/MX
- HMS-3123 released in US/CA/MX
- HRT210VM, and HRT200HS released in all regions
- PALLET POOL-HMC-LG-4 option added to EC-1600ZT in all regions
- SMTC-120 tool changer option added to UMC-750/750SS **in all regions**
- HKM-1-CE released in Europe
- ROBOT PKG-50KG added back to the price list in US/CA/MX
- ROBOT PKG-3 added back to the price list in all regions except US/CA/MX
- CAMERA MONITOR SYS added as standard on VR-8/9/11/14 in all regions
- MIST CONDENSER option added to ST-20L/20LY/25L/25LY/28L/28LY/30L/30LY/35L/35LY all regions
- AUTO DOOR-MILL option added to DC-2/40 in all regions
- SINGLE GRIPPER-CBT30 option added to COBOT PKG-30KG in all regions
- MULTI-STAGE CLT PUMP added as standard on VS-1/3/3-5AX in all regions
- MULTI-STAGE CLT PUMP standard on HDC-3-5AX when CS-GR is selected in all regions
- 10K-HSK-A100 option added to HDC-3-5AX in all regions
- AUTO OPERATOR WINDOW added as standard on HDC-3/3-5AX and GM-1/1XT in all regions
- AUTO WINDOW-DC option removed from DC-3/40 and DC-4/40 in all regions
- ROUTER SOFTWARE PKG option removed from SRs in all regions

Products and Price List Update

- Release DS-20Y in all regions



DS-20Y

Starting Price: US\$155,995

The DS-20Y Y-axis turning center combines dual-spindle turning with Y axis, C axis, and live tooling to create a powerful “done-in-one” machining solution for any shop. Off-center milling, drilling, and tapping operations are possible for increased machining capabilities. It comes standard with a 12-station BMT65 turret and synchronized C axis for versatile 4-axis capability. The opposed spindles support fully synchronized turning, and allow on-the-fly part pass-off to reduce cycle times.

The DS-20Y has a compact footprint, yet provides a generous work envelope. The sub-spindle has a full C-axis for accurate positioning and interpolated live-tooling operations, and a mechanical brake that provides 140 ft-lb (190 Nm) of holding torque for off center milling and drilling.

- Dual-spindle design for done-in-one operations
- Y-axis milling, drilling, and tapping
- Fully interpolated sub-spindle C-axis with mechanical brake
- Ideal for high-volume, high-production environments

8"
CHUCK SIZE

2.5"
BAR CAPACITY

4k
RPM

20 hp
POWER

- Release DS-25Y in all regions



DS-25Y

Starting Price: US\$167,995

The DS-25Y Y-axis turning center combines dual-spindle turning with Y axis, C axis, and live tooling to create a powerful “done-in-one” machining solution for any shop. Off-center milling, drilling, and tapping operations are possible for increased machining capabilities. It comes standard with a 12-station BMT65 turret and synchronized C axis for versatile 4-axis capability. The opposed spindles support fully synchronized turning, and allow on-the-fly part pass-off to reduce cycle times.

The DS-25Y has a compact footprint, yet provides a generous work envelope and a 3.0" (76 mm) bar capacity. The sub-spindle has a full C-axis for accurate positioning and interpolated live-tooling operations, and a mechanical brake that provides 140 ft-lb (190 Nm) of holding torque for off center milling and drilling.

- Dual-spindle design for done-in-one operations
- Y-axis milling, drilling, and tapping
- Fully interpolated sub-spindle C-axis with mechanical brake
- Ideal for high-volume, high-production environments

10"
CHUCK SIZE

3.0"
BAR CAPACITY

3.4k
RPM

30 hp
POWER

- Release HDC-3-5AX in US/CA/MX



HDC-3-5AX

Starting Price: **US\$1,049,995**



- Dual-axis spindle head provides ± 245 degrees of C-axis rotation and ± 120 degrees of B-axis tilt
- HSK-A100 integral-motor spindle
- 50+1 side-mount tool changer
- Control pendant on moveable stand for easy access
- 153" x 49" (3886 x 1245 mm) table, with 3 blank bolt-on tooling plates for custom fixturing
- Fully supported X-axis travel
- 10,000 lb (4536 kg) part capacity

The HDC-3-5AX is a 5-axis double-column mill designed for complex, large-part machining, such as airframe components, layup molds, and composite structures. The machine's rigid construction provides a very stable cutting platform. The fully supported X-axis travels easily handle parts weighing up to 10,000 lb (4536 kg).

NOTE: The table surface consists of three blank tooling plates that are easily machined for custom fixturing. Optional T-slot plates are available.

HSK-A100
TAPER

5
AXIS

6000
RPM

50+1
TOOL CAPACITY

Products and Price List Update

- Release UMC-1250/50 **in all regions**



UMC-1250/50

Starting Price: US\$339,995

The UMC-1250/50 combines the larger travels and bigger platter of the Haas UMC-1250 Universal Machining Center with the power and torque of our 50-taper inline-spindle to create the perfect solution for heavy-duty 3+2 machining and simultaneous 5-axis machining of larger parts.

- 5-axis simultaneous machining
- Powerful 50-taper inline direct-drive spindle
- Large-capacity side-mount tool changer
- Includes Wireless Intuitive Probing System

50
TAPER

5
AXIS

7.5k
RPM

30+1
TOOL CAPACITY

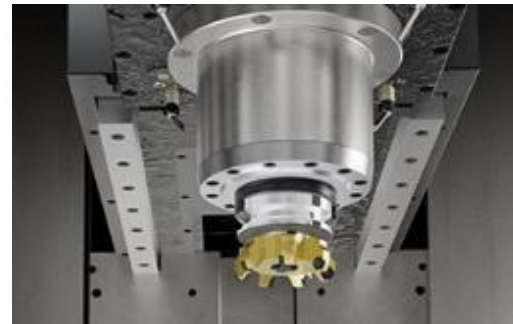

[EXPLORE ALL INVENTORY](#)

Products and Price List Update

- Release POCKET MILL **in all regions**



Pocket Mill

Starting Price: US\$29,995

The Haas Pocket Mill is small enough to fit into nearly any pocket of space in your shop, while providing the features and performance of our full-size machines, at a very affordable price.

It's the perfect choice for start-up shops, schools, hobbyists, garage machinists, or anyone with limited space and a limited budget.

- Full-function, easy-to-use Haas control
- Standard 40-taper spindle
- Available 10-pocket tool changer
- Single- or 3-phase power

40
TAPER

3
AXIS

4k
RPM

1
TOOL CAPACITY

- Release HML-1 in US/CA/MX



HML-1 Manual Lathe

Starting Price: US\$24,995

The Haas HML-1 is a traditional-style manual engine lathe with a 14" x 39" (360 x 1000 mm) max capacity and 9" (229 mm) manual chuck.

- D1-6 nose with MT6 internal taper
- 9" (229 mm) manual 3-jaw chuck
- 1800-rpm spindle
- Digital Readout (DRO)
- Manual tailstock with MT4 quill
- 4-way tool post
- Steady rest
- Coolant system
- Includes tool kit and box

Currently available in the US, Canada, and Mexico only.

Products and Price List Update

- Release HVS-1 in US/CA/MX



HVS-1 Vertical Bandsaw

Starting Price: US\$14,995

The Haas HVS-1 is a variable-speed vertical bandsaw with a 13" x 20" (330 x 510 mm) (H x W) cutting capacity and an adjustable table. It comes equipped with an adjustable coolant mist system to manage blade and material temperatures, and a removable chip tray to catch discarded chips.

- Blade guide lock
- Table tilt control
- Mist spray system
- Foot pedal switch
- LED worklight

COMPARE MACHINES

EXPLORE ALL INVENTORY [↗](#)

Currently available in North America only.

- Release HMS-3123 in US/CA/MX



HMS-3123 Mitre Bandsaw

Starting Price: US\$12,995

The Haas HMS-3123 Miter Bandsaw combines precision cutting and multi-angle flexibility to allow dual miter cuts from 0° to 60°. The machine's intelligent control system, powerful hydraulic clamping, and durable blade guidance system ensure efficient and accurate performance across a wide range of cutting tasks. Whether you're cutting structural steel, pipes, or complex profiles, the HMS-3123 provides stable and reliable multi-angle cutting to boost your production efficiency.

- Cutting range 90° flat – 12.2" x 9" (310 x 230 mm)
- Cutting range 90° round – 9" (230 mm)
- 0° - 60° mitering range
- Hydraulic clamping
- Blade breakage detection
- LED worklight
- CE standard safety protection

COMPARE MACHINES

EXPLORE ALL INVENTORY [↗](#)

Currently available in North America only.

Products and Price List Update

- Release HRT210VM in all regions

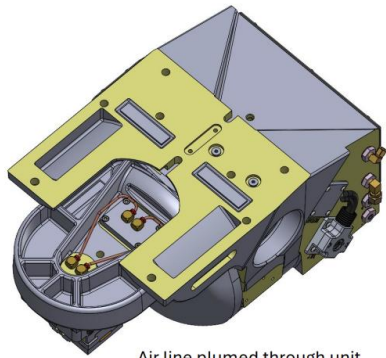
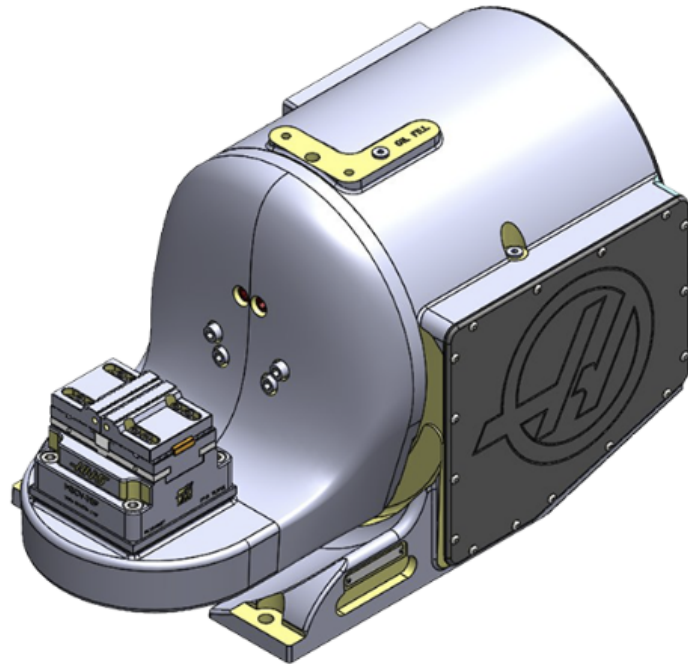

Air line plumbed through unit

HRT210VM

Starting Price: US\$19,995

The HRT210VM is a single-axis tilting rotary table with a built-in vise mount at 90°. The rotary comes pre-assembled and pre-plumbed with a 3" (75 mm) pneumatic vise that can be controlled manually or via the Haas control.

Note: Requires a Haas mill with 4th-axis drive and **NGC software version 100.21.000.1130** or later for full 4th-axis operation.

- Compact design
- Built-in vise mount with 3" (75 mm) vise
- 425 ft-lb (576 Nm) brake torque for heavy 3+2 machining
- Cost-effective alternative to full 5th-axis rotary
- Easy plug-and-play connection to Haas machines
- Industry-leading performance and capabilities

1
SPINDLES

210 mm
PLATTER SIZE

300 ft-lb
MAX TORQUE

80 °/sec
MAX SPEED

COMPARE MACHINES

EXPLORE ALL INVENTORY [↗](#)

Products and Price List Update

- Release HRT210VM in all regions
- Work Holding Options

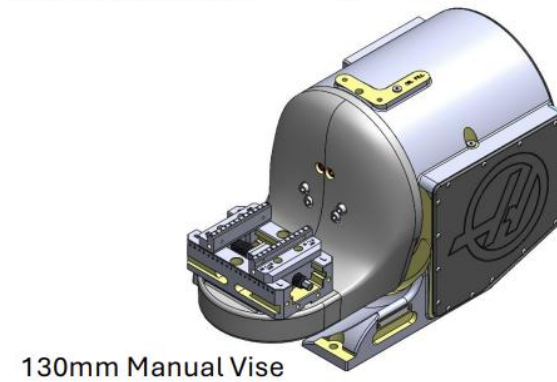
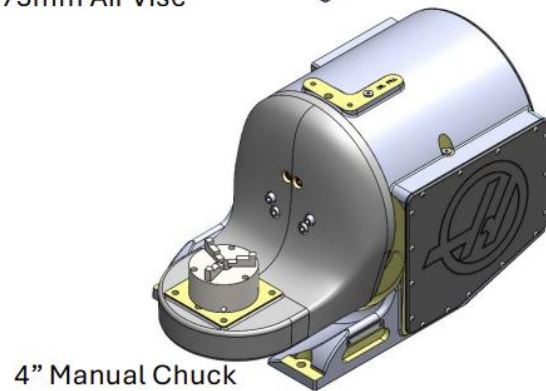
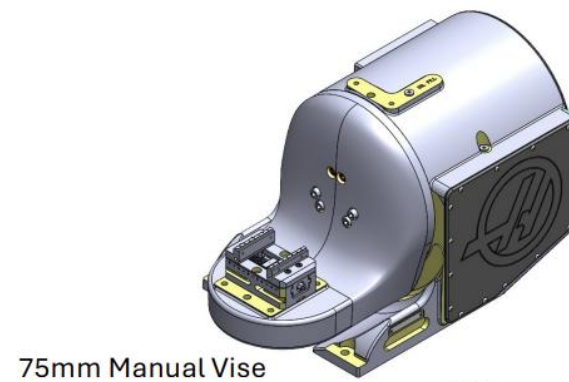
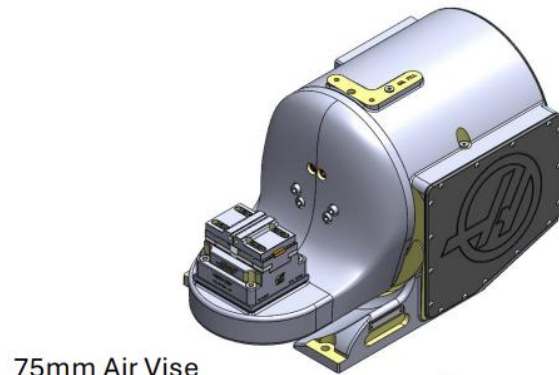

* Alternate work holding available through Haas e-com

Products and Price List Update

- Release HRT200HS in all regions

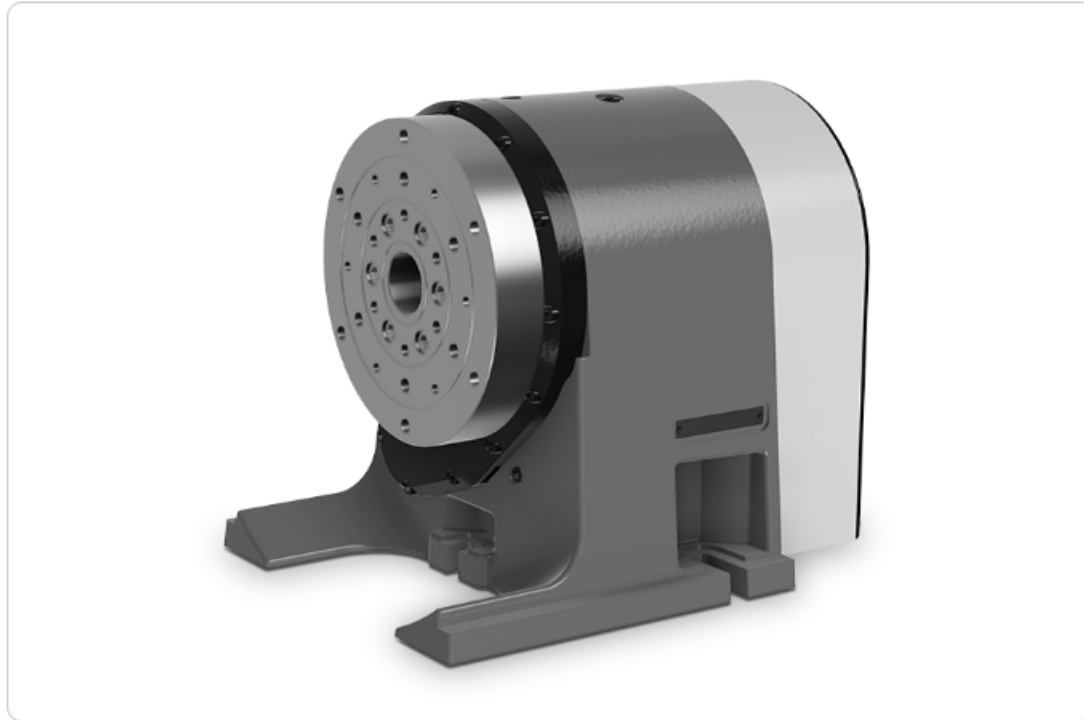

HRT200HS

Starting Price: US\$19,995

The Haas HRT200HS is a high-speed rotary table that provides 1000°/sec indexing, and allows continuous rotation for 4th-axis contouring operations.

Note: Requires a Haas mill with 4th-axis drive and **NGC software version 100.21.000.1130** or later for full 4th-axis operation. **Not available for stand-alone operation.**

- Compact design
- 1000°/sec indexing
- 105 ft-lb (142 Nm) spindle torque
- Allows continuous rotation
- Easy plug-and-play connection to Haas machines
- Industry-leading performance and capabilities

1
SPINDLES

200 mm
PLATTER SIZE

105 ft-lb
MAX TORQUE

1000 °/sec
MAX SPEED

COMPARE MACHINES

EXPLORE ALL INVENTORY [↗](#)

Products and Price List Update

- Add PALLET POOL-HMC-LG-4 option to EC-1600ZT in all regions



4+1 Pallet Pool for the EC-1600ZT

Starting Price: **US\$249,995**

Automated loading for big parts

32" x 32"
PALLET SIZE

4+1
STATIONS

PALLET POOL-HMC-LG-4 SELECTED ON EC-1600ZT

- i** 4TH-AXIS-RTY is included free with PALLET POOL-HMC-LG-4(2191)
- i** CABCOOL is included free with PALLET POOL-HMC-LG-4(2191)
- i** SMTC-70 was automatically set because of PALLET POOL-HMC-LG-4(1050)
- ⚠** Included option SMTC-50 was removed because SMTC-70 was selected(9999)

Available for order, with estimated delivery Q4 2025.

Ok

Products and Price List Update

- Release all four SMTC-120 40T/HS/HSK options **in all regions**

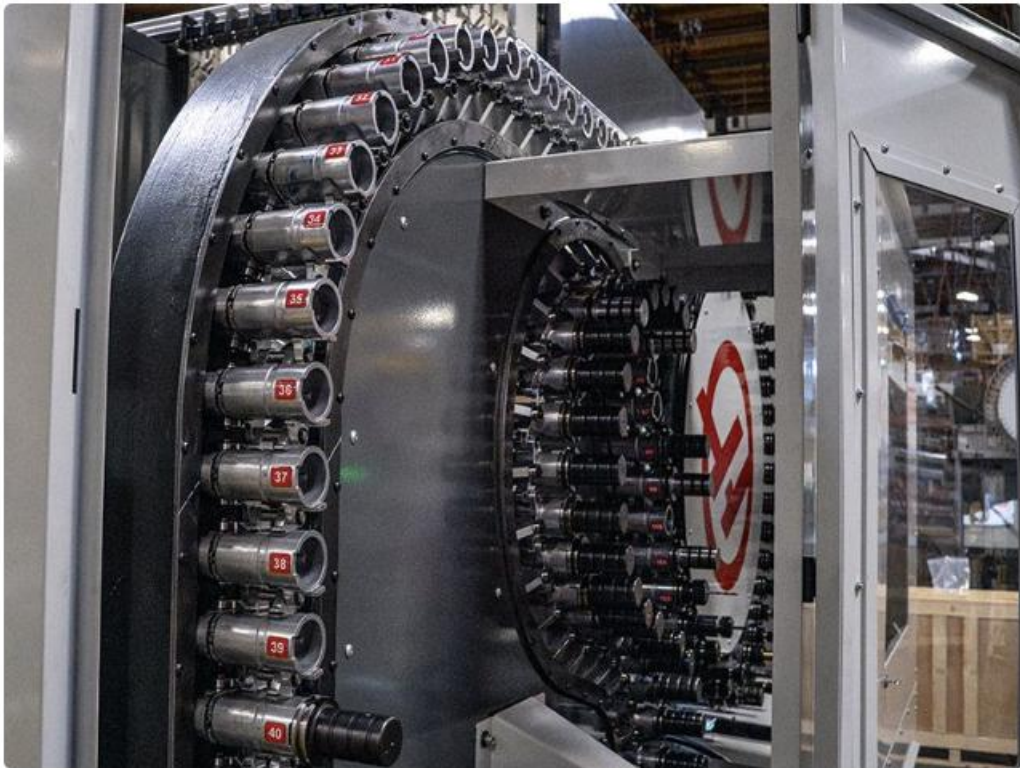

High-Speed 120+1 Side-Mount Tool Changer

*Starting Price: **US\$69,995***

High-production tool changer for UMCs

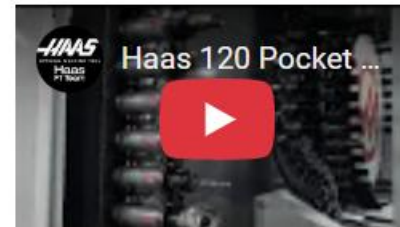

- Bi-directional servo-driven positioning for fast tool staging
- Mounts to the machine's bridge and base for stability
- High-speed tool changes reduce non-cutting time
- Tool Table allows complete control over the tool changer
- Identify tools as LARGE to leave adjacent pockets empty
- Identify tools as HEAVY to slow tool changer motion

Products and Price List Update

- Release HKM-1-CE in HE/CH



HKM-1 Knee Mill



- 32.7" x 12" x 16" (831 x 305 x 406 mm) travels
- Variable-speed 4500-rpm R8 spindle
- Pneumatic power drawbar
- X-axis power feed w/clutch handles
- XY DRO
- Digital quill scale
- Coolant system w/chip tray
- Automatic lubrication system

The Haas HKM-1 is a traditional-style knee mill with a 9" x 49" (229 x 1245 mm) table and a 4500-rpm

- Add ROBOT PKG-50KG back to the price list in US/CA/MX



Haas 50 kg Robot Package

Starting Price: US\$88,195

The Haas Robot Package-50kg is a fully integrated, plug-and-play, 50 kg capacity robot system for Haas machines. The system is controlled entirely from the Haas control. Includes: 6-axis robot, software interface for direct control through the Haas machine, electrical interface box, interface for optional area scanners or light curtains, and all necessary solenoids, hardware, and cables.

50 kg Max Capacity (part + gripper)

NOTE: Part table not included. The robot must be bolted to the floor, and requires a separate 200-230V 3-Phase, 50/60 Hz, 7.5 kVA power supply.

- All-inclusive design, with plug-and-play capabilities to Haas vertical machining centers and turning centers
- Interfaces directly with the Haas control
- Includes interface for optional area scanners or light curtains
- Single gripper included
- 50 kg capacity at wrist (part + gripper)
- No need for additional M-code outputs, or the complex PLC connections used by 3rd-party integrators
- Requires a separate 200-230V 3-Phase, 50/60 Hz, 7.5 kVA power supply

Haas Robots carry a full two-year warranty.

- Add ROBOT PKG-3 back to the price list in all regions except US/CA/MX

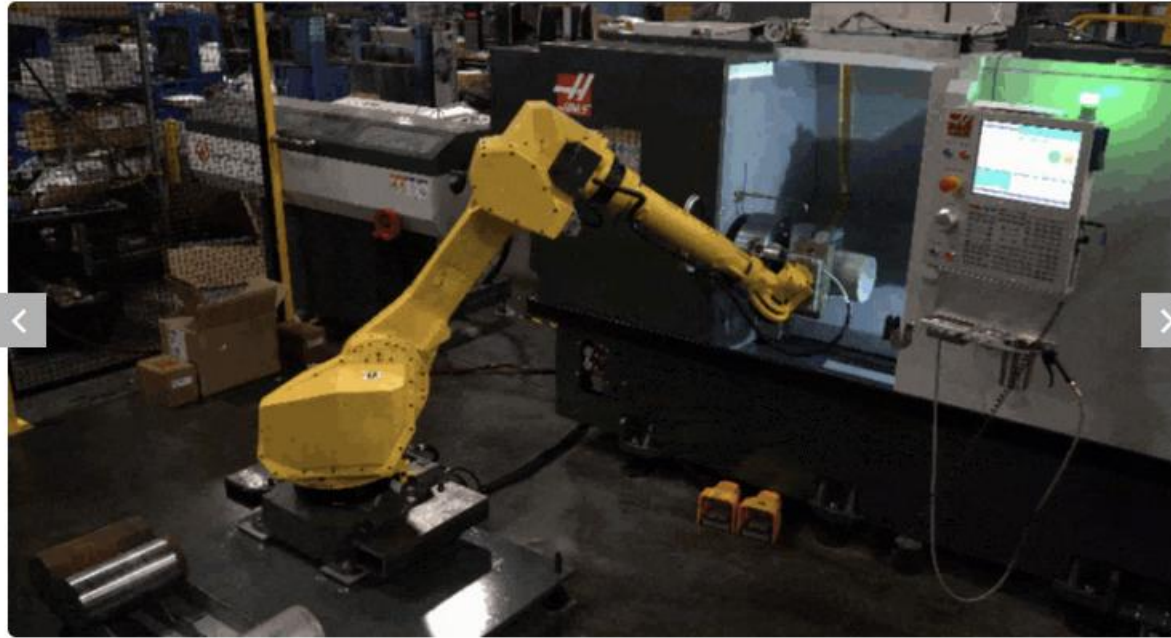

Haas Robot Package 3

Starting Price: 95.895 €

The Haas Robot Package 3 is a fully integrated, plug-and-play, 50 kg capacity robot system for Haas machines. The system is controlled entirely from the Haas control. Includes: 6-axis robot, software interface for direct control through the Haas machine, electrical interface box, safety guarding, and all necessary solenoids, hardware, and cables.

50 kg Max Capacity (part + gripper)

NOTE: Part table not included. The robot must be bolted to the floor, and requires a separate 200-230V 3-Phase, 50/60 Hz, 7.5 kVA power supply.

- All-inclusive design, with plug-and-play capabilities to Haas vertical machining centers and turning centers
- Interfaces directly with the Haas control
- Single gripper included
- 50 kg capacity at wrist (part + gripper)
- Includes CE-compliant safety guard fencing.
- No need for additional M-code outputs, or the complex PLC connections used by 3rd-party integrators
- Requires a separate 200-230V 3-Phase, 50/60 Hz, 7.5 kVA power supply

Haas Robots carry a full two-year warranty.

Products and Price List Update

- Add CAMERA MONITOR SYS option on VR-8/9/11/14 in all regions



~~HDC~~ Camera Monitor System

Standard on some models

~~Dual~~ cameras and LCD monitors to view your machining

Products and Price List Update

- Add MIST CONDENSER option on ST-20L/20LY/25L/25LY/28L/28LY/30L/30LY/35L/35LY in all regions

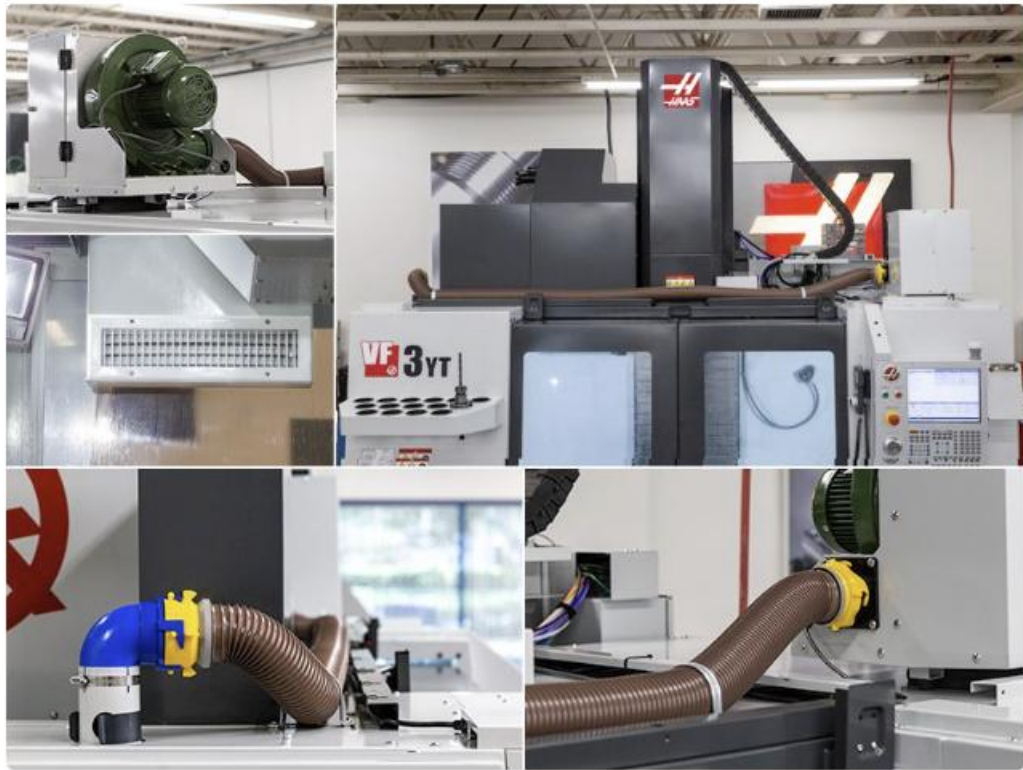

Coolant Mist Condenser

Starting Price: US\$2,995



- Complete closed-loop recirculation system; does not require venting to the outside
- Powered directly from the CNC control
- Activated by M-code within the program
- Dual mechanical filters condense the mist and return the coolant to the enclosure

Start loading parts sooner, without waiting for the coolant mist to clear from the machine enclosure. The Haas Coolant Mist Condenser keeps the machine's enclosure clear of mist and smoke generated during the machining process – reducing health risks, reducing coolant consumption, and yielding a cleaner machine and shop.

NOTE: This is not an air filtration system. It is a mechanical system that removes coolant mist from the enclosure, condenses it into liquid coolant, and returns it to the machine. If air filtration is required, aftermarket systems are available. Please contact a 3rd-party specialist to address your specific needs.



Products and Price List Update

- Add AUTO DOOR-MILL option on DC-2/40 in all regions

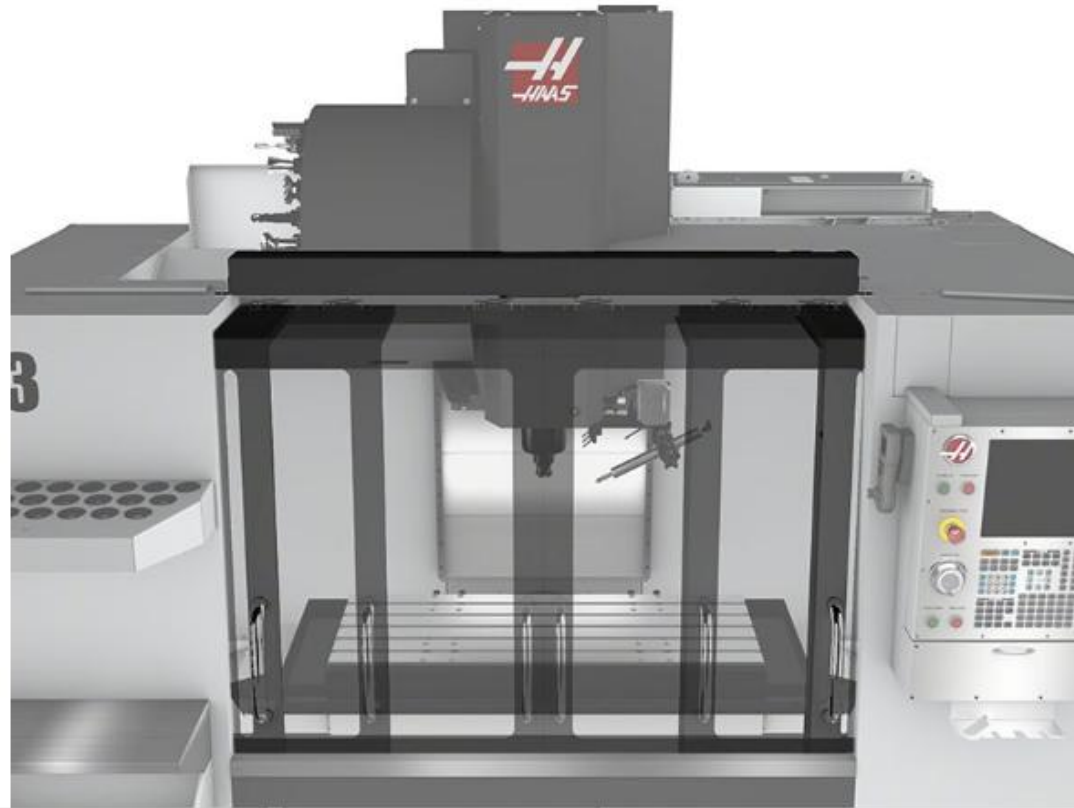

Auto Door for Mills

Starting Price: US\$2,395

Increases productivity and reduces operator fatigue

Products and Price List Update

- Add SINGLE GRIPPER-CBT30 option on COBOT PKG-30KG in all regions

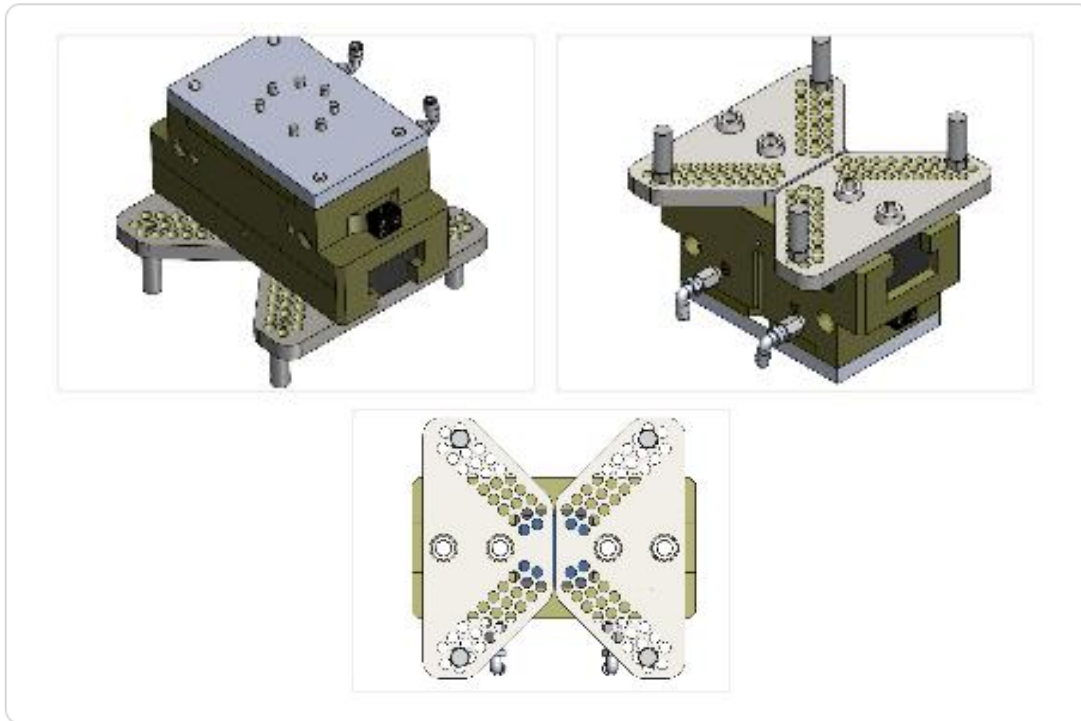

Single Gripper, HC30 Cobot

Standard on some models

Single part gripper for Haas 30 kg cobot

MAX PART WEIGHT: 50lb.

Single gripper weight: 16 lb.

Round diameter: 0.75" to 8"

Square: 0.5" to 6.5"

Products and Price List Update

- Add MULTI-STAGE CLT PUMP as standard on VS-1/3/3-5AX in all regions



Multi-Stage Coolant Pump

Standard on some models

More flow, more pressure, less noise

Products and Price List Update

- Add MULTI-STAGE CLT PUMP as standard on HDC-3-5AX when CS-GR is selected in all regions



Multi-Stage Coolant Pump

Standard on some models

More flow, more pressure, less noise

Products and Price List Update

- HDC-3-5AX: add 10K-HSK-A100 option

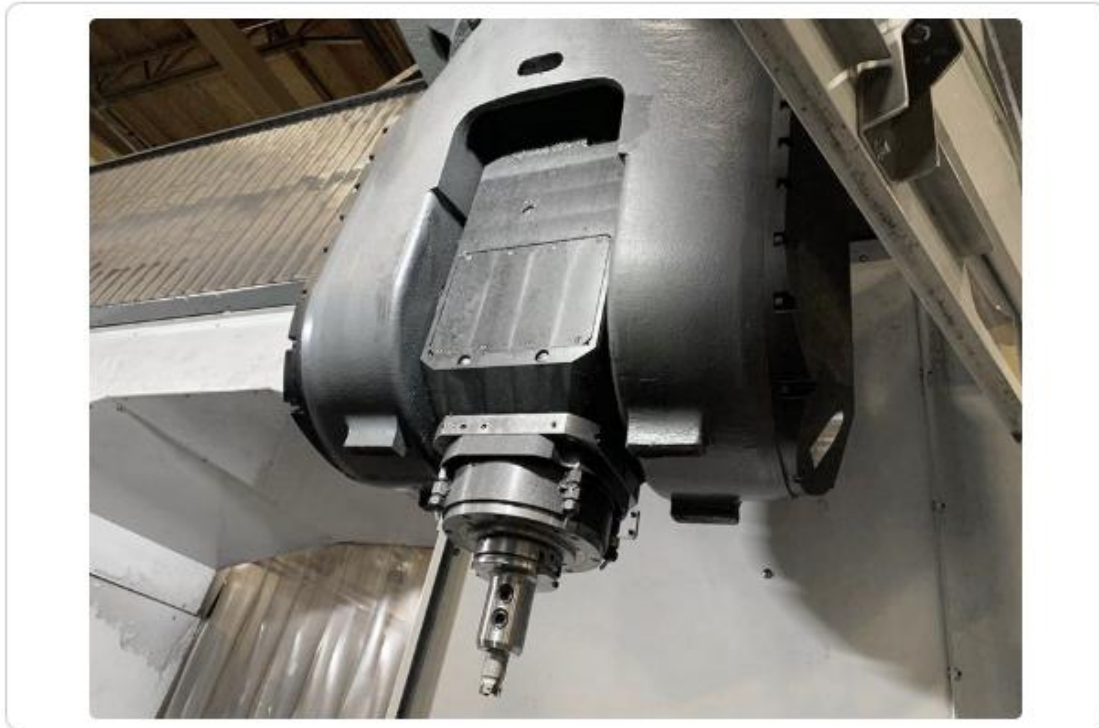

10,000-rpm Spindle, HSK-A100

Starting Price: US\$19,995

High-speed spindle for the HDC-3-5AX

10k
SPEED

HSK-A100
TAPER

45 hp
POWER

Integral Motor
DRIVE

Products and Price List Update

- Add AUTO OPERATOR WINDOW as standard on HDC-3/3-5AX and GM-1/1XT in all regions



Products and Price List Update

- Remove AUTO WINDOW-DC from being an option on DC-3/40 and DC-4/40 in all regions

DC-3/40 Drill Center Build-&-Price

Current Configuration		AUTO WINDOW FOR DC SERIES	US\$50/mo
Spindles		DETAILS >	US\$2,995 

Products and Price List Update

- Remove ROUTER SOFTWARE PKG option from SR-3015/3015P/3015P-4AX/4020/4020P in all regions

The Haas Control

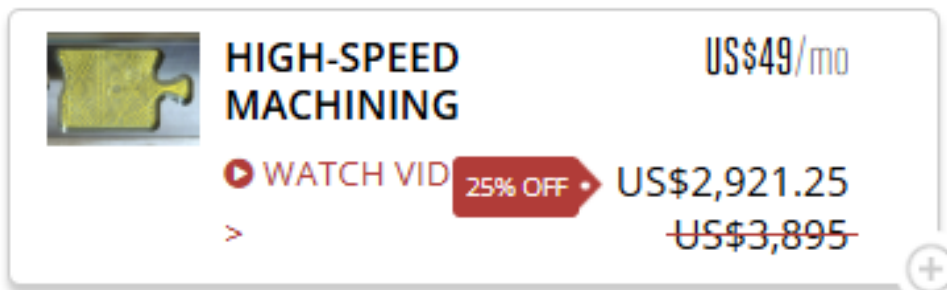

A product card for 'HIGH-SPEED MACHINING'. It features a small image of a yellow puzzle piece on the left. The text includes 'HIGH-SPEED MACHINING' in bold, 'US\$49/mo' in the top right, and a price of 'US\$2,921.25' with a '25% OFF' badge and a strikethrough price of 'US\$3,895' below it. There is a 'WATCH VID' button with a play icon and a right-pointing arrow, and a plus sign in a circle at the bottom right.

- Standard [Control Widescreen Monitor](#)
- Standard [Large Remote Jog Handle with Touchscreen Display](#)
- Standard [Ethernet Interface](#)
- Standard [WiFi Connection for the Haas Control](#)
- Standard [Power Surge Protection](#)
- Standard [Advanced Tool Management](#)
- Standard [Media Display M-Code; M130](#)
- Standard [HaasConnect: Remote monitoring](#)
- Standard [HaasDrop](#)
- Standard [Visual Part Programming System](#)
- Standard [Spindle Orientation](#)
- Standard [User-Definable Macros](#)
- Standard [Coordinate Rotation and Scaling](#)**
- Standard [Standard Program Memory, 1 GB](#)

Video Update

Video Update

Recently Released Videos

- Haas Laser Marker Rotary Part Marking Options - HaasTooling.com
- https://www.youtube.com/watch?v=4XRndO_eJt8
- Customer Spotlight - American Torch Tip Co. - Haas Automation, Inc.
- <https://www.youtube.com/watch?v=4Y23Am34gto>
- Laser Mark Your Parts Easily! - The Haas HL-50E Laser Marking Machine - Haas Automation, Inc. - <https://www.youtube.com/watch?v=nPCQm6agORY>

Video Update

Recently Released Videos

- Haas Laser Marker Rotary Part Marking Options - HaasTooling.com
- https://www.youtube.com/watch?v=4XRndO_eJt8

Haas Tooling Video

- Informative video
- Accessories for HL-50E
- Just added to Price List
- Super Affordable
- Simple Interface
- Standard on all HL-50E units
- Visit all users
- Roller Style – Long Shafts
- 80mm Chuck – Shorter Pieces
- Share it as needed

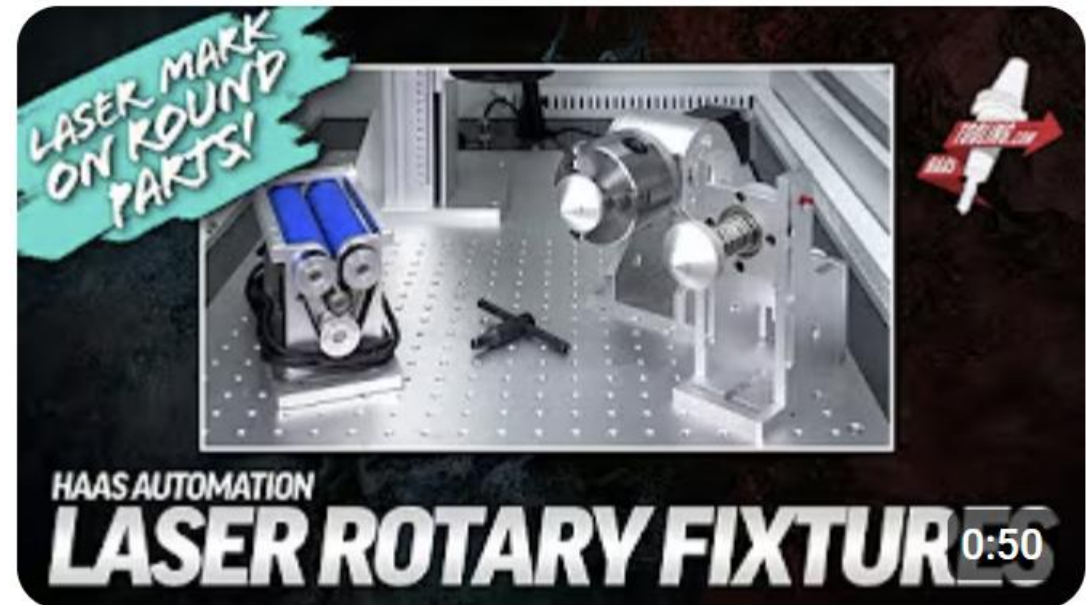

Video Update

Recently Released Videos

- Customer Spotlight - American Torch Tip Co. - Haas Automation, Inc.
- <https://www.youtube.com/watch?v=4Y23Am34gto>

Customer Spotlight Video

- Resides on Automation Page
- Robot Loading
- APL Loading
- Highlighted in Success w/
Automation Presentation *
- 24 hrs./day – 5.5 days/wk.
- Increased Production by 250%



- * - <https://sales.haascnc.com/presentation/success-automation>

Video Update

Recently Released Videos

- Laser Mark Your Parts Easily! - The Haas HL-50E Laser Marking Machine - Haas Automation, Inc. - <https://www.youtube.com/watch?v=nPCQm6agORY>

Haas Tooling Video

- Informative video
- Features of HL-50E
- Basic Specs
- Work Area Details (2:10)
- Various Applications
- Overview of Software
- Check it out
- Share it as needed



Tooling Update

FREEDOM SALE
TOOLING.COM
HAAS
SHOP NOW!

7500+
HIGH-QUALITY TOOLS AT LOW PRICES

FREE NEXT-DAY DELIVERY!
Sign up for WINNER'S CIRCLE
~~\$95~~ **\$10** FOR A YEAR!

The banner features a red and blue background with a stylized eagle. The text 'FREEDOM SALE' is in large white letters with a red outline. Below it, 'TOOLING.COM' and 'HAAS' are written in smaller white letters. A red arrow points to the right. The number '7500+' is in large white letters with a red outline. Below it, 'HIGH-QUALITY TOOLS AT LOW PRICES' is written in white. On the right, 'FREE NEXT-DAY DELIVERY!' is in yellow, 'Sign up for WINNER'S CIRCLE' is in red, and '~~\$95~~ \$10 FOR A YEAR!' is in white and red. A red truck icon is next to the price.

WINNER'S CIRCLE Update

Still On Sale - Only \$10 – 90% off the already reduced price

Over 10,000 Subscriptions and Growing

Tooling Update, Global Except Europe & China



Tool Tray

9 items



Apparel

17 items



Quick-Change Collet Chucks

30 items

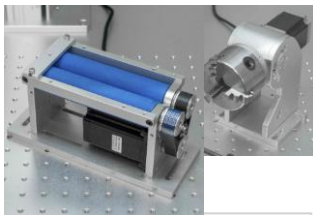

Laser Marking Machines

8 items



ER Collet Chucks

90 items

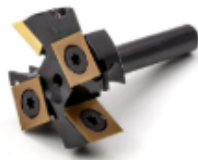

Indexable CNC Router Bits & Inserts

6 items

+93 Items

- ER Collet Racks
- Haas Apparel
- Lathe Collet Chuck Kits
- Laser Rotary Fixture
- ER Collet Chuck
- CNC Router Bit
- Scroll Chuck for 5C Indexer

SHOP NOW!
TOOLING.COM
HAAS

3000+
HIGH-QUALITY TOOLS AT LOW PRICES

FREE EXPRESS DELIVERY!
Sign up for Winner's Circle **10€ FOR A YEAR!** ~~95€~~

WINNER'S CIRCLE Update

Still On Sale - Only €10 – 90% off the already reduced price

Over 10,000 Subscriptions and Growing

HAE - Tooling Update



Cutting Tool Sharpeners

1 items



Tool Tray

7 items



Spindle Reduction Sleeves / Liners

39 items



5C Indexer Chucks

1 items

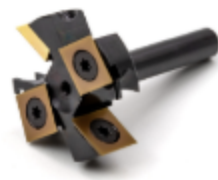

Indexable CNC Router Bits & Inserts

6 items



Quick-Change Collet Chucks

22 items

+33 Items

- Drill Bit Sharpener
- ER Collet Racks
- Spindle Liner Kits
- Scroll Chuck for 5C Indexer
- CNC Router Bit
- Lathe Collet Chuck Kits
- TL/CL Turret holder/kits

Marketing Update



WOP
VALUE OPTION PACKAGES
**A NEW WAY
TO SAVE**

LEARN MORE

This advertisement features the letters 'WOP' in a large, bold font. The letter 'O' is replaced by a circular image of a Haas tool bit. Below the main text, there is a red button with the text 'LEARN MORE'.



SHOP NOW!
FREEDOM SALE
HAAS TOOLING

7500+
HIGH-QUALITY TOOLS AT LOW PRICES

FREE NEXT-DAY DELIVERY!
Sign up for WINNER'S CIRCLE **\$10** FOR A YEAR! ~~\$35~~

SHOP HAAS TOOLING

This advertisement has a red and blue background with a stylized eagle. It features the text 'FREEDOM SALE HAAS TOOLING' at the top, 'SHOP NOW!' in yellow, and '7500+' in large white numbers with circular images of tools inside. Below that is 'HIGH-QUALITY TOOLS AT LOW PRICES'. At the bottom, it says 'FREE NEXT-DAY DELIVERY!' and 'Sign up for WINNER'S CIRCLE \$10 FOR A YEAR! \$35'. A black button at the bottom left says 'SHOP HAAS TOOLING'.

FLASH SALE



NEW PRICE DROPS!

GET 25% OFF - SAVE \$44K
SPECIALLY CONFIGURED DC-4 DRILL CENTERS



[View Details | Get Quote](#)

NEW PRICE DROPS!

SAVE 25% OFF ALL
HAAS SHEET ROUTERS



[LEARN MORE](#)

NEW PRICE DROPS!

\$19,995 - SAVE \$6,000!
ON HAAS KNEE MILLS



[LEARN MORE](#)

Marketing Update

DC-1 & DC-2 MODELS



SAVINGS UP TO
\$20K OFF
BASE PRICE MACHINES

OR SAVE UP TO
25% OFF
IN-STOCK MACHINES

DC-1
30-TAPER DRILL CENTER

\$15K OFF

+ UP TO 25% OFF IN-STOCK MACHINES



LEARN MORE

DC-2
30-TAPER DRILL CENTER

\$20K OFF

+ UP TO 25% OFF IN-STOCK MACHINES



LEARN MORE

DC-1/40
40-TAPER DRILL CENTER

\$15K OFF

+ UP TO 25% OFF IN-STOCK MACHINES



LEARN MORE

DC-2/40
40-TAPER DRILL CENTER

\$20K OFF

+ UP TO 25% OFF IN-STOCK MACHINES



LEARN MORE

* 7/15/25 – New VC-400SS Flash Sale!!! (see website for details)

Marketing Tools

View Edit Track Devel

*** All images are clickable ***



[HAAS TOOLING HOME PAGE](#)

[Haas Tooling Promo page](#)

[How to redeem Online Tooling Promos](#)

[2025 AVAILABLE DIGITAL MARKETING CAMPAIGNS and MODEL GUIDES, PDFs, CATALOGS](#)

*Check Marketing Campaign page for info about HFO Demo Day.

Tooling Kits Explained (08/PCK/EK)

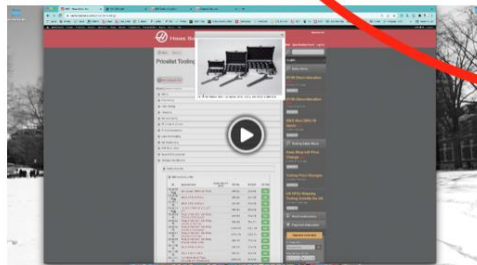

FINANCING RATES *NEW

CNCA Financing Rates are **Extended to June 30, 2025.**

Available for: US, Canada, HAE (Denmark, Germany, France, Spain, Portugal, Belgium, Luxembourg, Estonia, Latvia, Lithuania, Czech Republic, Slovenia, Slovakia, and Greece)

Date updated: May 30, 2025

Rates Chart

Effective June 1, 2025	Skip Days	Changed from May 2025						
		12	24	36	48	60	72	84
10%		0.00%	1.99%	2.99%	3.99%	4.49%		
20%		0.00%	0.99%	1.99%	2.49%	3.99%	4.99%	5.49%
25%		0.00%	0.00%	0.99%	1.99%	2.99%	4.49%	4.99%
30%		0.00%	0.00%	0.00%	0.99%	2.49%	3.99%	4.49%
40%					0.00%			
20%	90		1.49%	1.99%	3.49%	4.99%	5.49%	5.99%

Term	RATE FACTORS							
	12	24	36	48	60	72	84	
10%	0.08333	0.04254	0.02077	0.02758	0.01864			
20%	0.08333	0.04210	0.02864	0.02191	0.01842	0.01611	0.01437	
25%	0.08333	0.04167	0.02821	0.02170	0.01797	0.01587	0.01413	
30%	0.08333	0.04167	0.02778	0.02156	0.01775	0.01565	0.01390	
40%				0.02083				
20%	90		0.04243	0.02874	0.02249	0.01903	0.01649	0.01475

RATES CHART

[Rates PDF for US Customers #](#)
(Updated May 30, 2025)

[Rates PDF for HAE Customers #](#)
(Updated May 30, 2025)

US CUSTOMER FINANCING PDF

HAE Customer Financing PDF

- VALUE OPTION PACKAGES
- PROMOTIONS
- NEW PRODUCTS
- GENERAL & MACHINE
- TOOLING
- PDFS AND BROCHURES

VALUE OPTION PACKAGES (VOP) *NEW

Date updated: May 19, 2025

VF-1(SS) TO VF-5(SS)

VALUE OPTION PACKAGE COMPARISON CHART

CATEGORY: VF-1 (SS) TO VF-5 (SS)

VF-2SS

VF-2SSYT

VF-3SSYT

VF-3YT/50

VF-4SS

VF-8/50*

*We will be further defining products/categories for the VOP packages in the coming days/weeks.

A - BASIC

Package A Includes:

- ✓ Chip Auger
- ✓ High-Intensity Lighting
- ✓ Programmable Coolant Nozzle
- ✓ Through-Spindle Coolant Ready

B - PRODUCTIVITY

Package B Includes:

- ✓ Chip Auger
- ✓ High-Intensity Lighting
- ✓ Programmable Coolant Nozzle
- ✓ Through-Spindle Coolant Ready
- ✓ High-Speed Machining
- ✓ Wireless Intuitive Probing System

C - 4TH AXIS

Package C Includes:

- ✓ Chip Auger
- ✓ High-Intensity Lighting
- ✓ Programmable Coolant Nozzle
- ✓ Through-Spindle Coolant Ready
- ✓ High-Speed Machining
- ✓ Wireless Intuitive Probing System
- ✓ 4th-Axis Drive and Wiring
- ✓ Auto Door
- ✓ Coolant Maintenance Package
- ✓ Coolant Refill System
- ✓ Mist Condenser
- ✓ Oil Skimmer
- ✓ Coolant Sanitizer
- ✓ WiFi Camera
- ✓ 30+1 Side Mount Tool Changer

D - TSC/SMTC

Package D Includes:

- ✓ Chip Auger
- ✓ High-Intensity Lighting
- ✓ Programmable Coolant Nozzle
- ✓ Through-Spindle Coolant Ready
- ✓ High-Speed Machining
- ✓ Wireless Intuitive Probing System
- ✓ 4th-Axis Drive and Wiring
- ✓ Auto Door
- ✓ Coolant Maintenance package
- ✓ Coolant Refill System
- ✓ Mist Condenser
- ✓ Oil Skimmer
- ✓ Coolant Sanitizer
- ✓ WiFi Camera
- ✓ 30+1 Side Mount Tool Changer
- ✓ Auxiliary Coolant Filter
- ✓ Automatic Air Gun
- ✓ Minimum Quantity Lubrication
- ✓ Through-Tool Air Blast
- ✓ Through-Spindle Coolant, 300 psi (21 bar)

D - 5TH-AXIS

Package E Includes:

- ✓ Chip Auger
- ✓ High-Intensity Lighting
- ✓ Programmable Coolant Nozzle
- ✓ Through-Spindle Coolant Ready
- ✓ High-Speed Machining
- ✓ Wireless Intuitive Probing System
- ✓ 4th-Axis Drive and Wiring
- ✓ Auto Door
- ✓ Coolant Maintenance package
- ✓ Coolant Refill System
- ✓ Mist Condenser
- ✓ Oil Skimmer
- ✓ Coolant Sanitizer
- ✓ WiFi Camera
- ✓ 30+1 Side Mount Tool Changer
- ✓ Auxiliary Coolant Filter
- ✓ Automatic Air Gun
- ✓ Minimum Quantity Lubrication
- ✓ Through-Tool Air Blast
- ✓ Through-Spindle Coolant, 300 psi (21 bar)
- ✓ 5th-Axis Drive and Wiring
- ✓ Dynamic Work Offsets and Tool Center Point Control (DWO/TCPC)
- ✓ Second Home Position
- ✓ XL Remote Jog Handle w/Touchscreen

+ UMCS 500-1000 (INCLUDING SS)

+ ST-20 TO ST-35 (2 AND Y-AXIS)

INSANE FINANCING FOR YOUR NEXT HAAS CNC

DOWN PAYMENT	CHOOSE YOUR TERM						
	12-MONTHS	24-MONTHS	36-MONTHS	48-MONTHS	60-MONTHS	72-MONTHS	84-MONTHS
10% DOWN	0.00%	1.99%	2.99%	3.99%	4.49%	N/A	N/A
20% DOWN	0.00%	0.99%	1.99%	2.49%	3.99%	4.99%	5.49%
25% DOWN	0.00%	0.00%	0.99%	1.99%	2.99%	4.49%	4.99%
30% DOWN	0.00%	0.00%	0.00%	0.99%	2.49%	3.99%	4.49%
40% DOWN	N/A	N/A	N/A	0.00%	N/A	N/A	N/A
20% DOWN + 3-MO SKIP	N/A	1.49%	1.99%	3.49%	4.99%	5.49%	5.99%
30% DOWN + 6-MO SKIP	N/A	1.99%	2.49%	3.99%	N/A	N/A	N/A

APPLY FOR FINANCING TODAY

* Financing Terms, Conditions, and Exceptions: References are to an implied interest rate under a conditional sales contract. Interest accrues during the skip period. Down payment, rate, and terms of financing are dependent upon credit approval.

Eligible businesses should have three or more years of operation under current ownership. **U.S. and Canada only.**

All programs are 10% - 40% down. Must put a minimum of 20% down to get no payments for 3 months.

Certain equipment (e.g., stand-alone Rotaries, Shop Equipment, Bar Feeders, etc.) are subject to different rates, terms, and down-payment requirements, unless financed with a machine. No prepayment penalty on any program. Not responsible for misprints or typographical errors. Offer valid on new machine orders placed from **July 1 through July 31, 2025.**

* U.S. - Don't forget to discuss Section 179 – New Tax Bill increased limit to \$2.5M

Summer Machine Sale!

UP TO **-25%**



HAAS

LEARN MORE

SHOP NOW!

HAAS TOOLING.COM



3000+

HIGH-QUALITY TOOLS AT LOW PRICES

FREE EXPRESS DELIVERY!

Sign up for Winner's Circle **10€ FOR A YEAR!** ~~95€~~

SHOP HAAS TOOLING

Machines Configured Exclusively for Europe

EU SERIES: UP TO 34% OFF

MORE CHOICES, MORE VALUE – JUST FOR EUROPE

LEARN MORE

HAE Marketing Update

Summer
Machine Sale!

UP TO
-25%

HAAS

This advertisement features a blue and yellow background with a large '-25%' discount graphic. Below the discount, there are images of various Haas machine tools. The Haas logo is prominently displayed at the bottom center.

STOCK SALE

IN STOCK & READY TO SHIP

Brand-New Hot Deals, Demo,
Pre-Owned Machines, and more!

The advertisement uses a white background with a grey wireframe pattern of machine tools. A red price tag icon with a percentage sign is positioned over a machine tool. The text is in bold, black and red fonts.

SHOP NOW!

HAAS TOOLING.COM

3000+

HIGH-QUALITY TOOLS AT LOW PRICES

FREE EXPRESS DELIVERY!

Sign up for Winner's Circle **10€ FOR A YEAR!** 95€

This advertisement has a red and blue background. It features a large '3000+' graphic where the numbers are filled with images of various cutting tools. The text is in white and yellow, with a red arrow pointing to the website URL.

EU-SERIES

Haas Lathes & Vertical Mills.
More Choices. More Value.

The advertisement shows a dark background with a red grid pattern. It features a large image of a Haas machine tool. The text is in white and yellow, with the 'EU-SERIES' title in a large, bold font.

HAE Marketing Update

5% to 30% Off!

Some DEMO Machines @ 35% & 40% Off!

- Haas Automation -

STOCK SALE

HOT DEALS

In-Stock and Ready-to-Ship Machines

Haas Hot Deal Machines are brand-new machines in stock with special pricing. These machines are currently in our inventory, and ready for immediate delivery. All Hot Deal Machines come with a full standard 1-year warranty.

SEE DEALS



DEMO & PREOWNED

Pre-owned Machines – Most pre-owned machines were used for training new machinists at schools and technical education centers and are sold as-is, with no warranty.

Demo Machines – New machines that had limited usage performing test cuts for the purpose of demonstrating the machine capabilities. Sold with a full 1-year warranty.

VIEW MACHINES



CANCELED ORDERS

Brand-New, Custom Configured Machines

Never Used!

Canceled orders, fully inspected, and ready to ship with a standard 1-year warranty. These machines have never been installed, so don't miss out on these custom configured options at unbeatable prices!

VIEW MACHINES



HAE Marketing Update

CHOOSE YOUR FINANCING

**NO MODEL
RESTRICTIONS**

**UP TO 6-MONTH SKIP
AVAILABLE**

**NO PRE-PAYMENT
PENALTIES EVER!**

LOWEST DOWN PAYMENT
10% DOWN

4,49% Interest for as Long as 60-Months.

Payments as Low as
€1.678 PER MONTH

LOWEST INTEREST
0% FOR 48 MONTHS

Requires Larger Down Payment.

Payments as Low as
€1.250 PER MONTH

LONGEST TERM
84-MONTH TERM

With Rates as Low as 4,49%*

Payments as Low as
€973 PER MONTH

Sample payments are based on a €100.000 CNC machine purchase.

SAVE €8.429 IN INTEREST!

(Based on 0,00% for 48 months, compared to lenders with similar terms at 6,66% interest.)

HAE Marketing Update

INSANE FINANCING FOR YOUR NEXT HAAS CNC

DOWN PAYMENT	CHOOSE YOUR TERM						
	12-MONTHS	24-MONTHS	36-MONTHS	48-MONTHS	60-MONTHS	72-MONTHS	84-MONTHS
10% DOWN	0,00%	1,99%	2,99%	3,99%	4,49%	N/A	N/A
20% DOWN	0,00%	0,99%	1,99%	2,49%	3,99%	4,99%	5,49%
25% DOWN	0,00%	0,00%	0,99%	1,99%	2,99%	4,49%	4,99%
30% DOWN	0,00%	0,00%	0,00%	0,99%	2,49%	3,99%	4,49%
40% DOWN	N/A	N/A	N/A	0,00%	N/A	N/A	N/A
20% DOWN + 3-MO SKIP	N/A	1,49%	1,99%	3,49%	4,99%	5,49%	5,99%
30% DOWN + 6-MO SKIP	N/A	1,99%	2,49%	3,99%	N/A	N/A	N/A

Financing terms, conditions, and exceptions: valid in Denmark, Germany, France, Spain, Portugal, Belgium, Luxembourg, Estonia, Latvia, Lithuania, Czech Republic, Slovenia, Slovakia, and Greece only. References are to an implied interest rate under a conditional sales contract. Interest accrues during the skip period. Down payment, rate, and terms of financing are dependent upon credit approval. Eligible businesses should have three or more years of operation under current ownership. All programs are 10% - 40% down. Must put a minimum of 20% down to get no payments for 3 months. **Certain equipment (e.g., stand-alone Rotaries, Shop Equipment, Bar Feeders, etc.) are subject to different rates, terms, and down-payment requirements, unless financed with a machine. No prepayment penalty on any program.*

Offer valid on new machine orders placed from 1 July through 31 July 2025.

Did You Know...



VERTICAL MILLS

- VF Series
- Universal Machines
- VR Series
- VP-5 Prismatic
- Pallet-Changing VMCs
- Mini Mills
- Mold Machines
- High-Speed Drill Centers
- Drill/Tap/ Mill Series
- Toolroom Mills
- Compact Mills
- Gantry Series
- SR Sheet Routers
- Extra-Large VMC
- Double-Column Mills**

LATHES

- ST Series
- Y-Axis Lathes
- Dual-Spindle
- Box Way Series**
- Toolroom Lathes
- Chucker Lathe
- Haas Bar Feeder V2

ROTARIES & INDEXERS

- Rotary Tables
- Indexers
- 5-Axis Rotaries
- Extra-Large Rotaries

HORIZONTAL MILLS

- 50-Taper
- 40-Taper

AUTOMATION SYSTEMS

- Mill Automation
- Lathe Automation
- Automation Models

DESKTOP MACHINES

- Desktop Mill
- Desktop Lathe
- Control Simulator

SHOP EQUIPMENT

- Bandsaw
- Knee Mills
- Manual Lathe**
- Surface Grinder
- Vertical Saw**
- Miter Saw**

POCKET MACHINES

- Pocket Mill**

QUICK LINKS

 BUILD & PRICE PRICE LIST	 IN-STOCK MACHINES
 WHAT'S NEW	 YOUR FIRST CNC

Did You Know...

- Multi-Stage Coolant Pump



Multi-Stage Coolant Pump

Standard on some models

More flow, more pressure, less noise

* Not compatible with ACF

ERROR - NO UPDATES MADE [X]

! ACF requires one of the following to be set: TSC | TSC1K(5042)

Ok

Additional/Alternate Options Needed

Auxiliary Coolant Filter also requires either

Through-Spindle Coolant, 300 psi (21 bar)

- or -

Through-Spindle Coolant, 1k

Through-Spindle Coolant, 300 psi (21 bar) has been added by default .



- Multi-Stage Coolant Pump

- Series of stacked impellers to provide more flow and higher pressure than the single-stage coolant pump
- Much quieter operation than single impeller or gear driven pump
- Built-in filtration on intake (**0.015" holes**)
- 1.5 hp, previous single-stage was 1 hp (0.75kw)
- Standard on:
 - VF, VM, DC, DT/DM-3
 - ST-30 to ST45Y, DS-30Y
- Expanding to:
 - ST-10s to ST-28s, ST-55
- Field Update Kit – 93-1001166

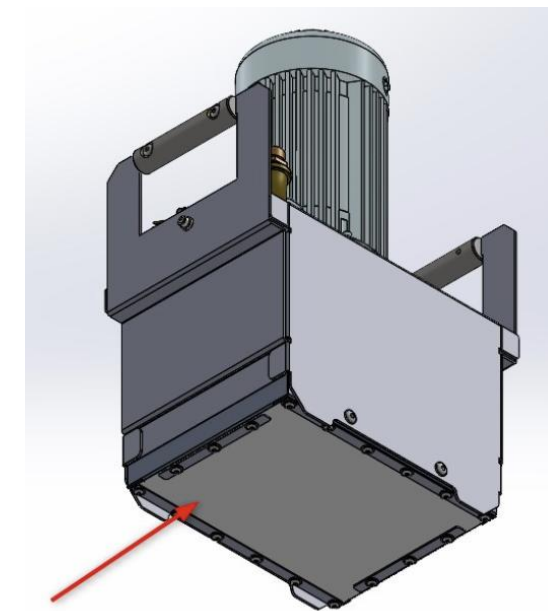

0.015" holes

- Multi-Stage Coolant Pump

- Field Update Kit - 93-1001166, \$1,495

Multi vs. Single Stage Pump

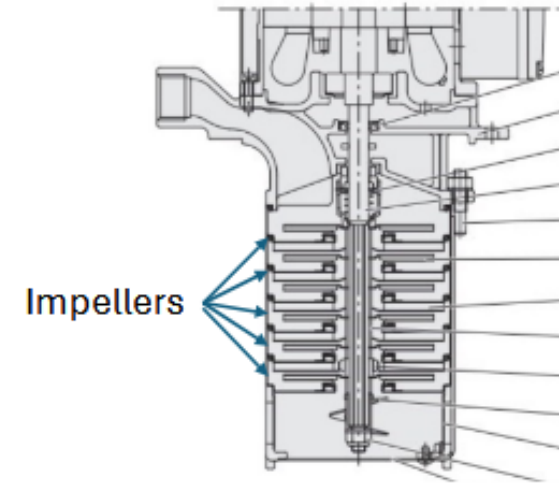
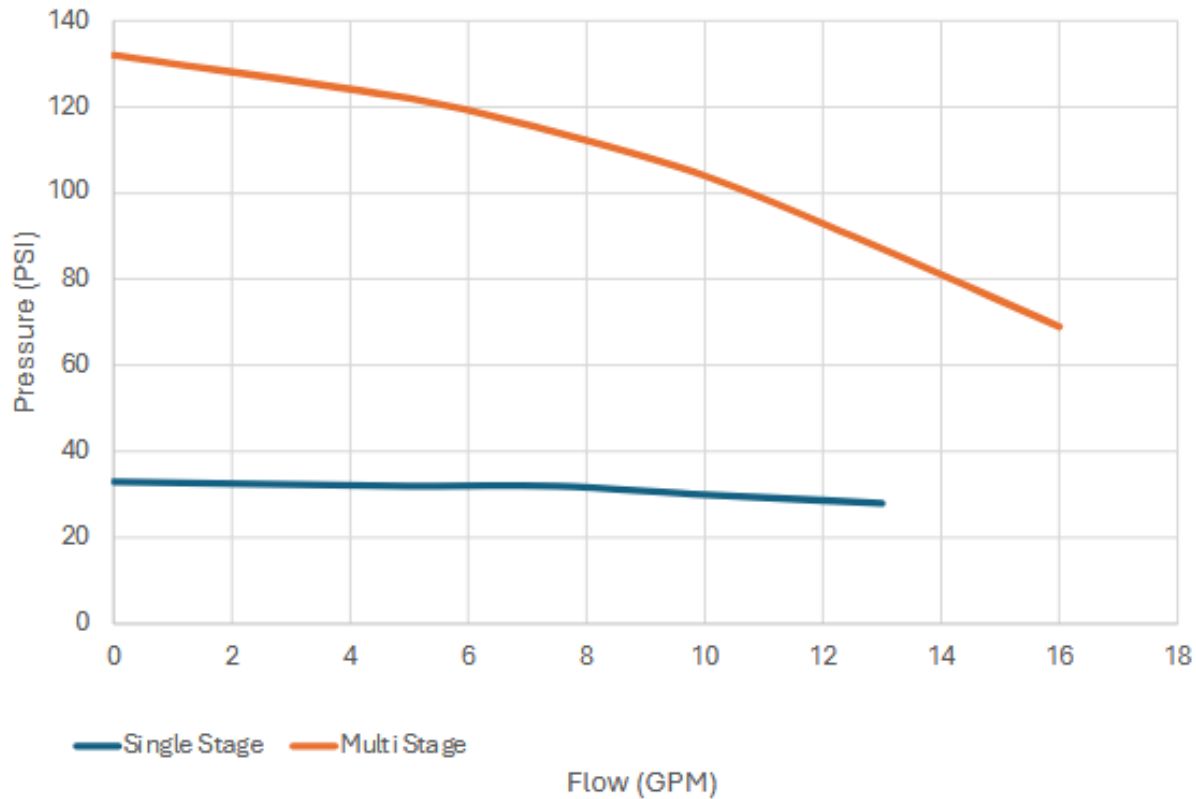

	SAE	METRIC
Power	1.5 hp	1.1 kW
Flow Rate 60Hz	16 gpm @ 70 psi	61 L/min @ 4.8 bar
Pressure 60Hz (outlet)	70 psi	4.8 bar
Pressure 60Hz (spindle)	40 psi	2.8 bar
Deadhead Pressure 60Hz	130 psi	9 bar
Flow Rate 50Hz	14 gpm @ 50 psi	53 L/min @ 3.4 bar
Pressure 50Hz (outlet)	50 psi	3.4 bar
Pressure 50Hz (spindle)	30 psi	2.1 bar
Deadhead Pressure 50Hz	95 psi	6.6 bar

Did You Know...

- New Chip Separator



- New Chip Separator

NEW Chip Separator:

- Finer mesh screen (0.015" vs 0.045")
- Coolant runs out of filter tube (allows chips to be dumped out without disassembling)
- Gauge readout to monitor pressure
- Compatible with current and older machine
- Able to withstand higher pressure from HPFC/multi-stage coolant pump
- Shipping on all machines since Q1-2025

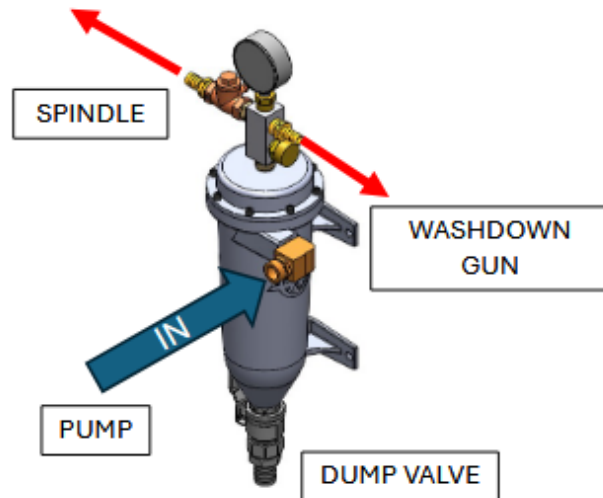

OLD Chip Separator:

- Course mesh screen (0.045" vs 0.015")
- Coolant runs inside of filter tube
- Cover has to be removed to dump out chips
- Different cap required for HPFC due to higher pressure

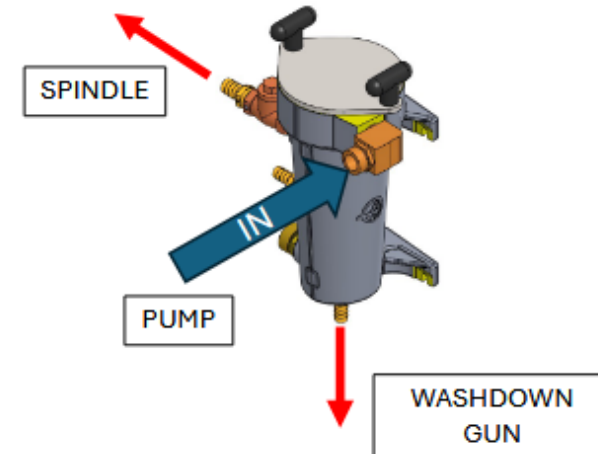

- Factory Training Dates for 2025
 - August 13/14 (was September 10/11)
 - December 3/4

Please email Scott Gasich directly with any names, email addresses and job functions for those who will be attending



THANK YOU!
FOR ALL YOUR EFFORTS



HMAS

