

All dimensions based on stackup of sheetmetal, subject to variation of 1/2" ( 13 mm)

Air & Power

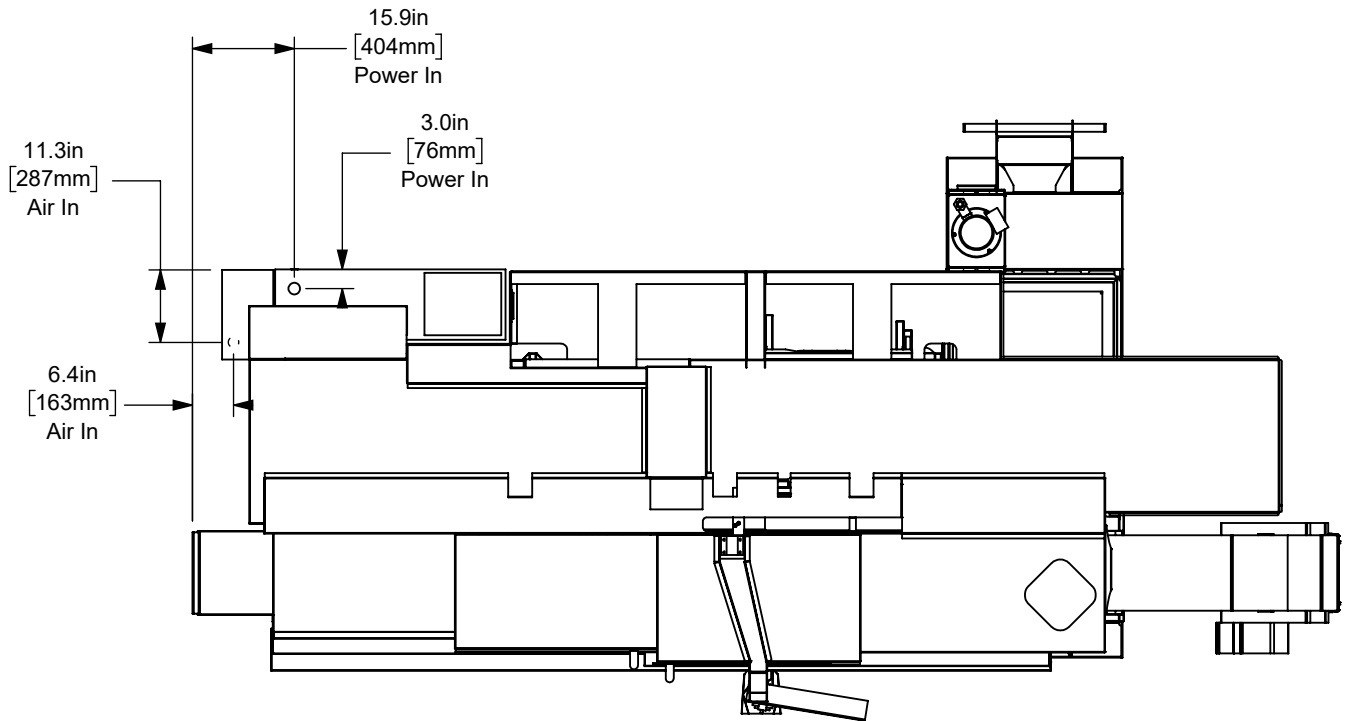

**Top View**

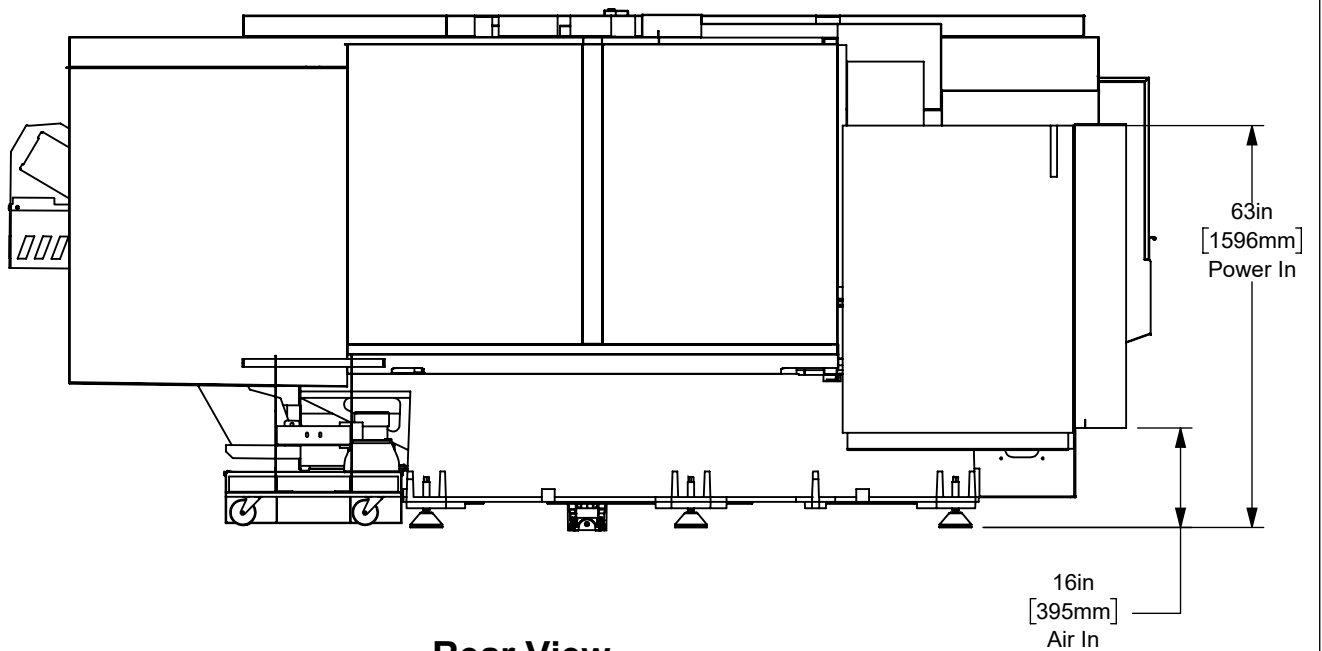

**Rear View**

All dimensions based on stackup of sheetmetal, subject to variation of 1/2" ( 13 mm)

Height Breakdown

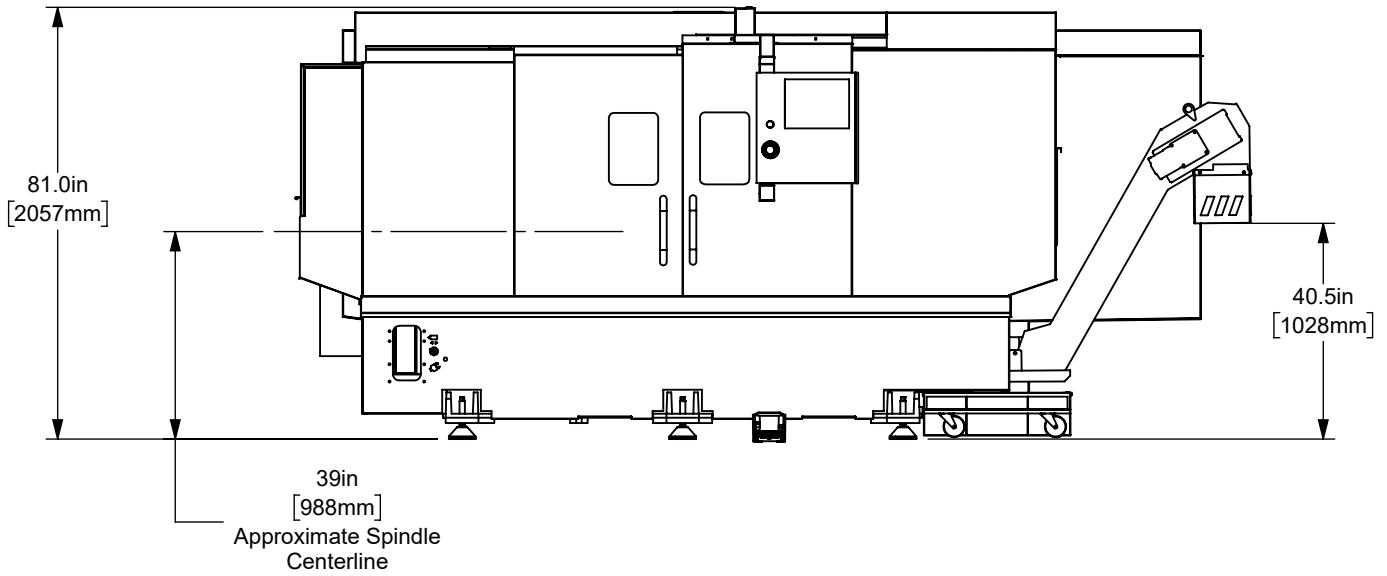

All dimensions based on stackup of sheetmetal, subject to variation of 1/2" ( 13 mm)

Width Breakdown

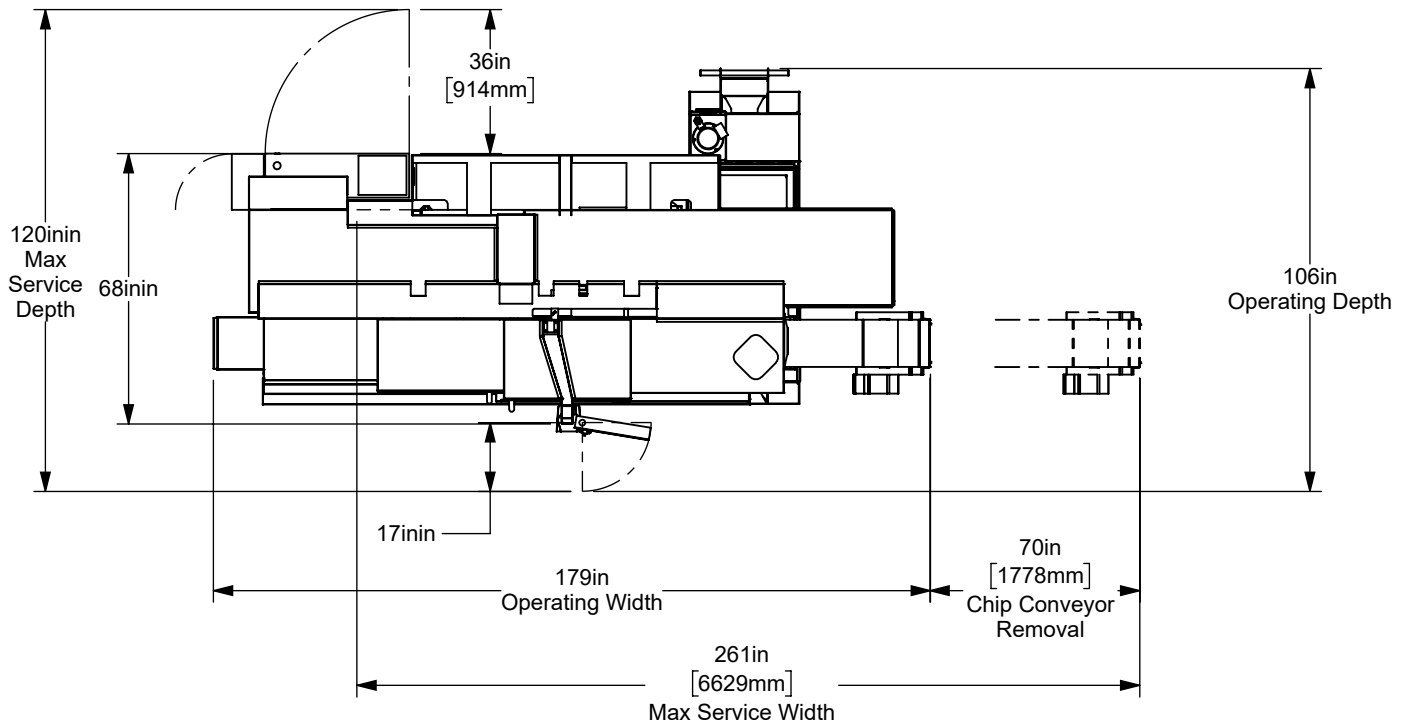

All dimensions based on stackup of sheetmetal, subject to variation of 1/2" ( 13 mm)

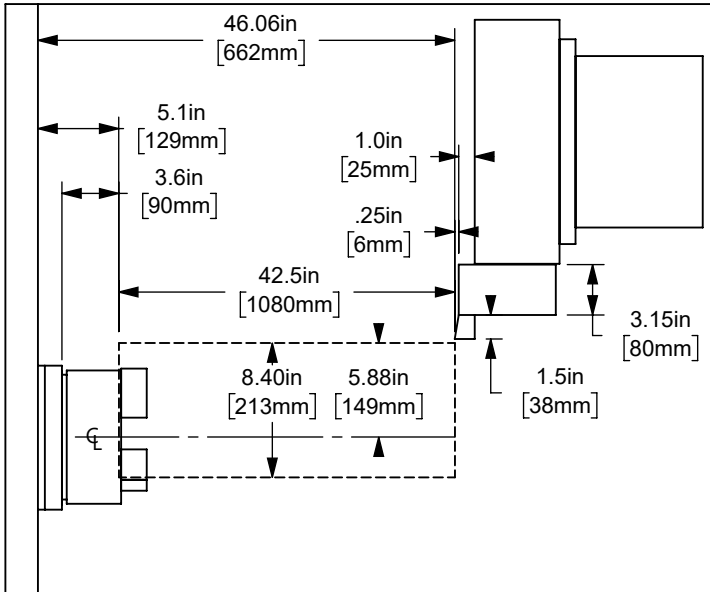

BMT OD

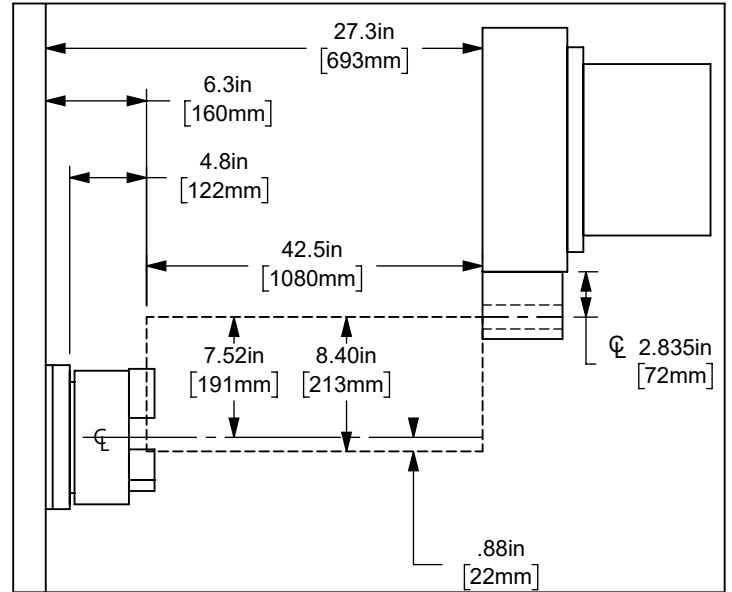

BMT ID / Drill / Bore \*\*

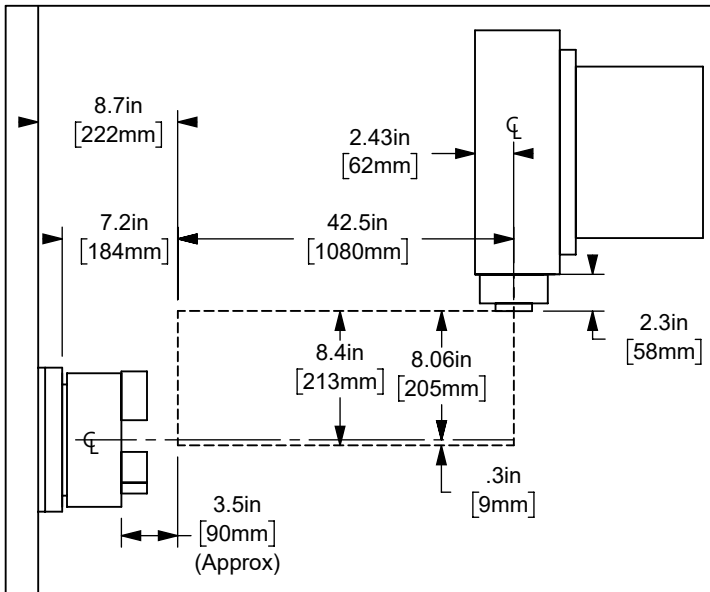

BMT Live Cross Tool \*

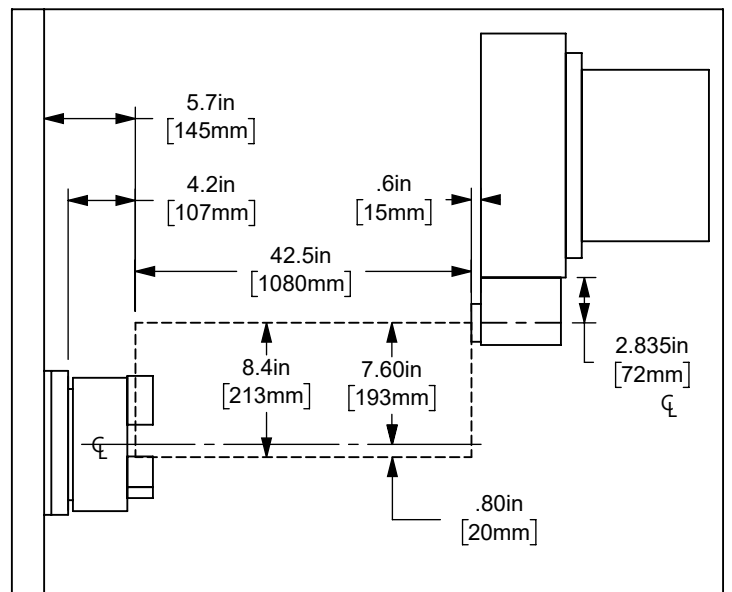

BMT Live Face Tool \*\*

\* Shift the work envelope in X by the tool protrusion length

\*\* Shift the work envelope in Z by the tool protrusion length

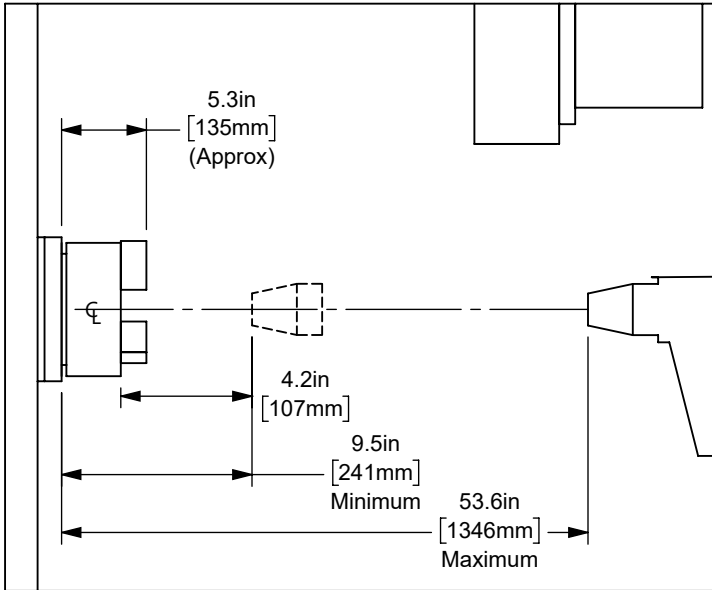

Tailstock Option

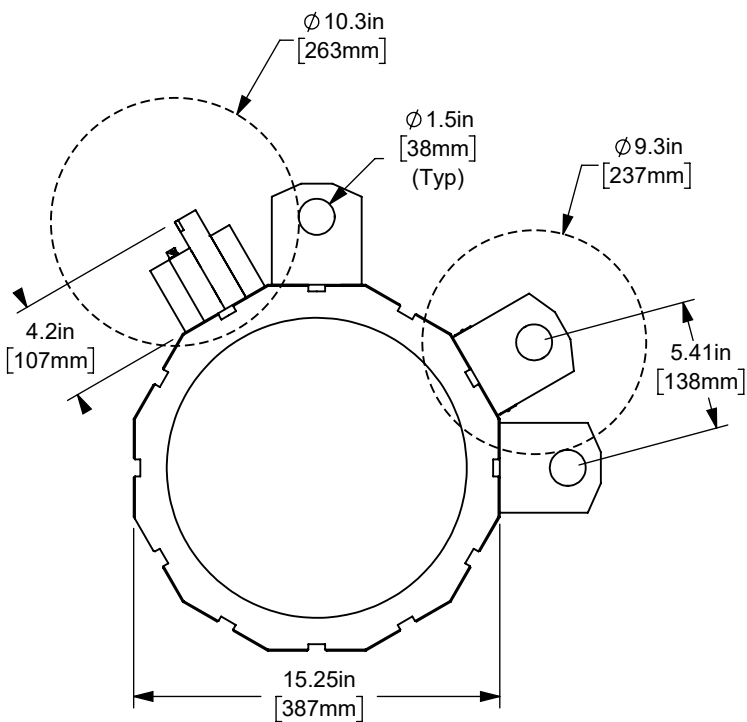

BMT65 Basic Tool Clearance

Maximum Turret Swing  $\varnothing 32.0in$  [889mm]

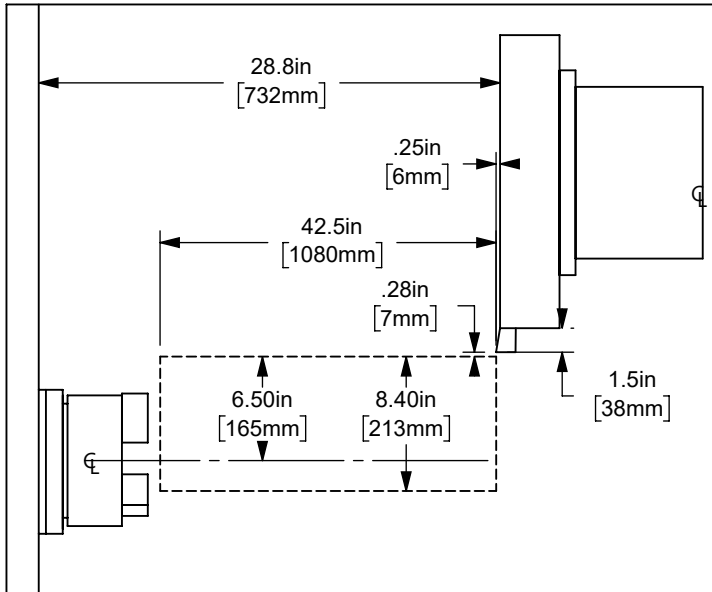

BOT OD\*

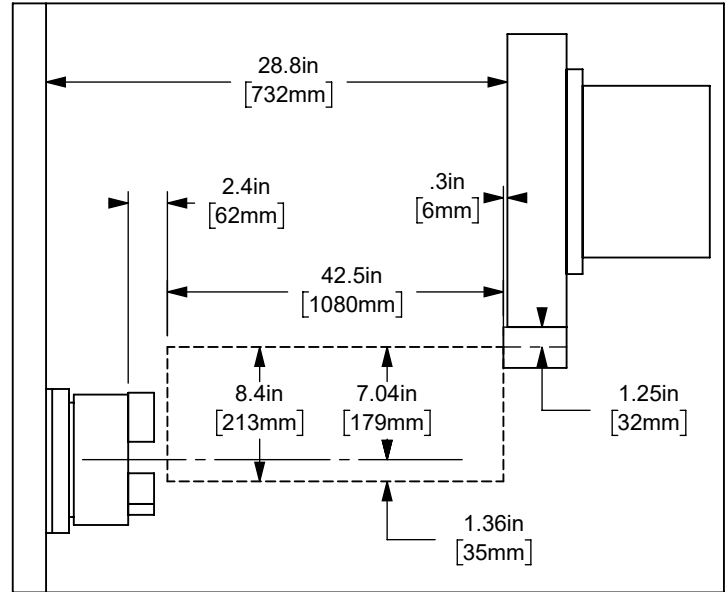

BOT ID / Drill / Bore \*/\*\*

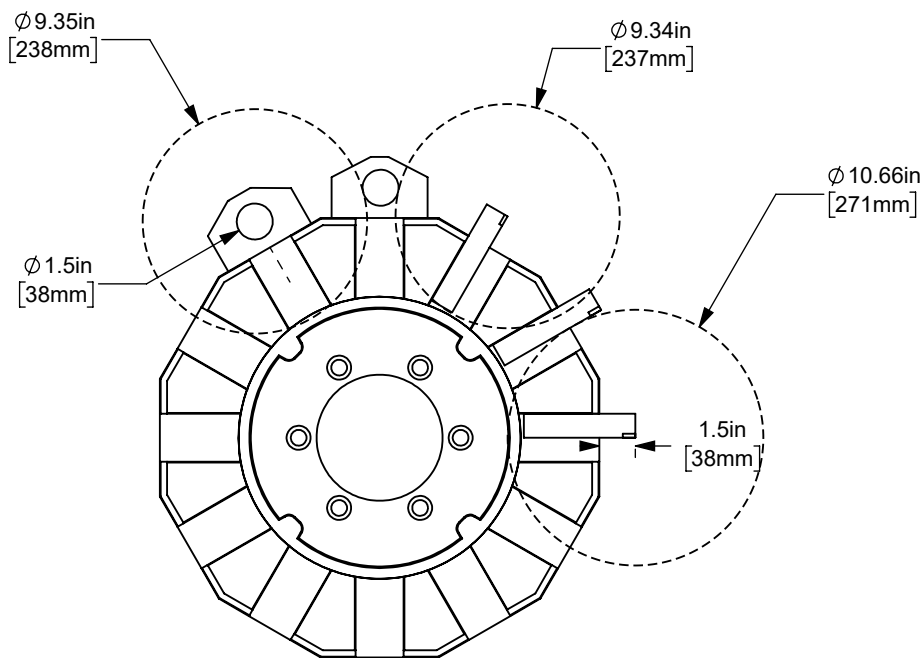

\* Shift the work envelope in X by the tool protrusion length

\*\* Shift the work envelope in Z by the tool protrusion length

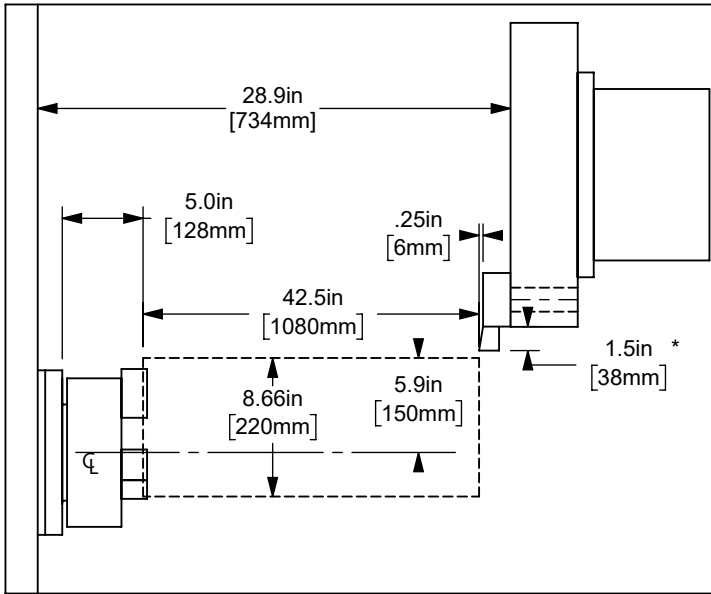

VDI OD Short\*

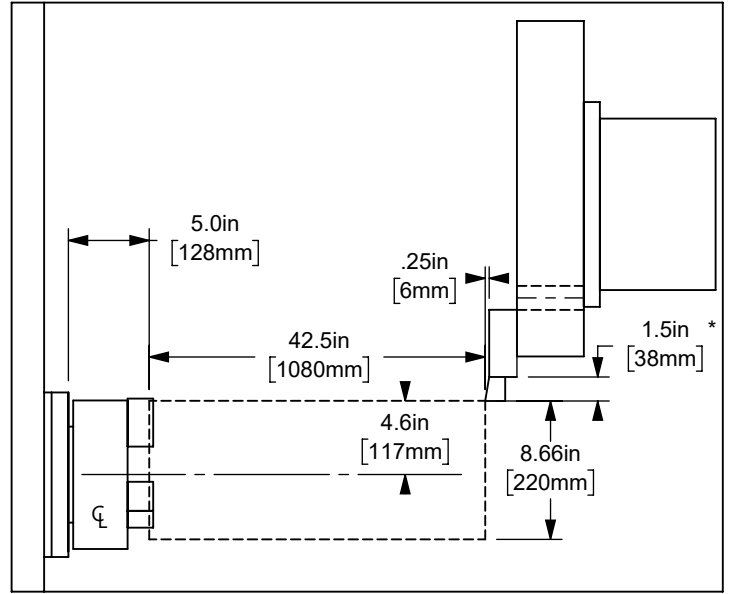

VDI OD Long\*

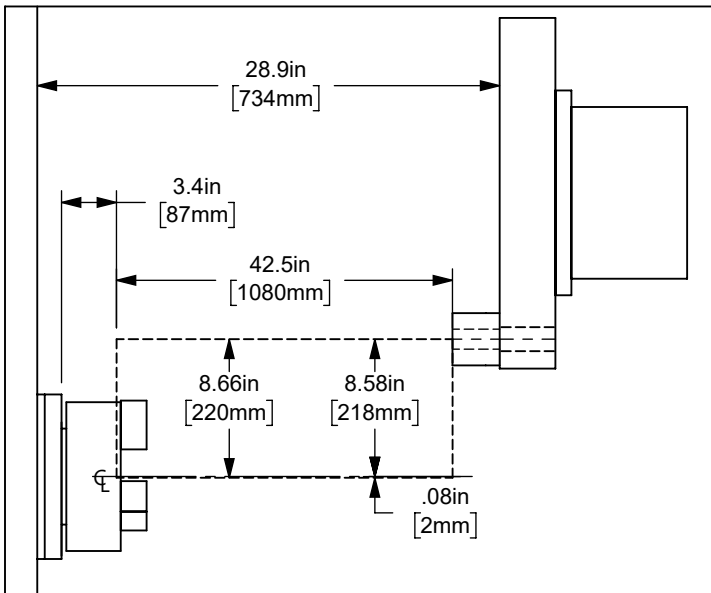

VDI ID \*\*/\*\*

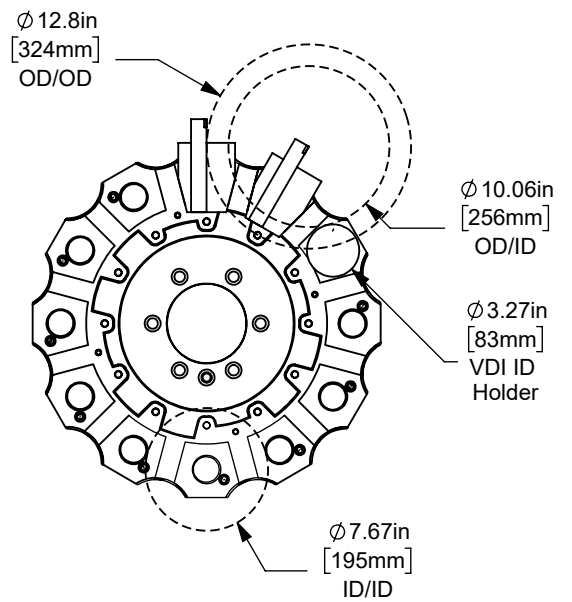

VDI Max Swing  $\varnothing$  28.0in [711mm]

\* Shift the work envelope in X by the tool protrusion length

\*\* Shift the work envelope in Z by the tool protrusion length

# Bar Feeder Layout

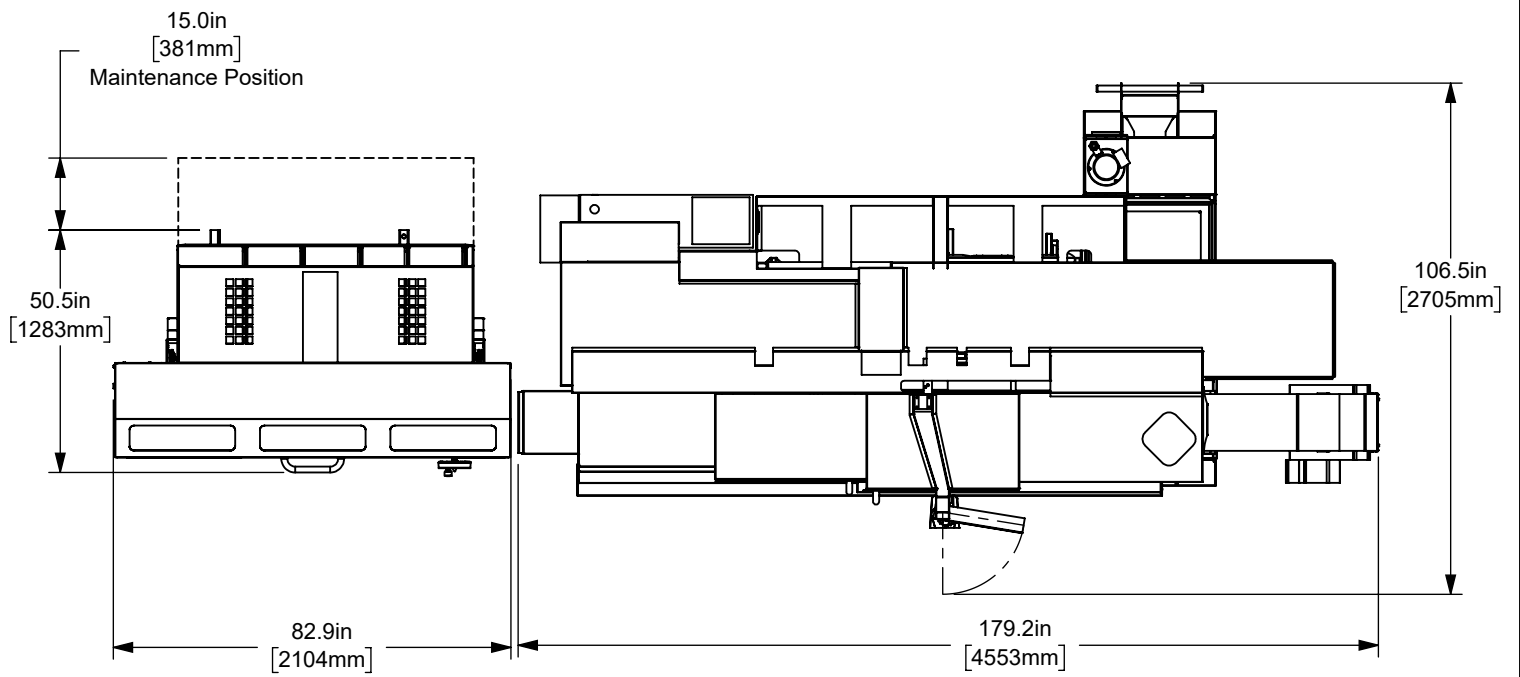

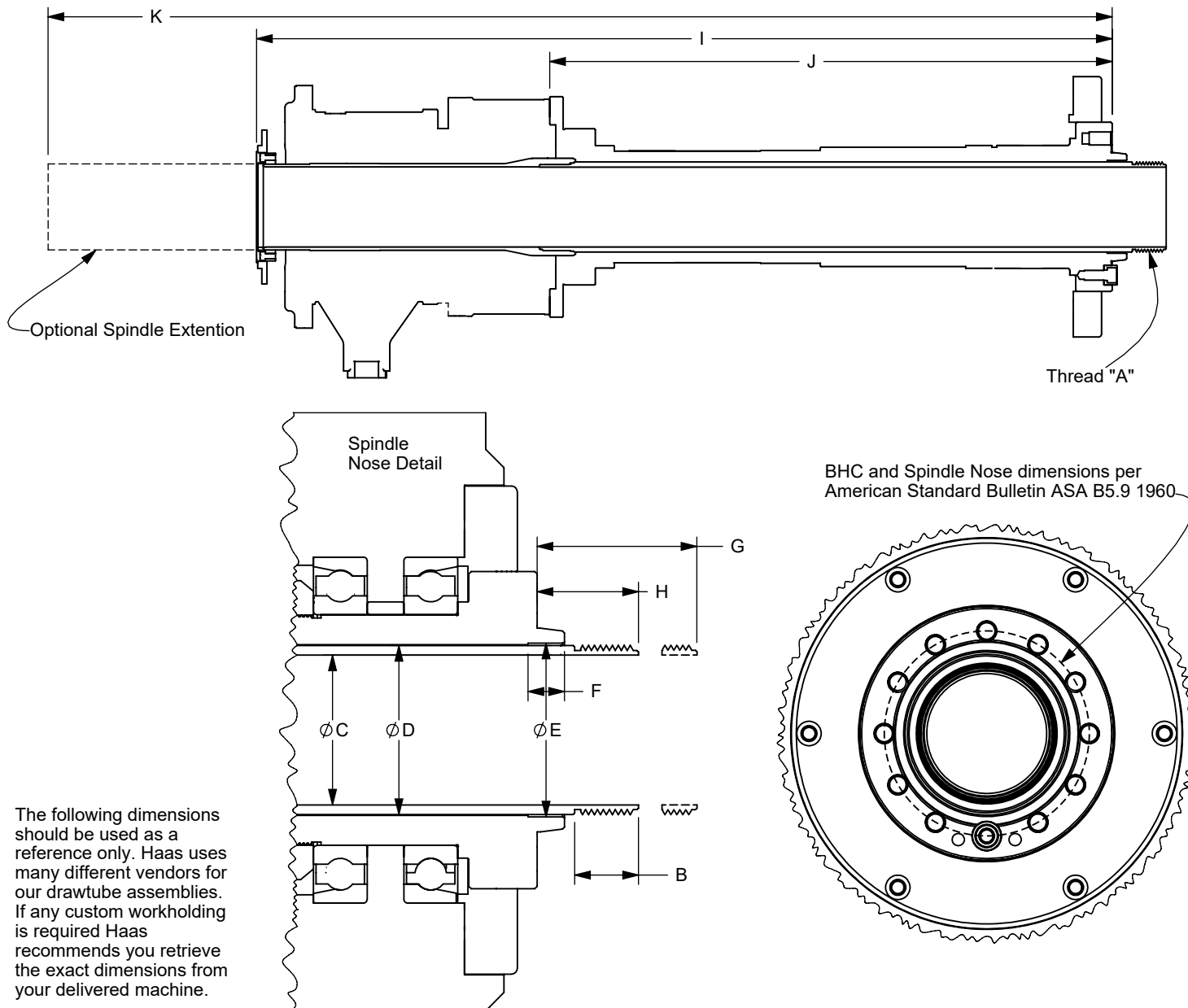

ST-20/25/Y Reboot Spindle Schematic (For ST-20/Y built after May 2019 and all vintage ST-25/Y)

DESCRIPTION	DIMENSION	ST-20/Y		ST-25/Y	
		SAE	METRIC	SAE	METRIC
MAIN OR SUB SPINDLE & TYPE		Main / A2-6		Main / A2-6	
DIAMETER OF THREAD	A	2.953"	75 MM	3.346"	85 MM
THREAD PITCH	A	0.0787"	2.0 MM	0.0787"	2.0 MM
INTERNAL OR EXTERNAL	A	External		External	
LENGTH OF THREAD	B	1.360"	34.5 MM	1.43"	36.3 MM
DRAWTUBE INTERNAL DIAMETER	C	2.560"	65 MM	3.06"	77.7 MM
DRAWTUBE EXTERNAL DIAMETER	D	2.960"	75.18 MM	3.50"	88.9 MM
COUNTERBORE INTERNAL DIAMETER	E	3.560"	90.4 MM	3.560"	90.4 MM
COUNTERBORE DEPTH	F	0.750"	19.05 MM	0.750"	19.05 MM
DRAWTUBE EXTENDED	G	2.5"	63.5MM	2.75"	69.8MM
DRAWTUBE RETRACTED	H	1.375"	35MM	1.615"	41MM
SPINDLE FACE TO BACK OF UNION	I	31.50"	800 MM	31.50"	800 MM
SPINDLE FACE TO UNION ADAPTOR	J	22.25"	565 MM	22.00"	558 MM
TO BACK OF EXTENTION (OPTION)	K	48.0"	1219MM	48.0"	1219MM

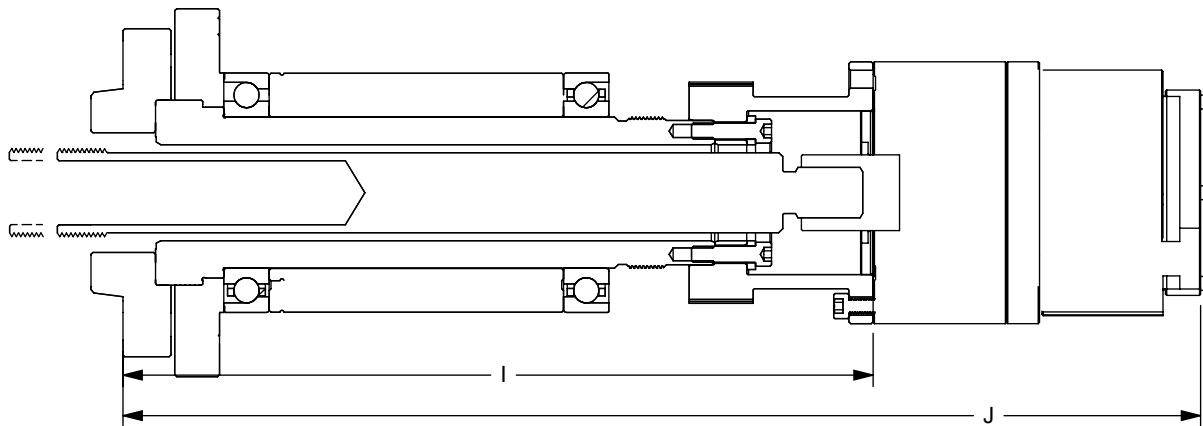

BHC and Spindle Nose dimensions per  
American Standard Bulletin ASA B5.9 1960

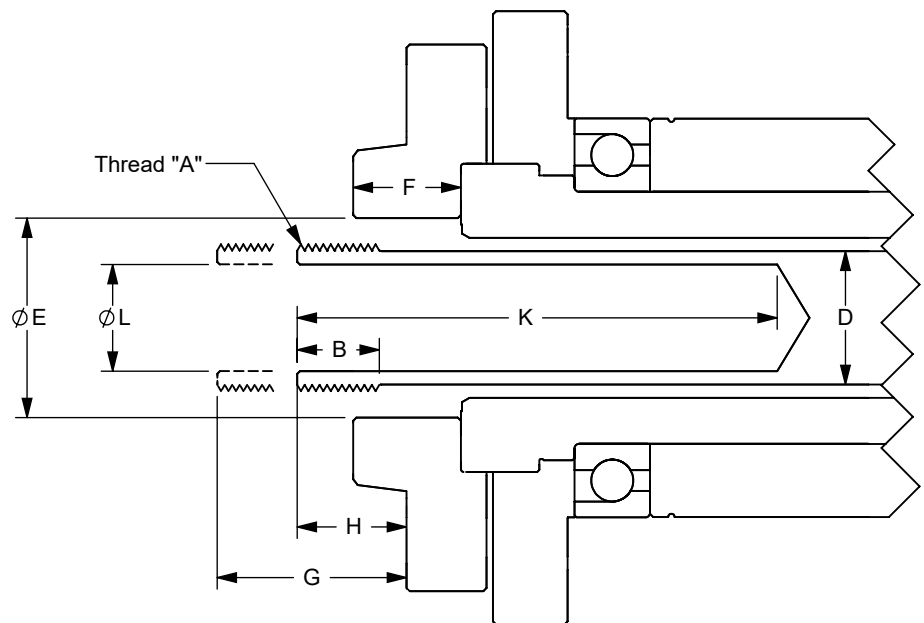
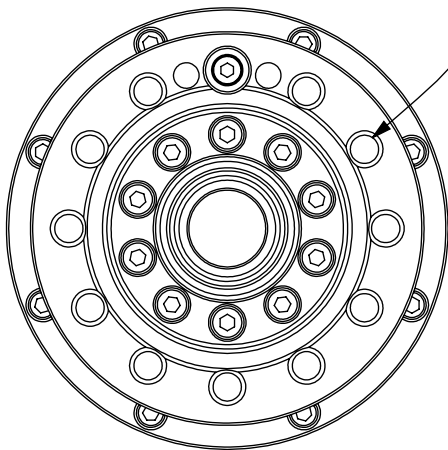

The following dimensions should be used as a reference only. Haas uses many different vendors for our drawtube assemblies. If any custom workholding is required Haas recommends you retrieve the exact dimensions from your delivered machine.

SUB-SPDL-A2-5 for ST-10 to ST-25			
DESCRIPTION	DIMENSION	SAE	METRIC
MAIN OR SUB SPINDLE & TYPE		Sub-Spindle / A2-5	
DIAMETER OF THREAD	A	1.378"	35 MM* or 40 MM
THREAD PITCH	A	0.059"	1.5 MM
INTERNAL OR EXTERNAL	A	External	
LENGTH OF THREAD	B	0.50"	12.7 MM
DRAWTUBE INNER DIAMETER	C	N/A - SOLID DRAWBAR	
DRAWTUBE OUTER DIAMETER	D	1.25"	31.75MM
COUNTERBORE INNER DIAMETER	E	1.870"	47.5 MM
COUNTERBORE DEPTH	F	1.01"	25.65MM
EXTENDED DISTANCE TO NOSE	G		
RETRACTED DISTANCE TO NOSE	H		
FROM SPINDLE FACE TO BACK OF UNION	I	11.72	297.7MM
FROM SPINDLE FACE TO UNION ADAPTOR	J	16.84	427.7MM
EJECTOR POCKET DEPTH	K	4.5"	114.3MM
EJECTOR POCKET DIAMETER	L	1.0"	25.4MM
*M35 applies to Sub-Spindles made after July 2019 - M40 applies to older vintages			