

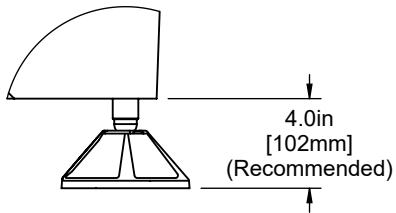

Operating Dimensions

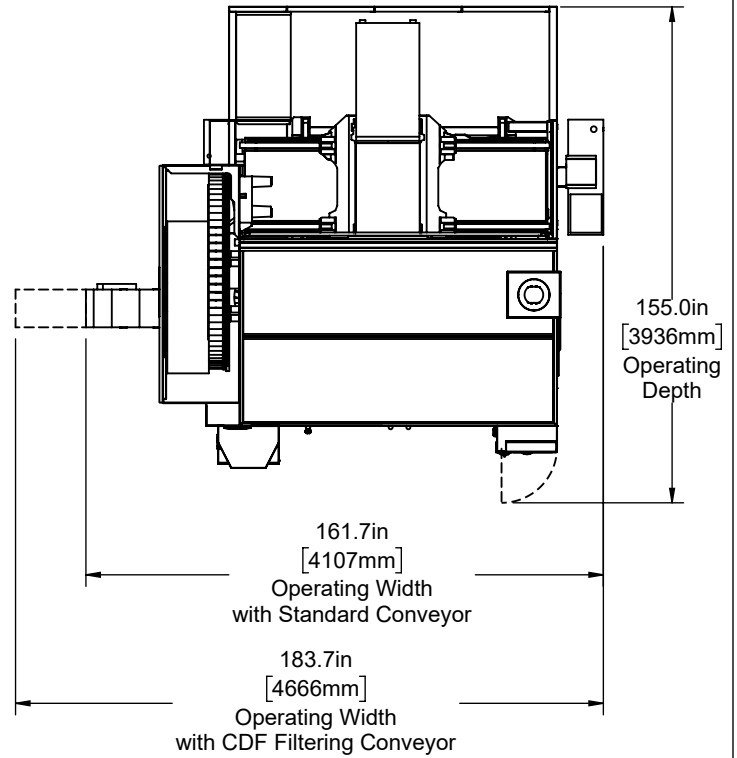

Shipping Dimensions

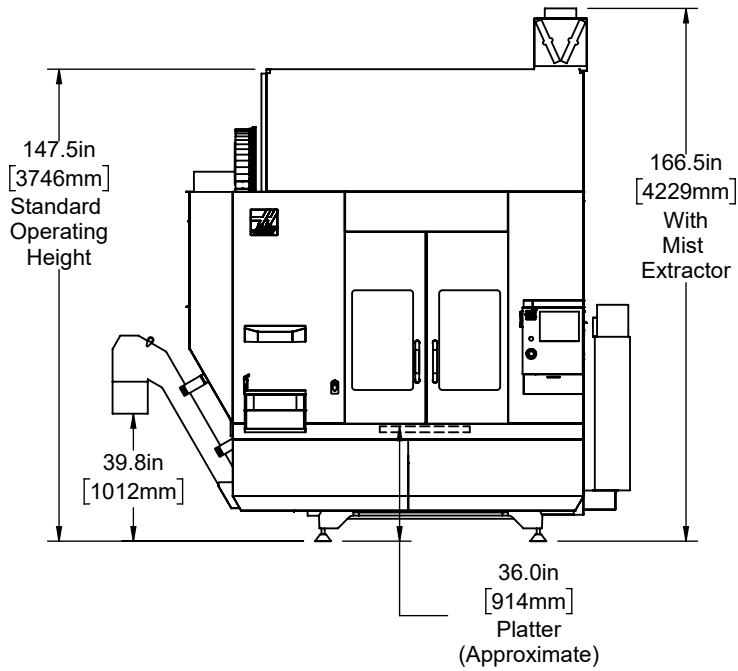
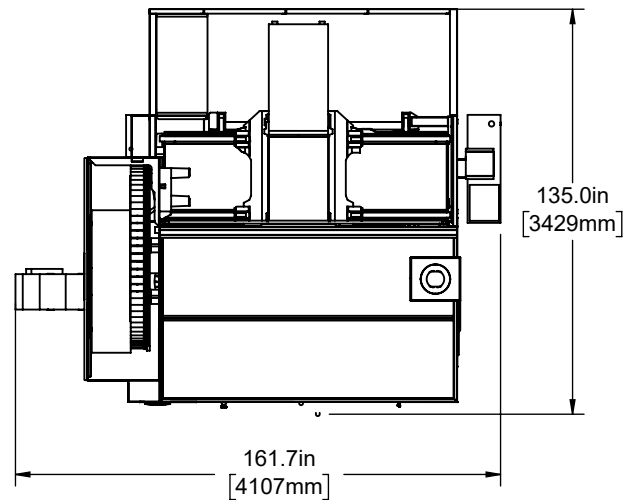
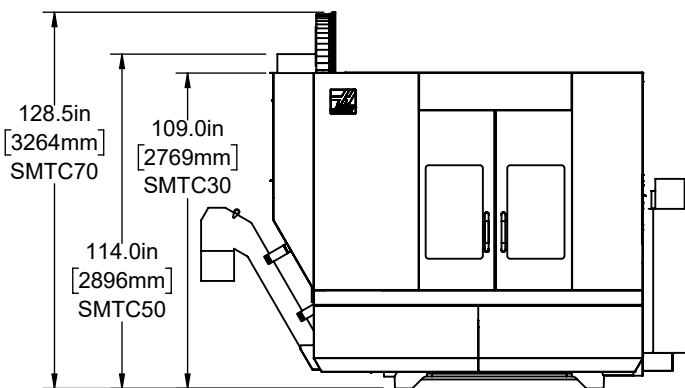



Air & Power

Top View

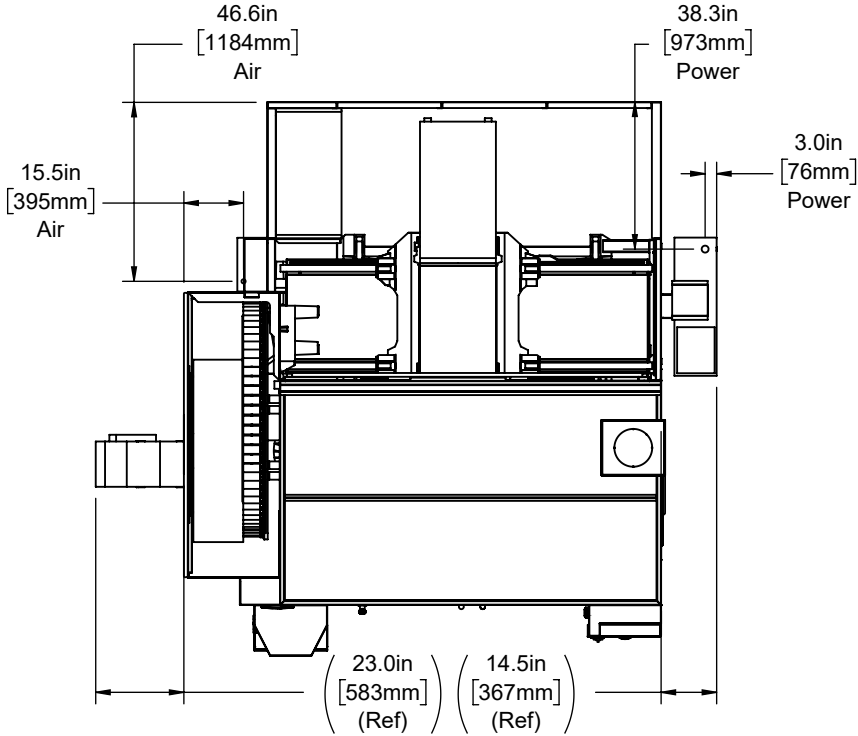

Rear View

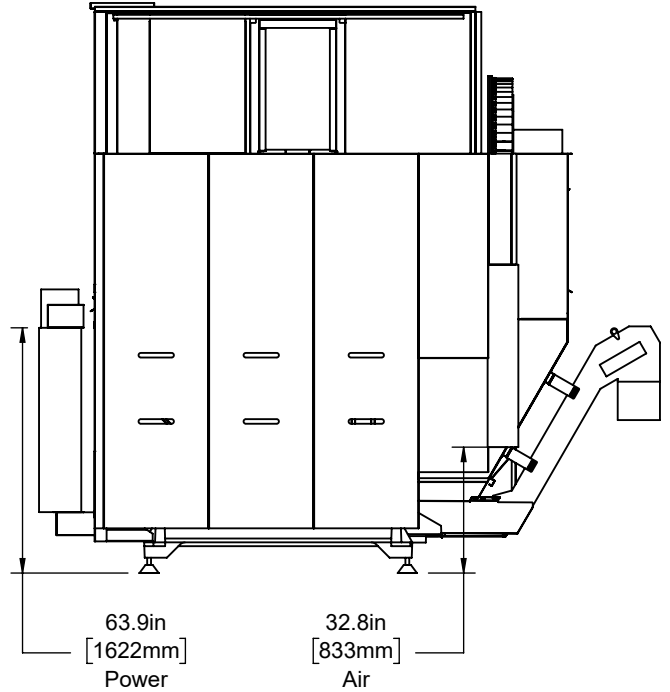

Note - Machine must be placed on one continuous concrete slab. Slab should extend 12in [305mm] beyond anchor holes in all directions

Anchor Pattern

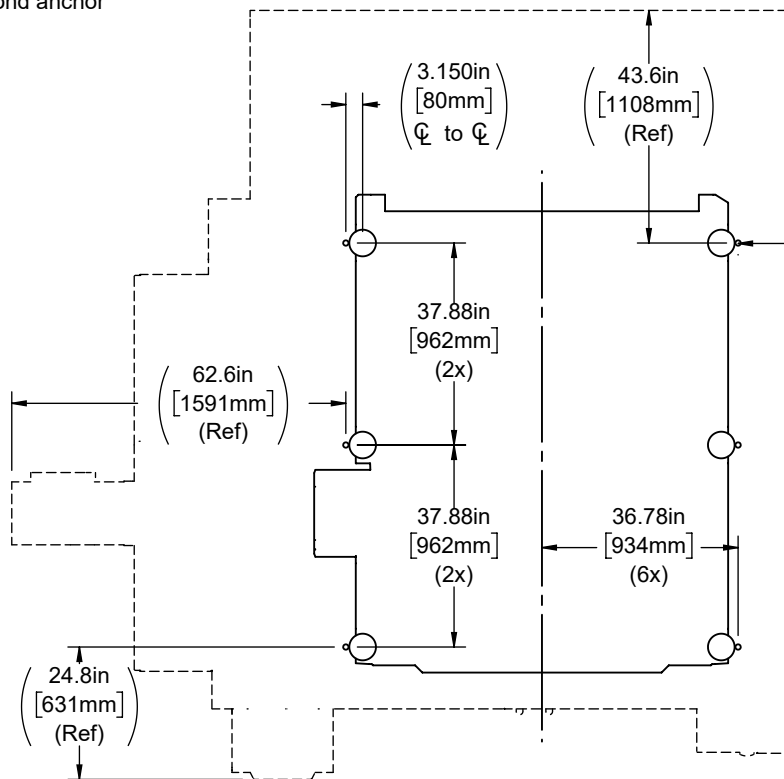

Anchor Hole Detail

Ø.625in [16mm]
▽ 2.0in-2.25in [50.8mm]-[57.2]

25.5in [648mm] (Ref)

Height Breakdown

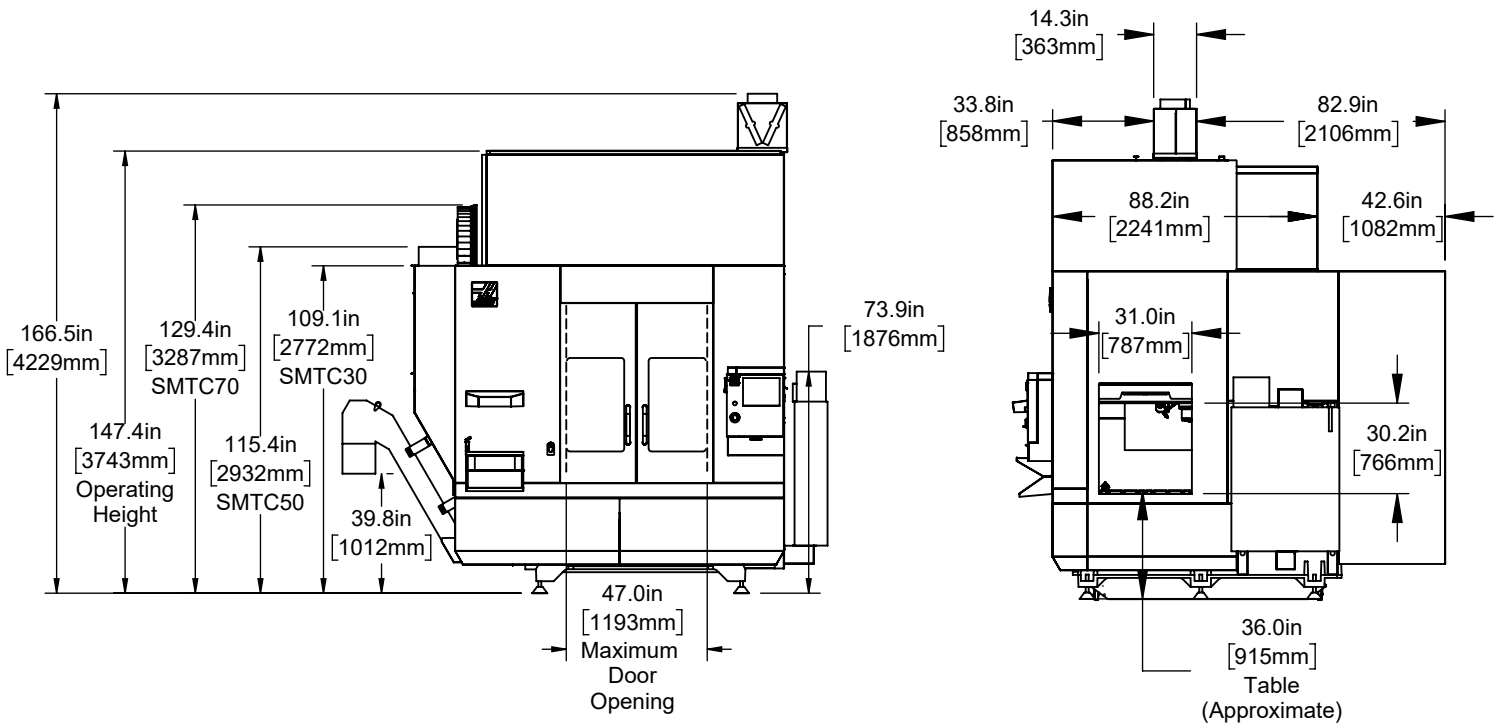

Width Breakdown

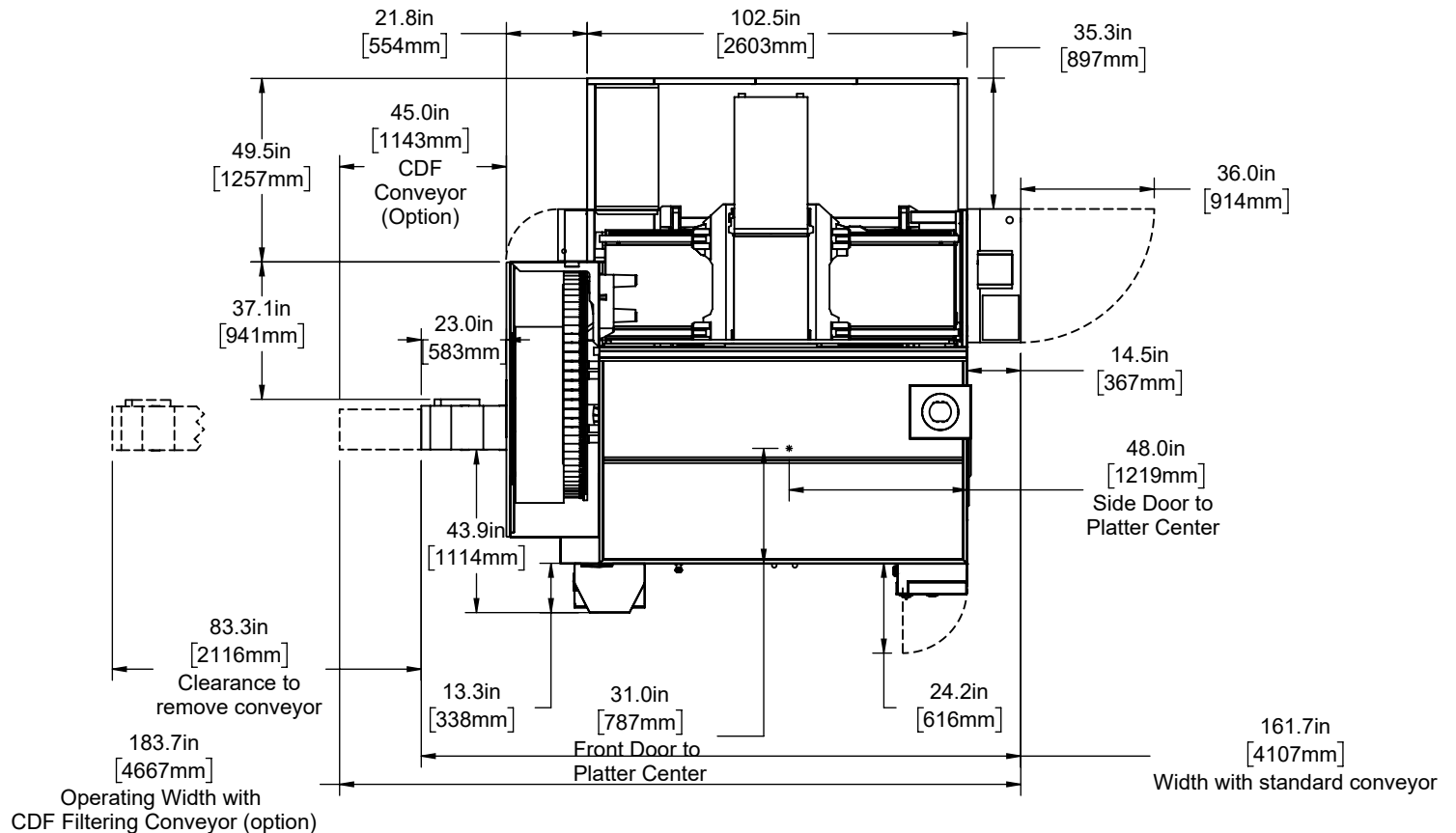



Standard Table

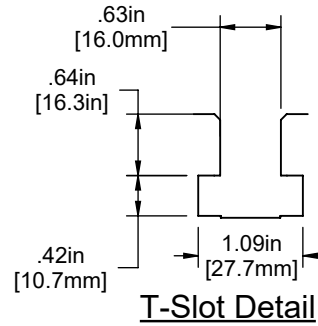
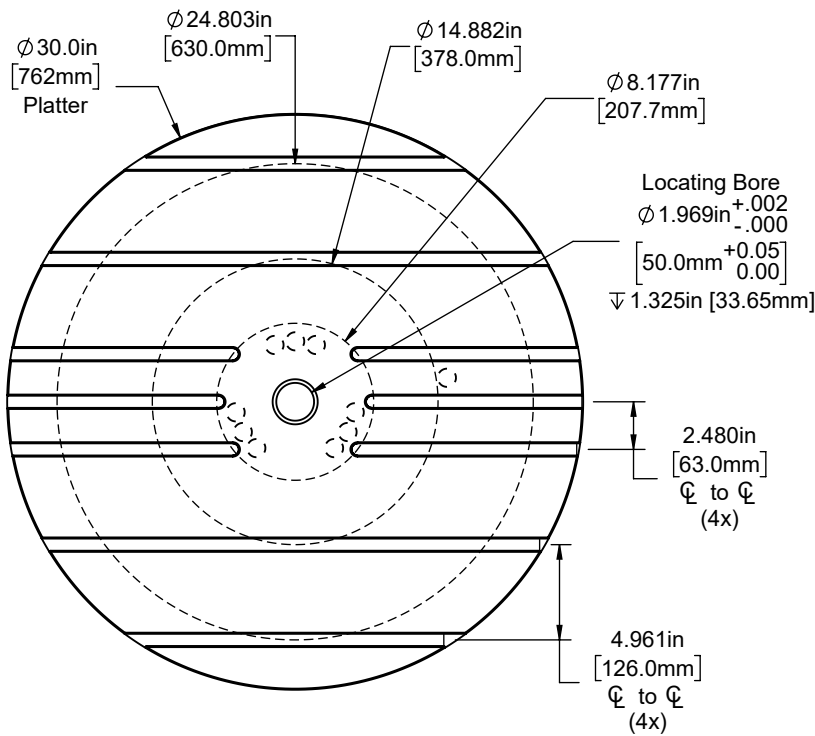

Blank Platter Option

Drill and tap custom fixturing holes as needed
 ▽ 1.500in [38.1mm] maximum hole depth

Do not use existing holes

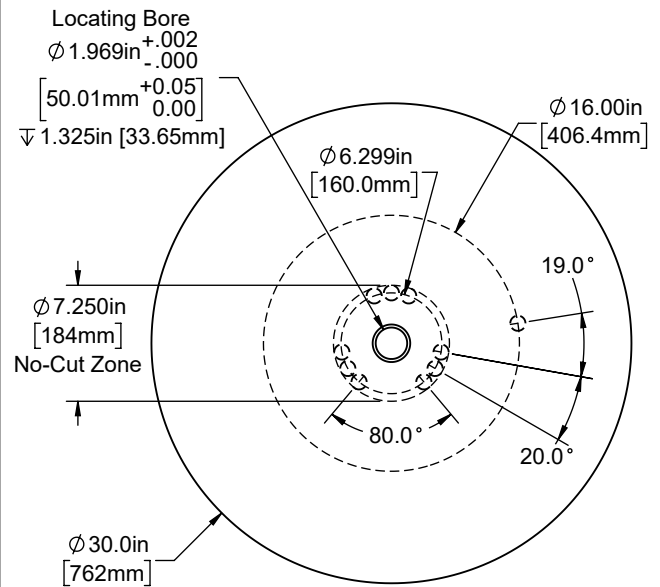

Note

- (10x) Phantom holes cannot be used for part fixturing

Tool Changer

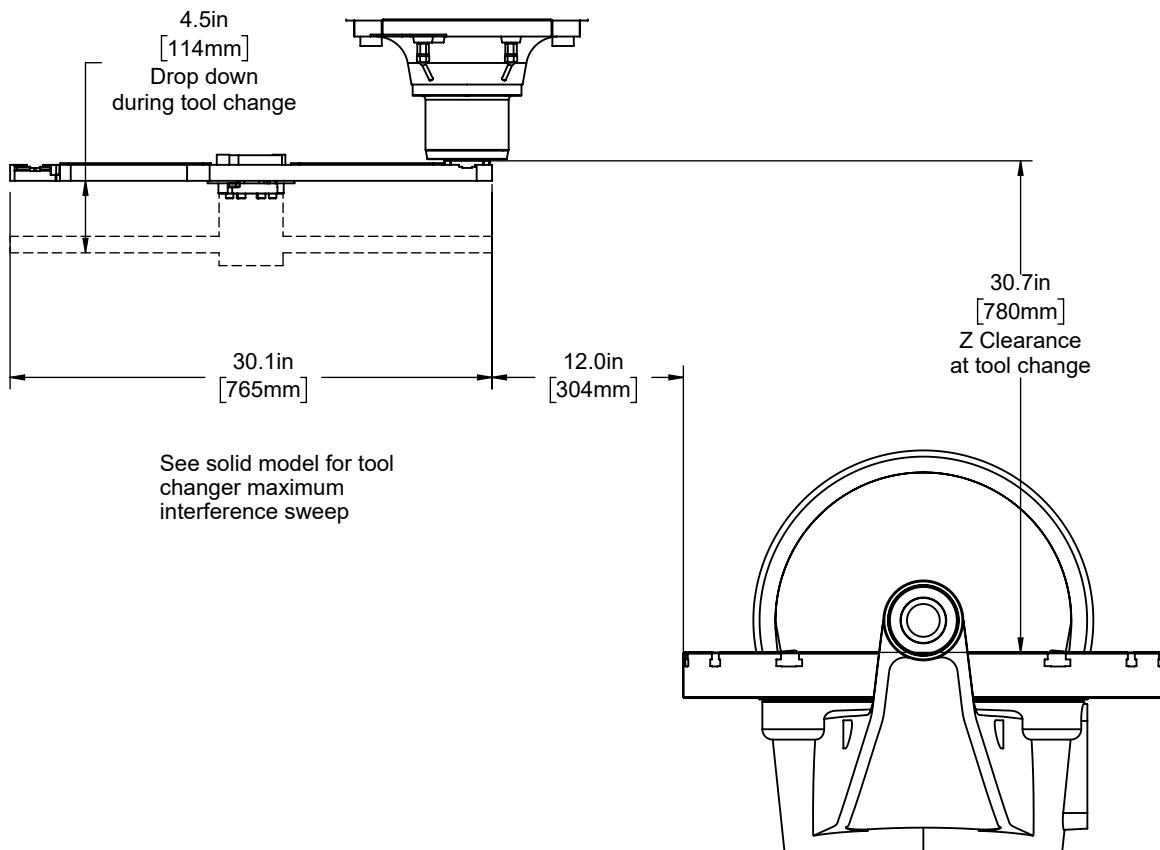



X&Y-Axis Clearance

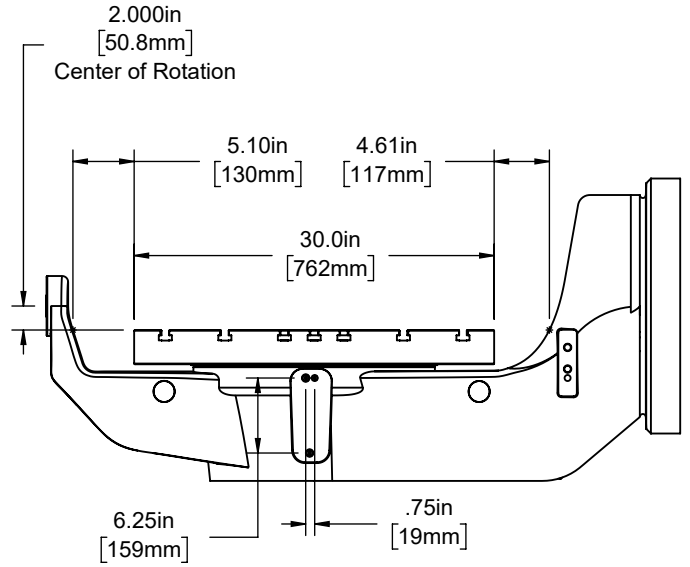
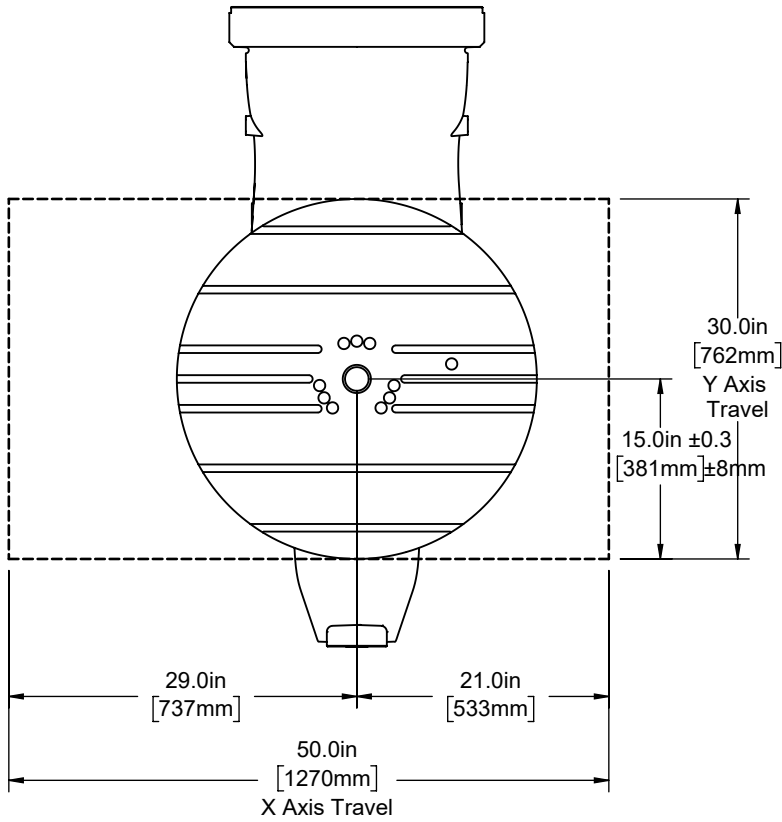

Z-Axis Clearance

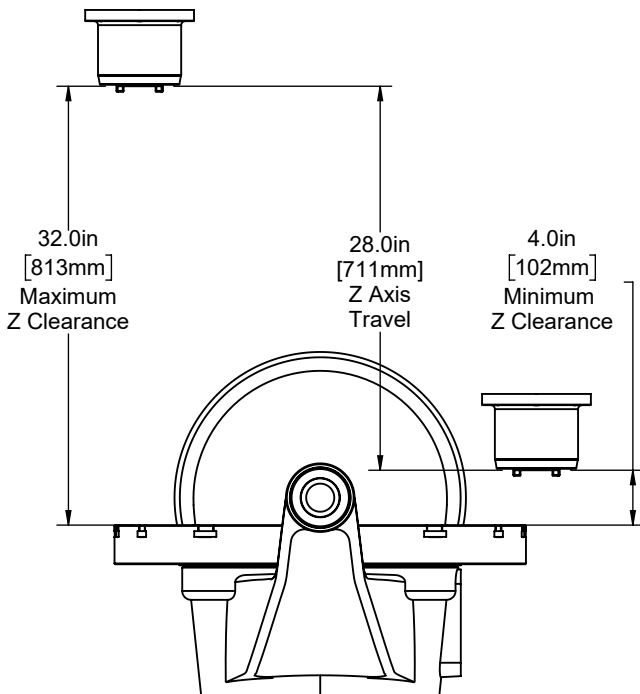
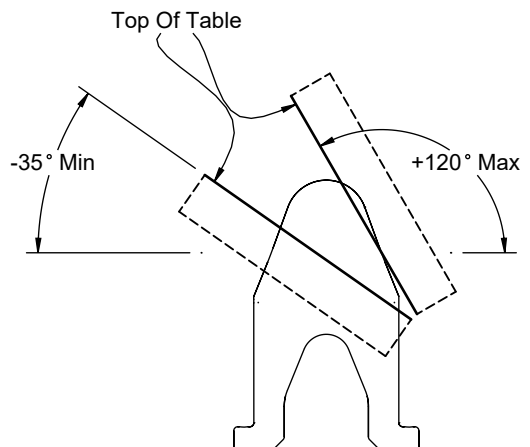
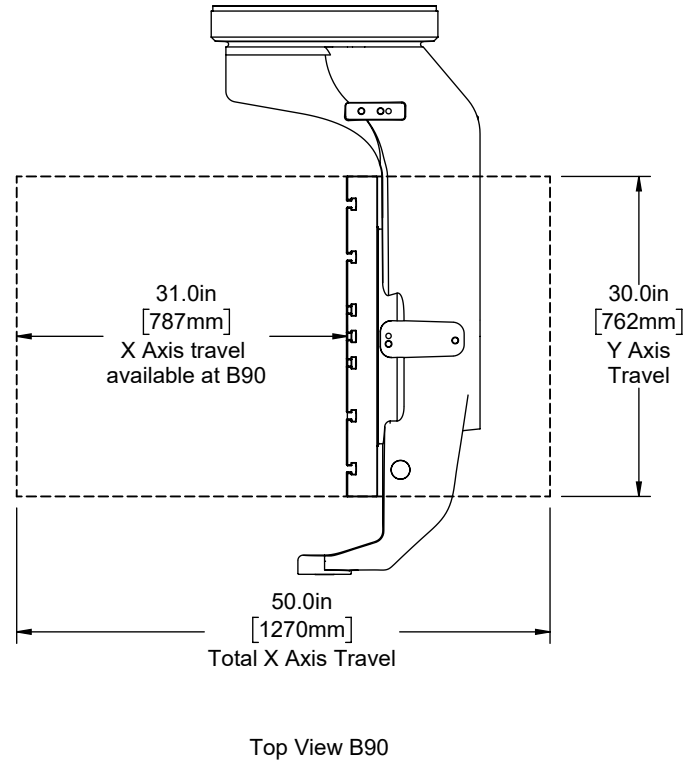
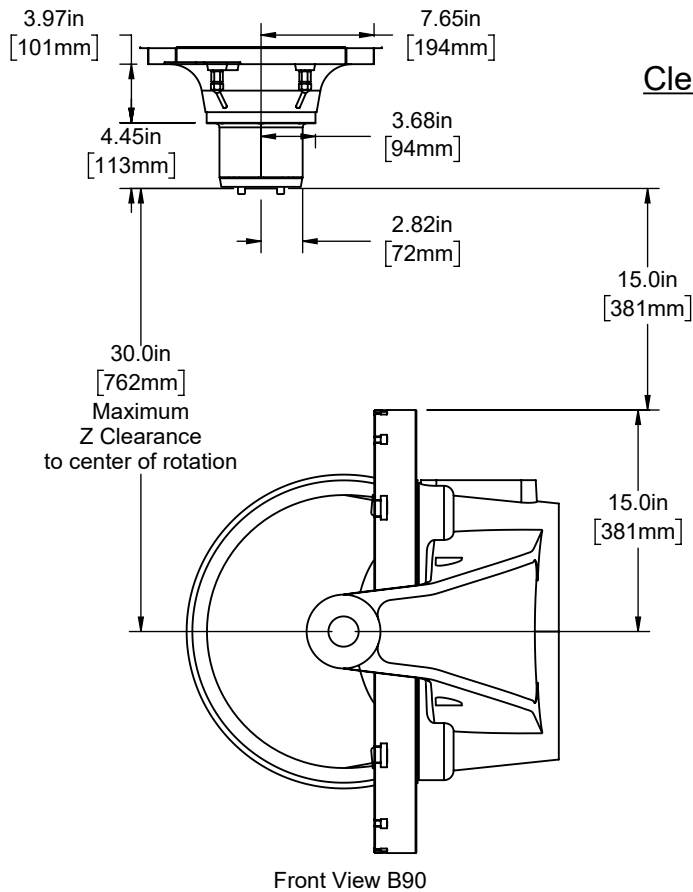

Table Rotation





Work Envelope

Isometric reference only - not drawn to scale

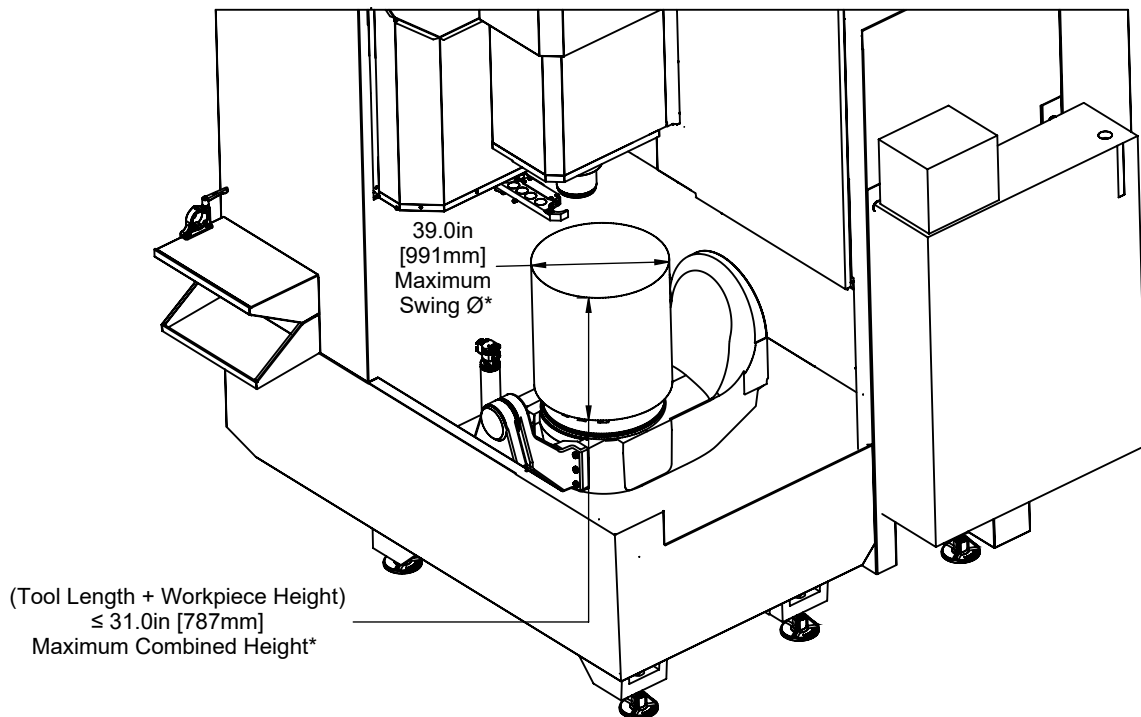

***Note** - Maximum height and swing apply to B0 orientation only. Large workpieces, including ones within the stated work envelope, may interfere with other machine components as the tilt angle increases. If your part is larger than 30.0in [762mm] diameter or taller than 25in [635mm] it is recommended to review your application's suitability with your local HFO Applications team